

## ENGINE COMPARTMENT

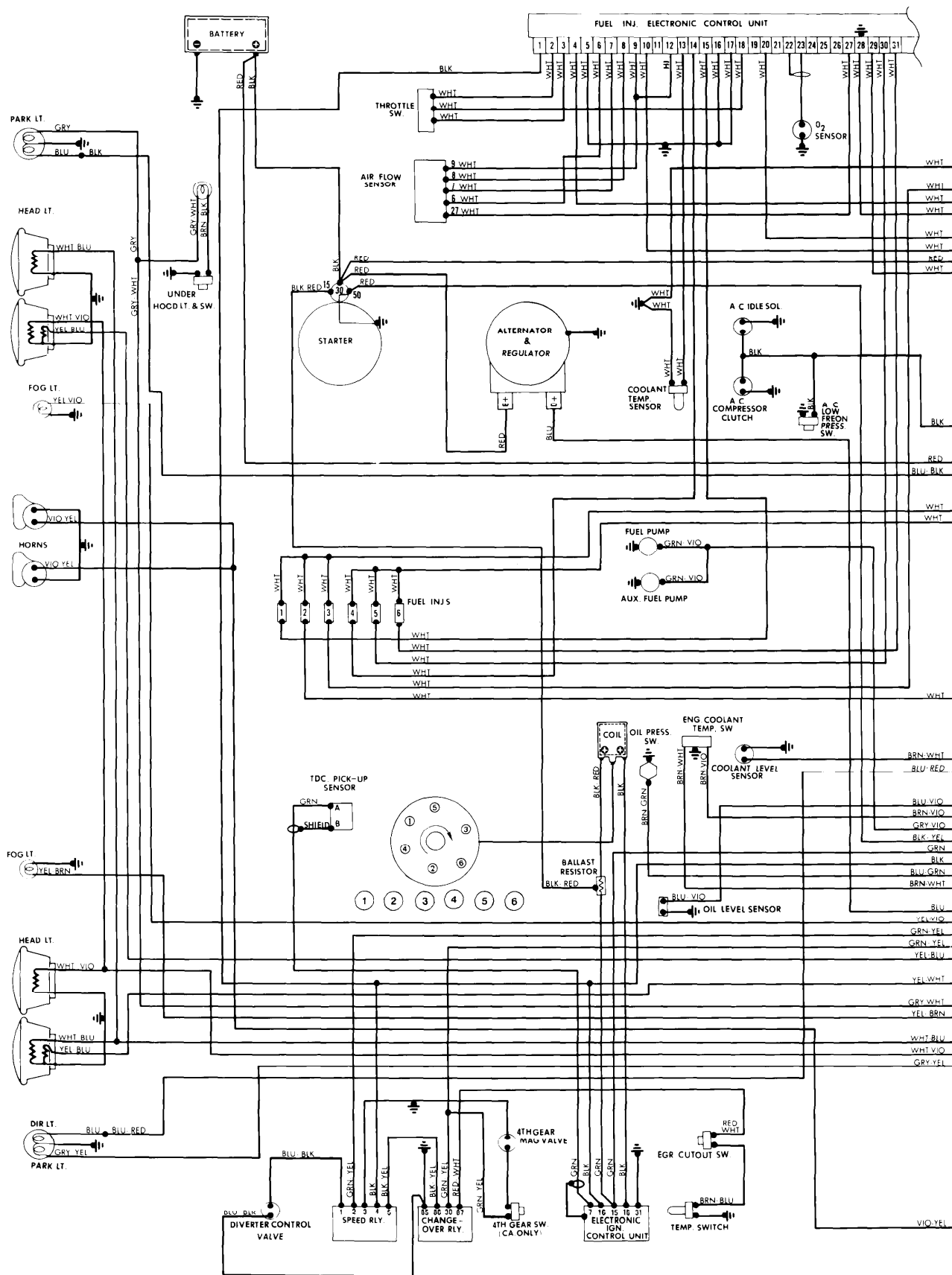

## FUSE BLOCK

WIRING DIAGRAMS

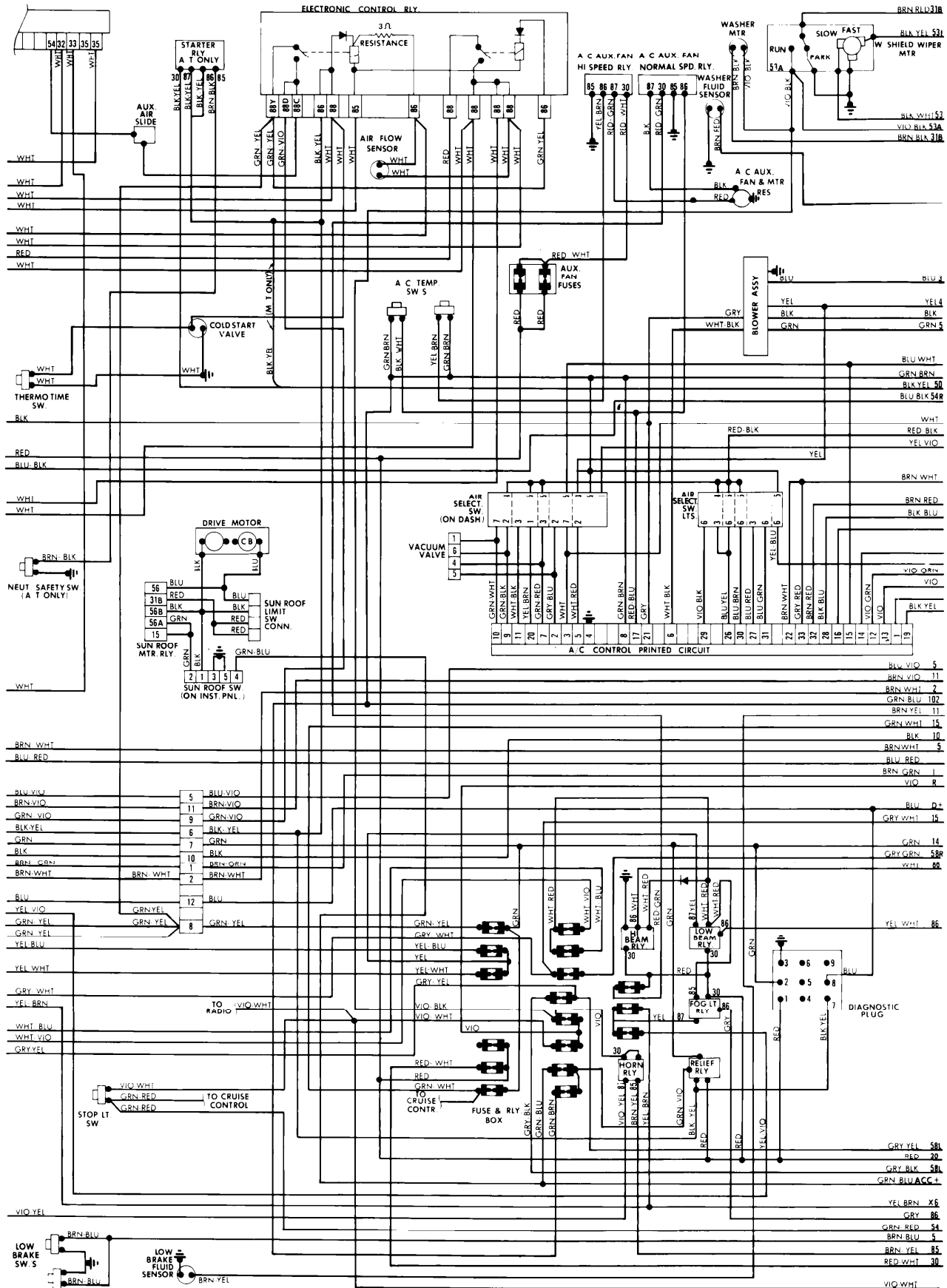

## INSTRUMENT PANEL

