

# 1982 General Motors BLAZER, JIMMY, PICKUPS & SUBURBANS

## ENGINE COMPARTMENT

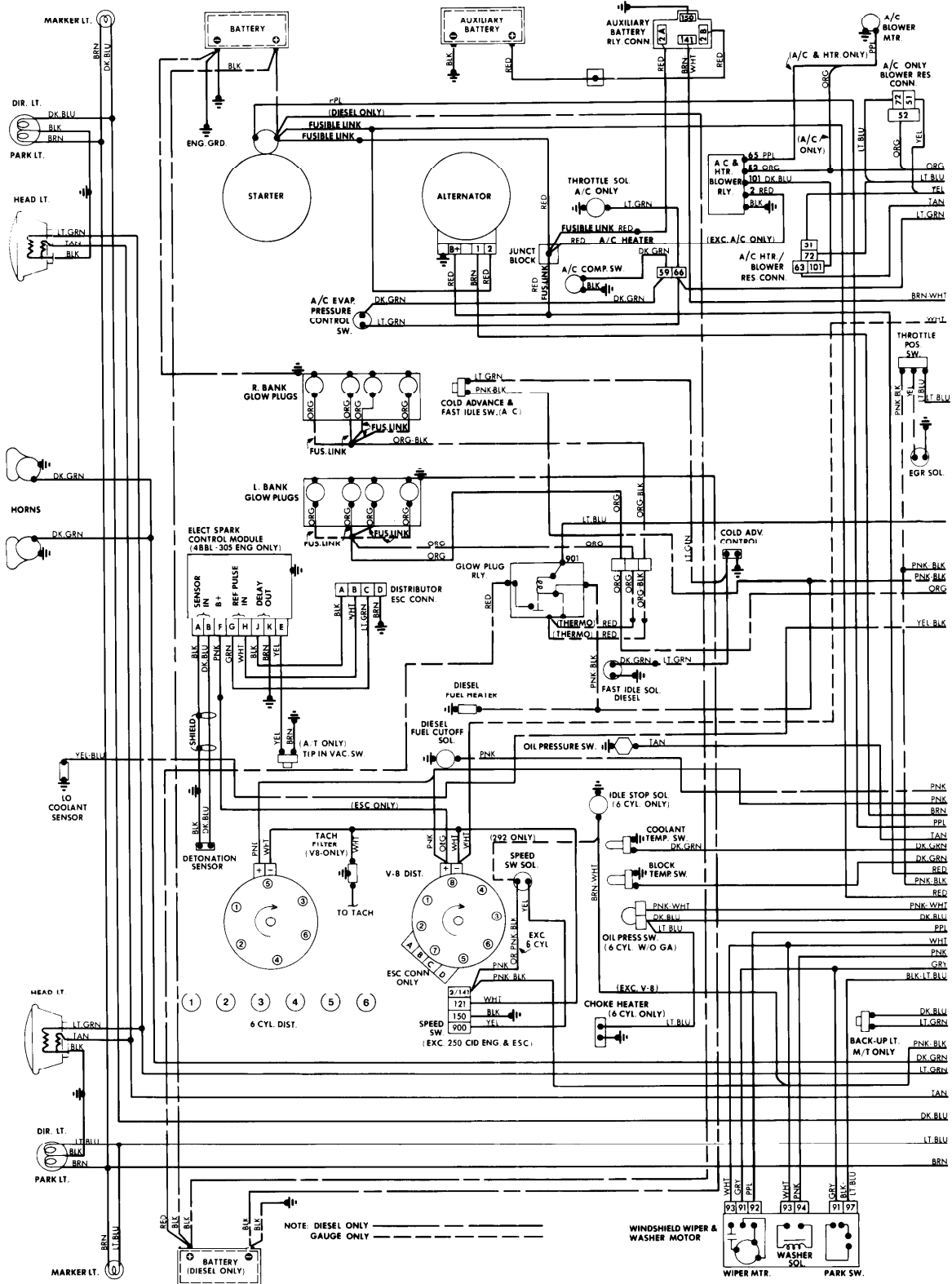

# 1982 General Motors

5-19

## BLAZER, JIMMY, PICKUPS & SUBURBANS (Cont.)

### ENGINE COMPARTMENT, FUSE BLOCK & UNDERDASH

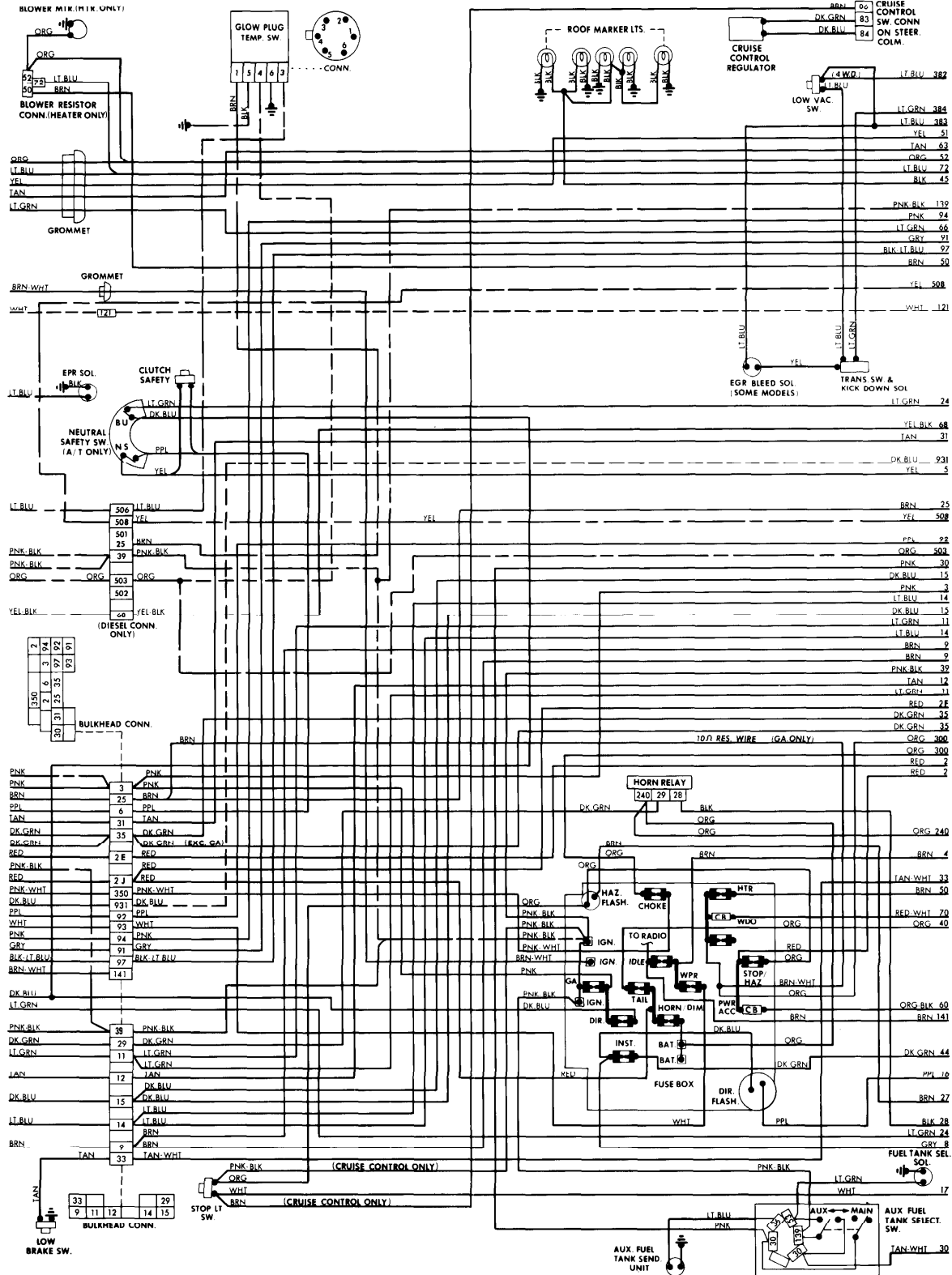



# 1982 General Motors

## BLAZER, JIMMY, PICKUPS & SUBURBANS Cont.)

### REAR LIGHTING & ACCESSORIES

