

ENGINE COMPARTMENT

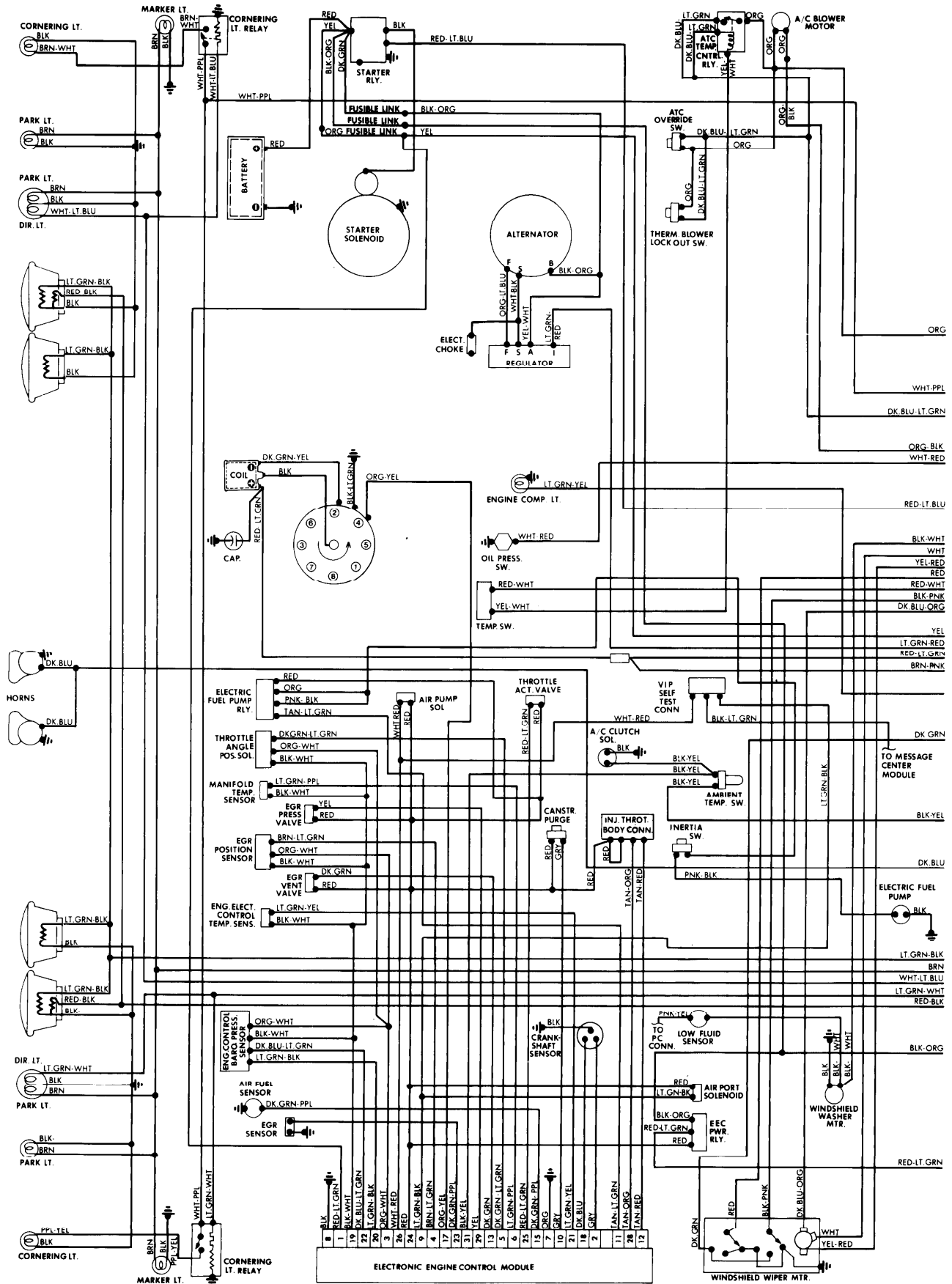

FUSE BLOCK & UNDERDASH

WIRING DIAGRAMS

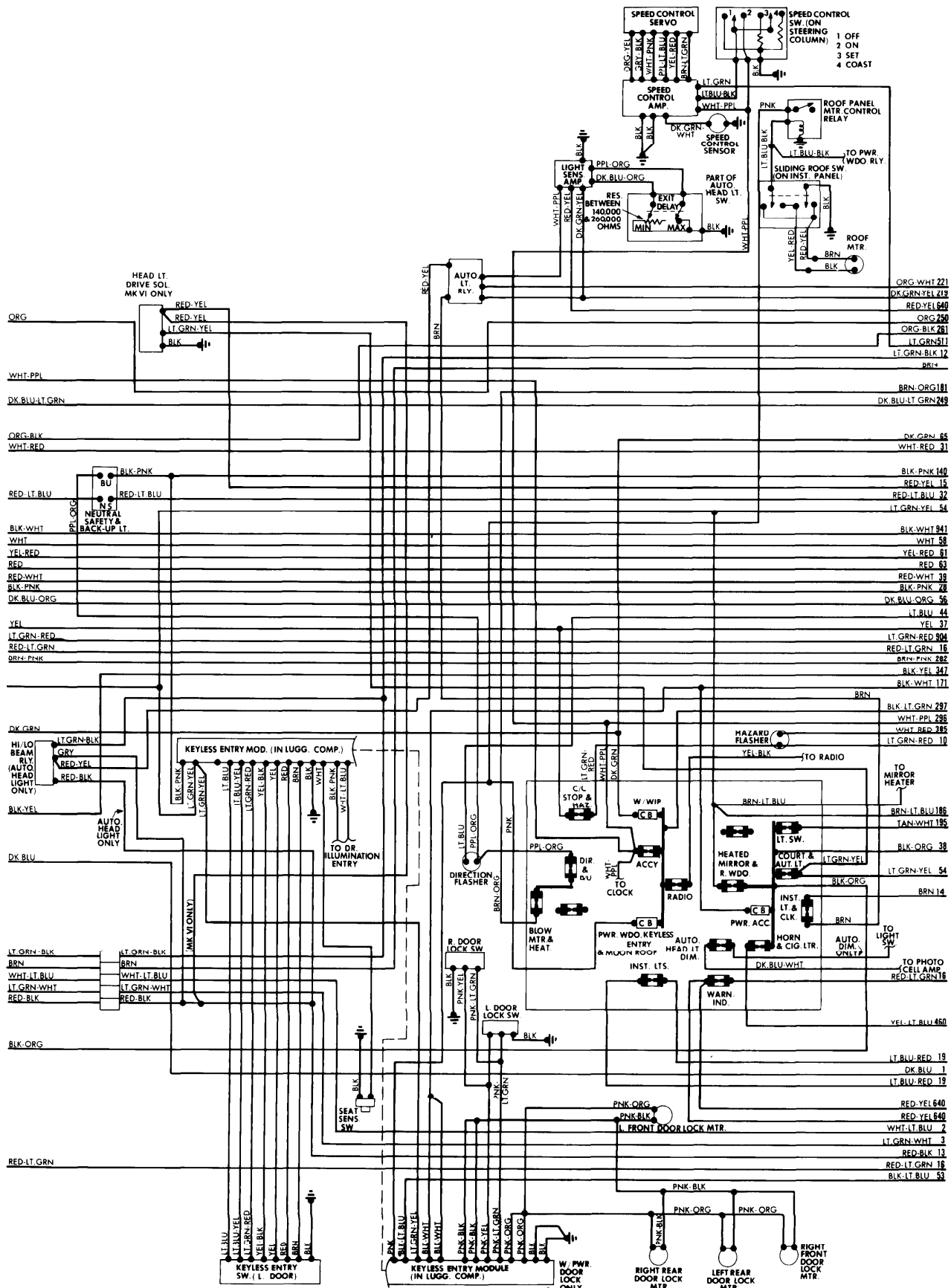

INSTRUMENT PANEL & UNDERDASH

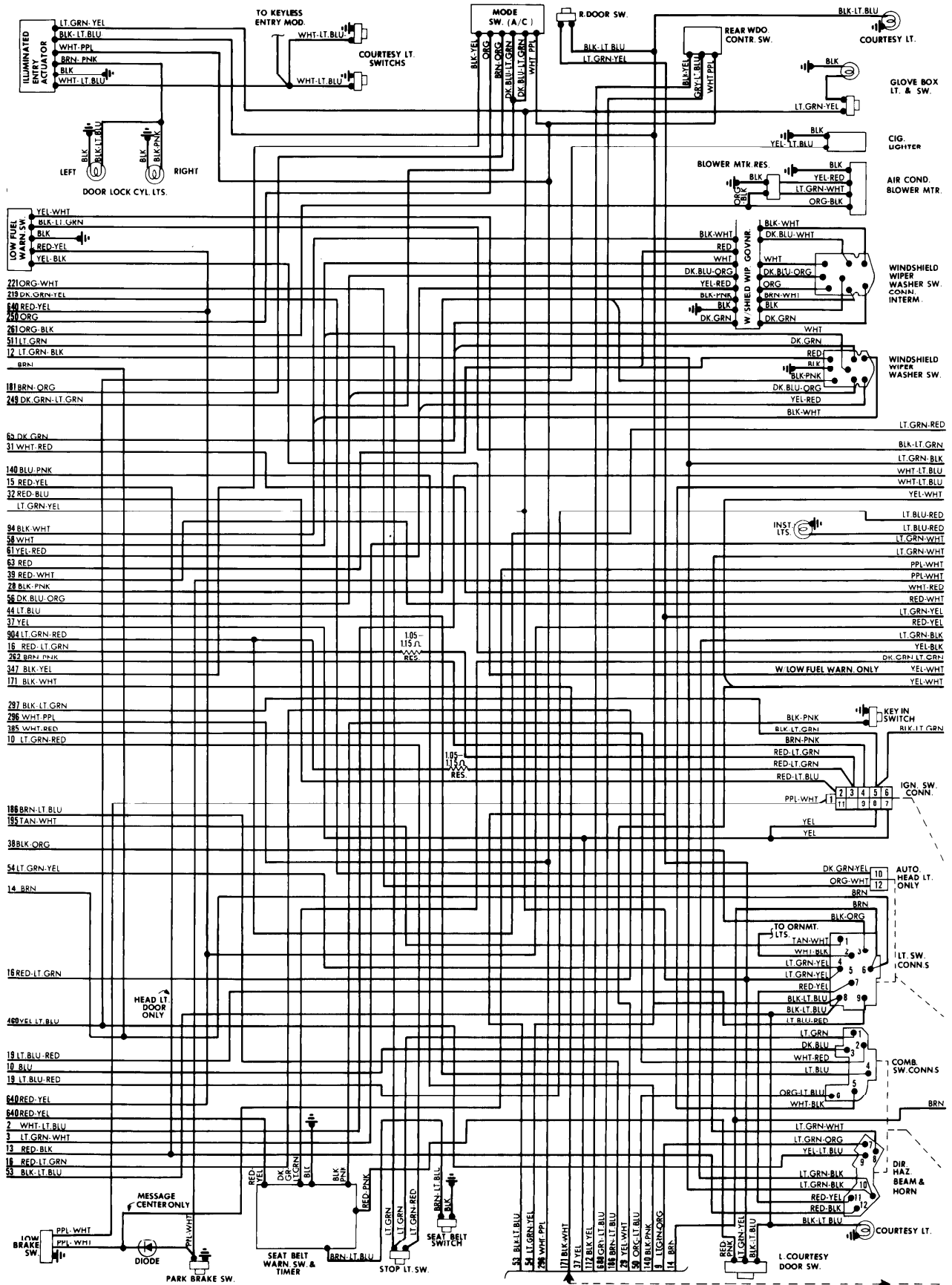

INSTRUMENT PANEL & ACCESSORIES

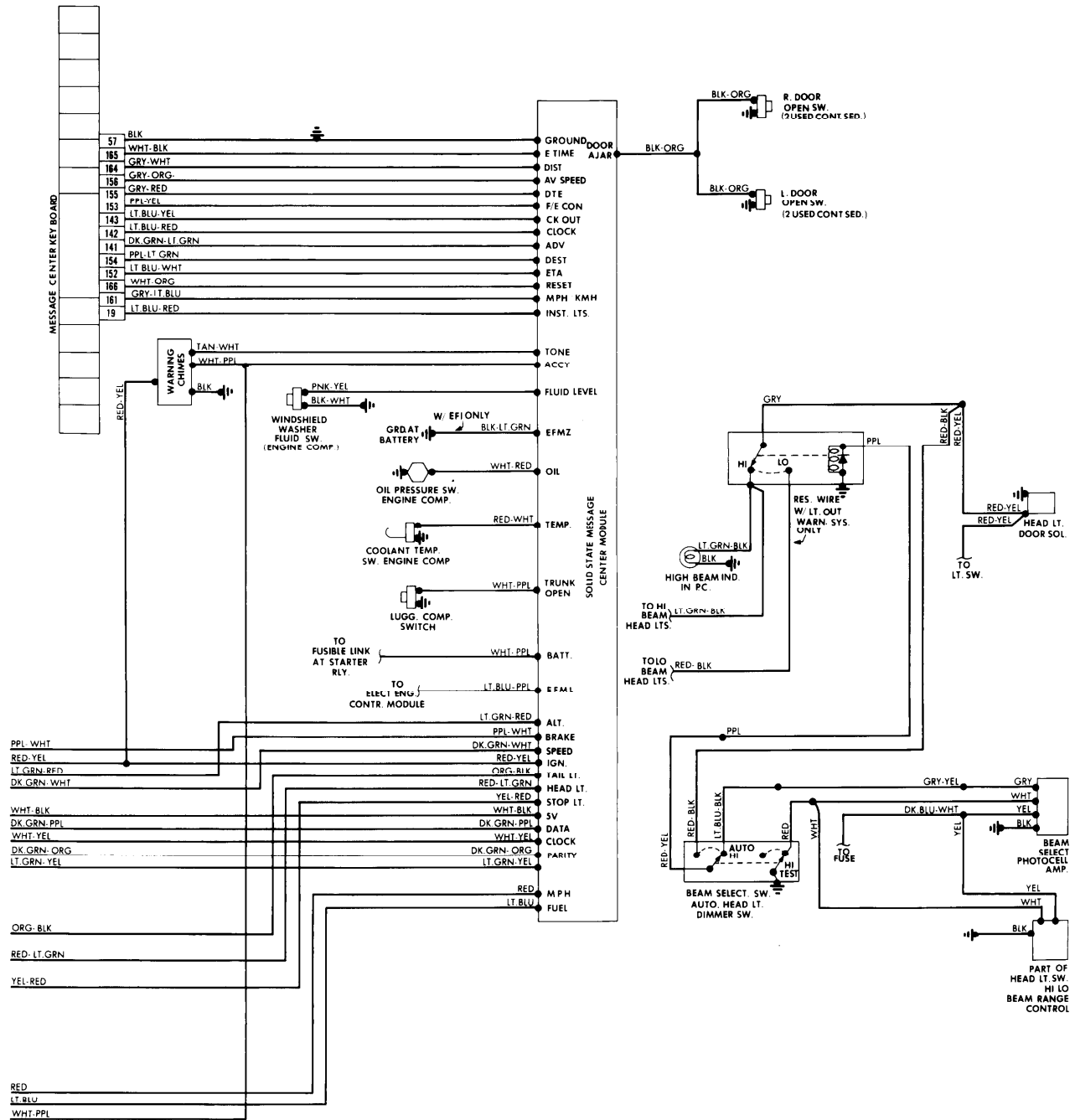

REAR COMPARTMENT & ACCESSORIES (Cont.)

WIRING DIAGRAMS

