

1980 Spark Timing Systems - Electric 4-137

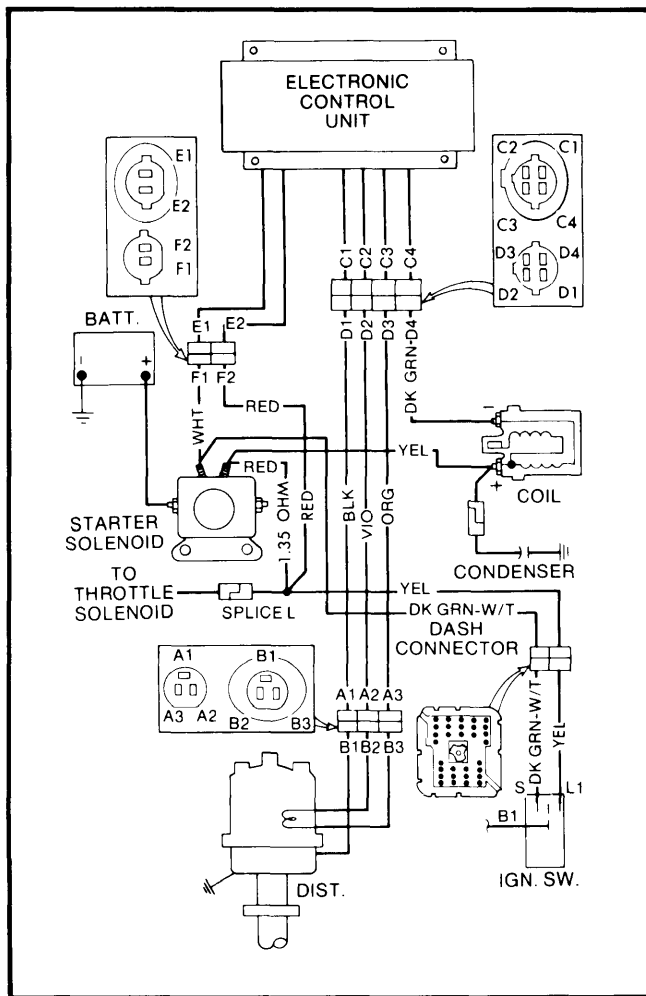

Solid State Ignition System Wiring Diagram for American Motors

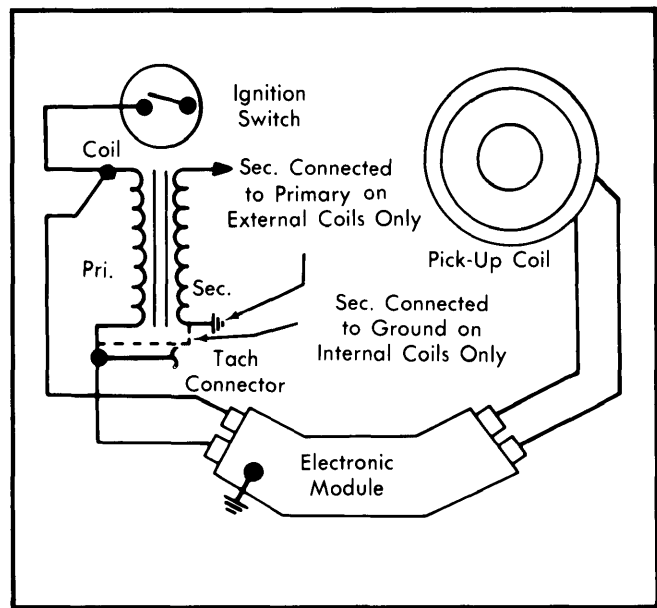

Delco-Remy High Energy Ignition (HEI) System Wiring Diagram for American Motors (4-Cylinder Models Only)

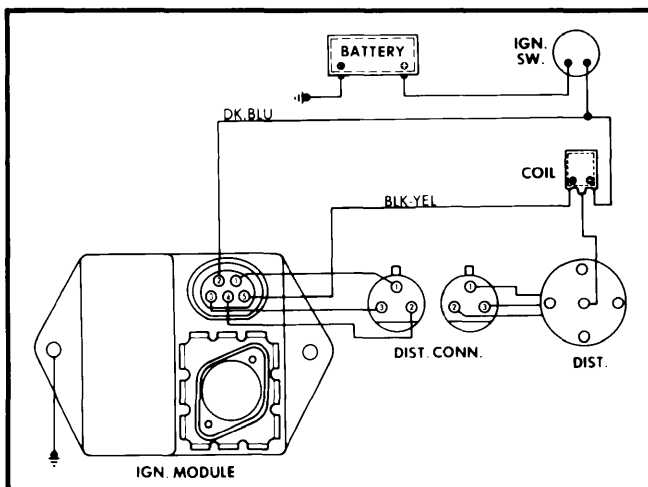

Electronic Ignition Wiring Diagram for Chrysler Corp. (4-Cylinder Models)

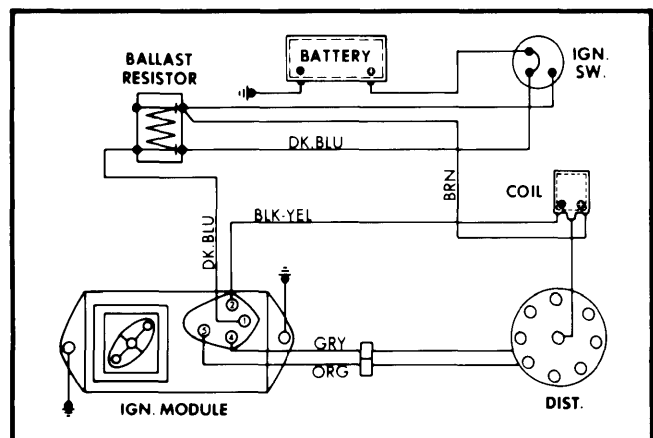

Electronic Ignition Wiring Diagram for Chrysler Corp. (6-Cylinder & V8 Models)

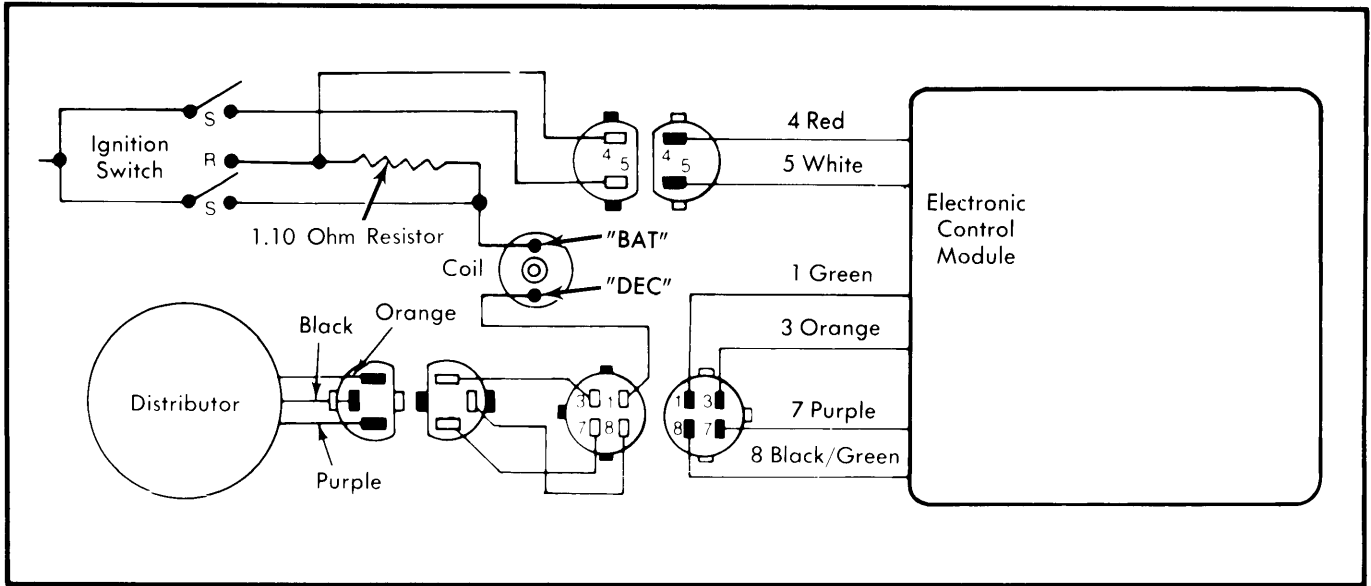

Dura-Spark II Ignition System Wiring Diagram for Ford Motor Co.

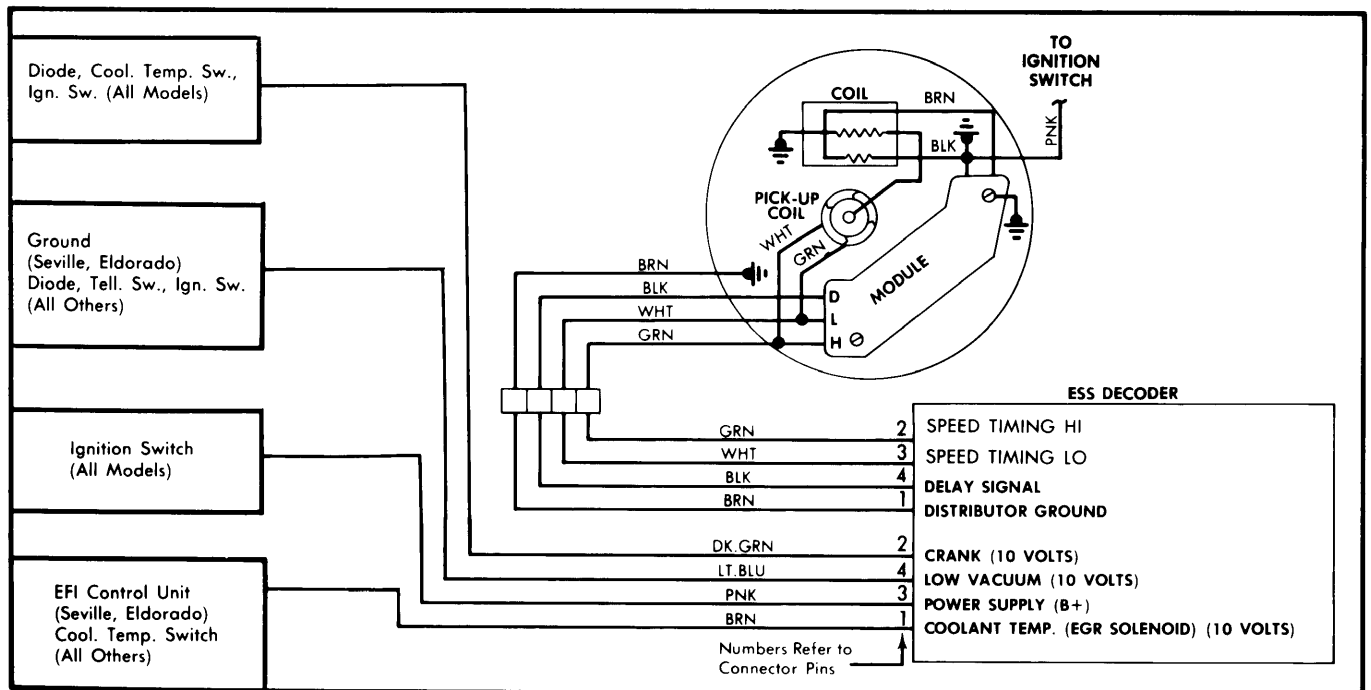

Electronic Spark Selection (ESS) Ignition System Wiring Diagram for General Motors

4-140 1980 Spark Timing Systems - Electric

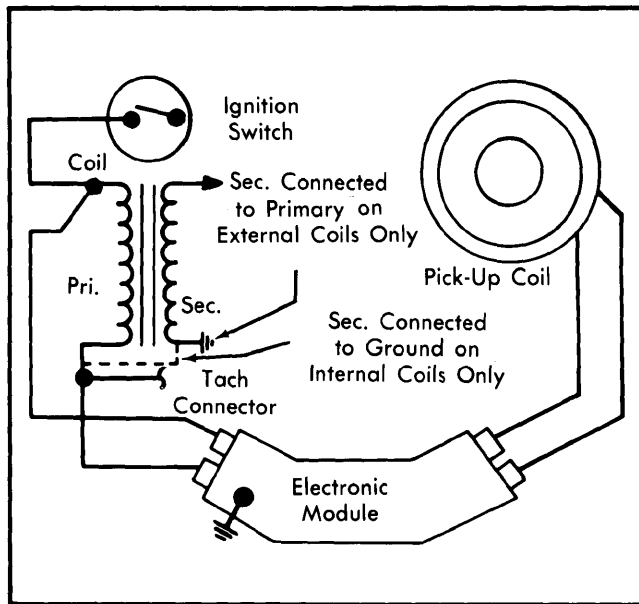

**Delco-Remy High Energy Ignition (HEI) System
Wiring Diagram for General Motors**

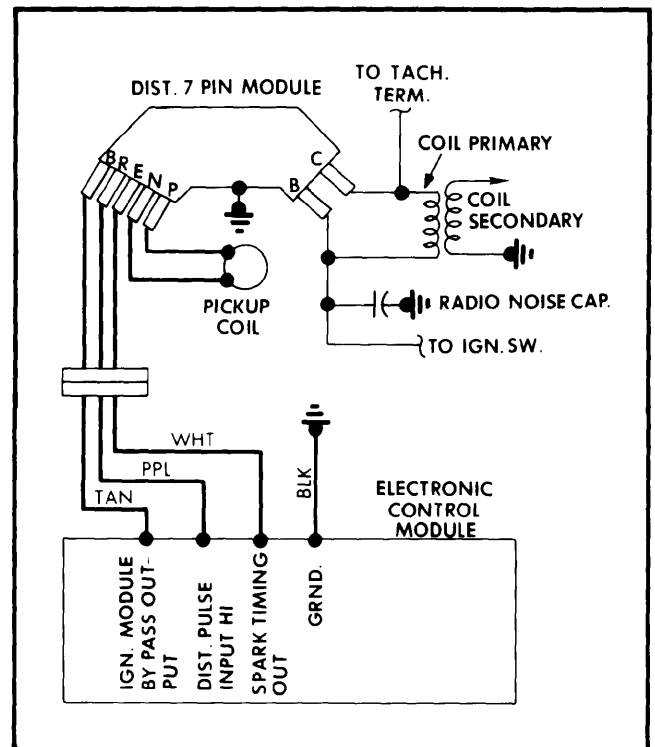

**Electronic Spark Timing (EST) Ignition System
Wiring Diagram for General Motors**

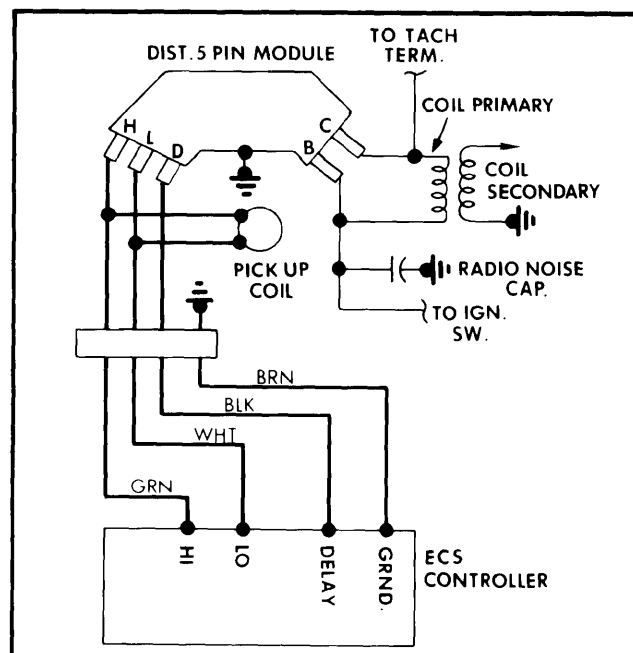

**Electronic Spark Control (ESC) Ignition System
Wiring Diagram for General Motors
(Without Turbocharger)**

1980 Spark Timing Systems - Electric 4-141

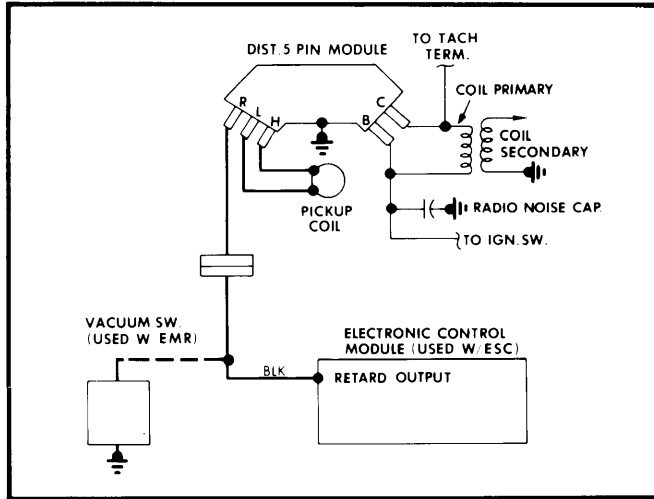

Electronic Module Retard (EMR) Ignition System Wiring Diagram for General Motors

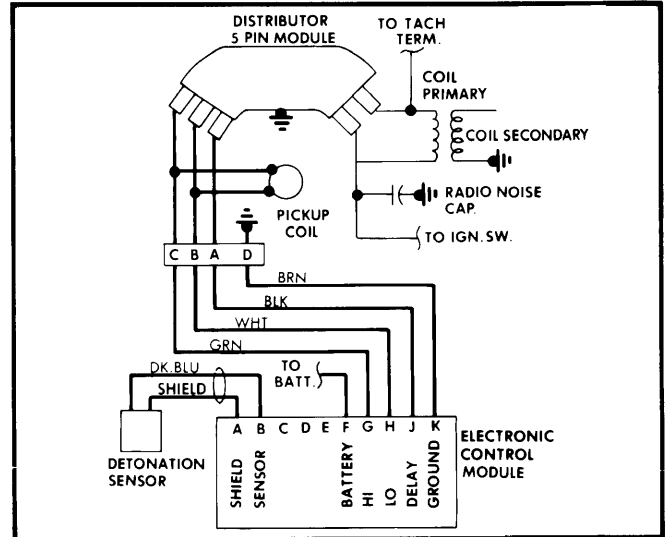

Electronic Spark Control (ESC) with Turbocharger Ignition System Wiring Diagram for General Motors

1980 Speed Controls - Electric

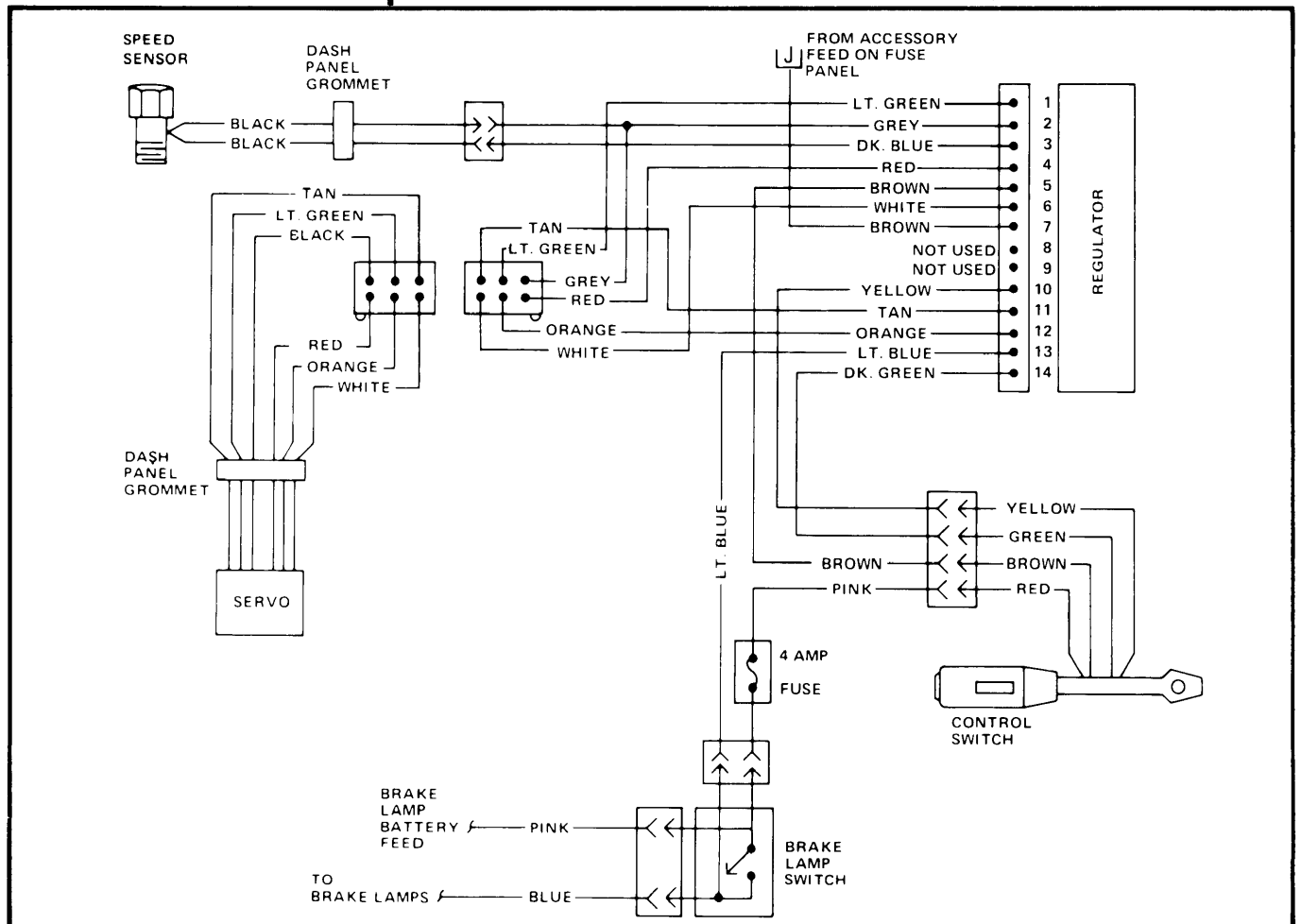

Cruise Command Wiring Diagram for American Motors