

# 1976 Power Seat Controls

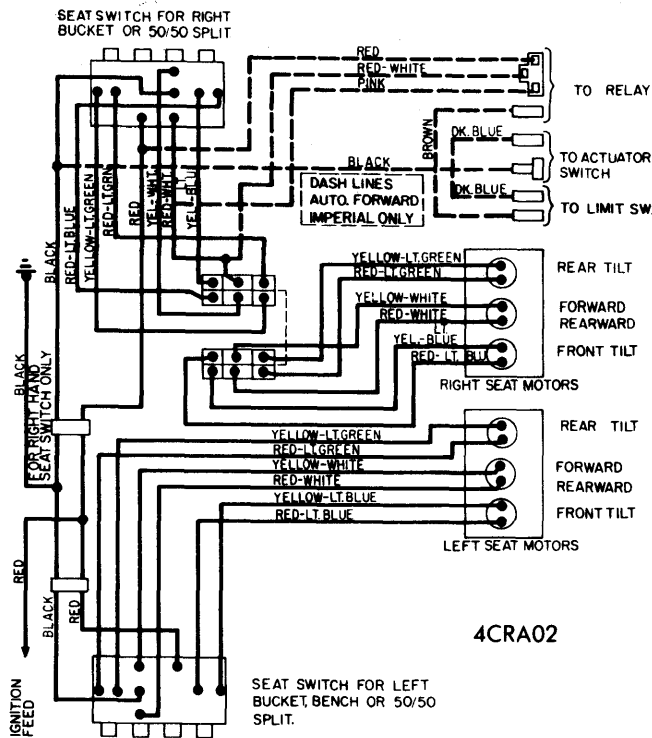

CHRYSLER CORP. POWER SEAT WIRING

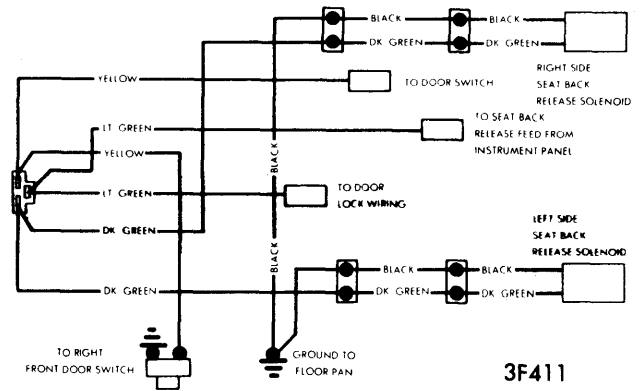

CHRYSLER CORP. SEAT BACK LATCH WIRING

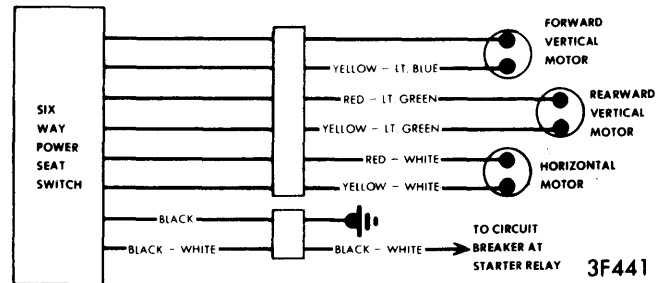

FORD MOTOR CO. SIX-WAY POWER SEAT WIRING (BENCH SEAT)

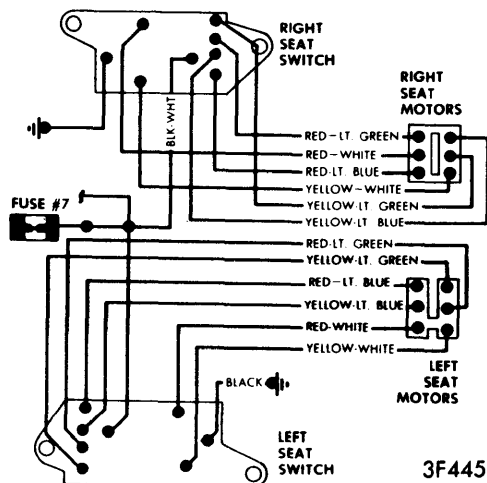

FORD MOTOR CO. SIX-WAY POWER SEAT WIRING (SPLIT BENCH)

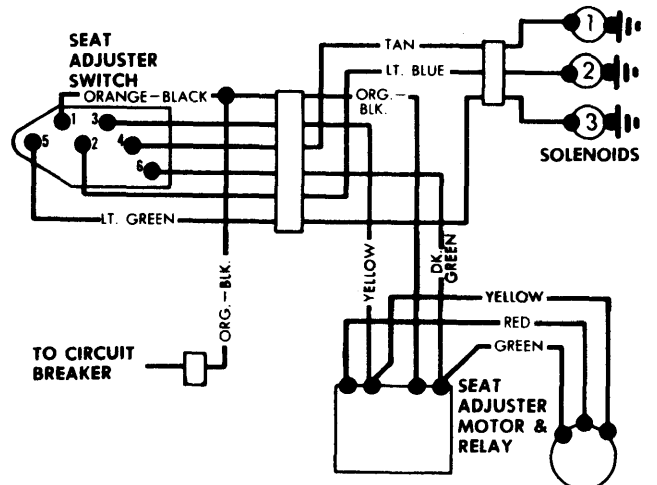

GENERAL MOTORS 4-WAY & 6-WAY POWER SEAT WIRING

# 1976 Power Seat Controls

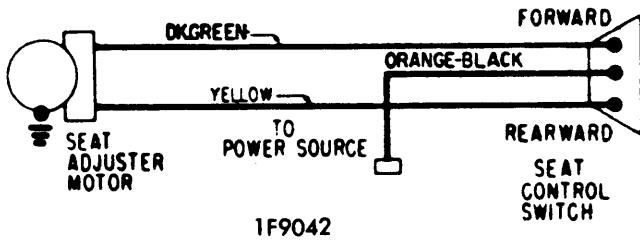

GENERAL MOTORS  
TWO-WAY POWER SEAT WIRING

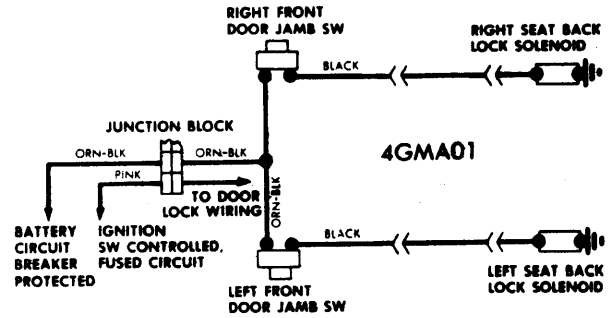

GENERAL MOTORS  
SEAT BACK LATCH WIRING

# 1976 Turn Signal & Hazard Flasher Systems

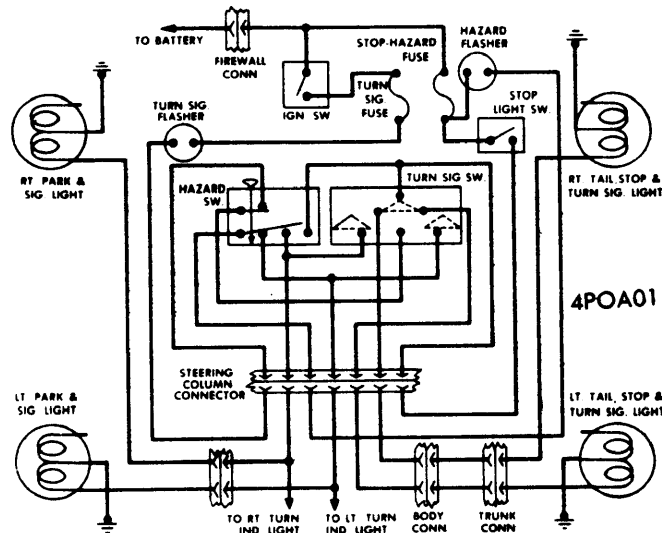

ALL CAR MODELS TURN SIGNAL & HAZARD WARNING  
WIRING (TYPICAL)