

1973 Electric Window Controls

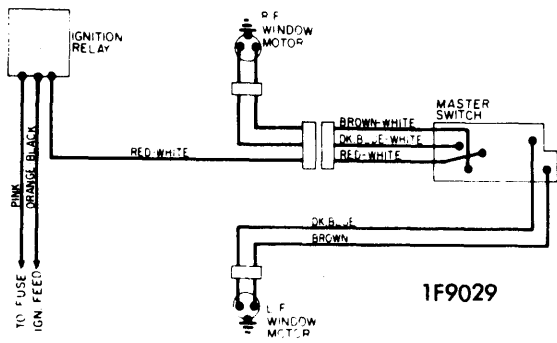

**GENERAL MOTORS "F" STYLE
POWER WINDOW WIRING**

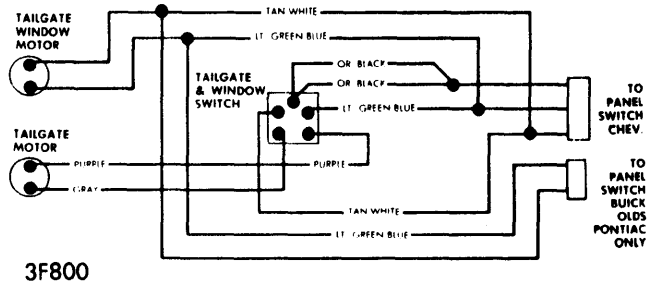

GENERAL MOTORS TAILGATE WINDOW WIRING

1973 Electric Windshield Wipers

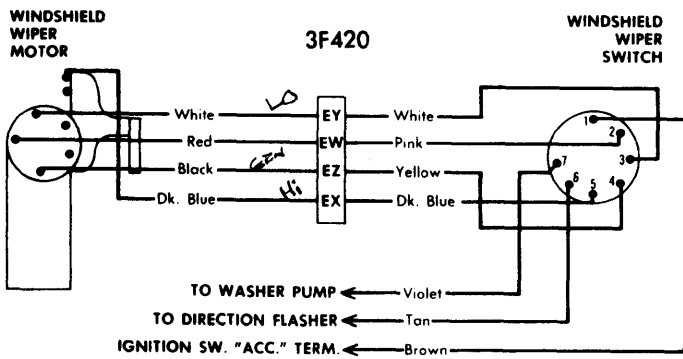

AMERICAN MOTORS WIPER SYSTEM

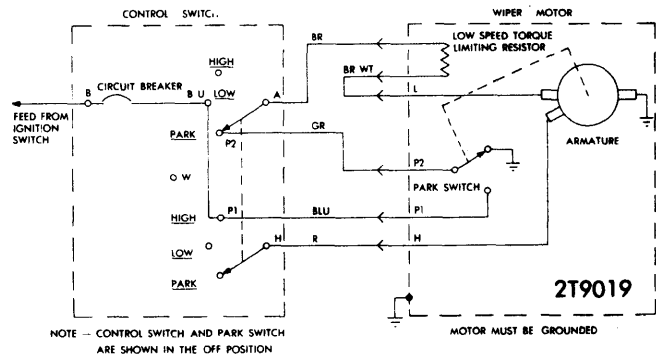

**CHRYSLER CORP. 2-SPEED WIPER SYSTEM
(NON-CONCEALED WIPERS)**

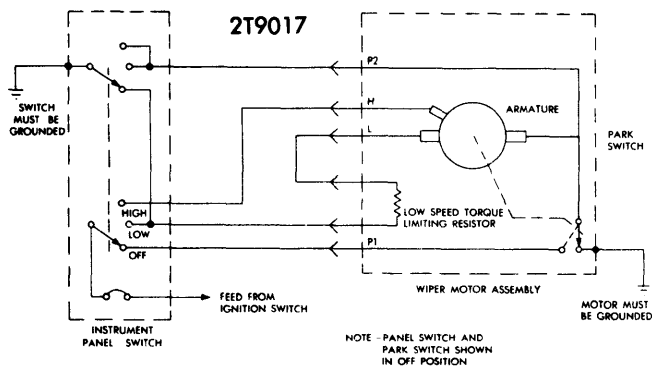

**CHRYSLER CORP. 2-SPEED WIPER SYSTEM
(CONCEALED WIPERS)**

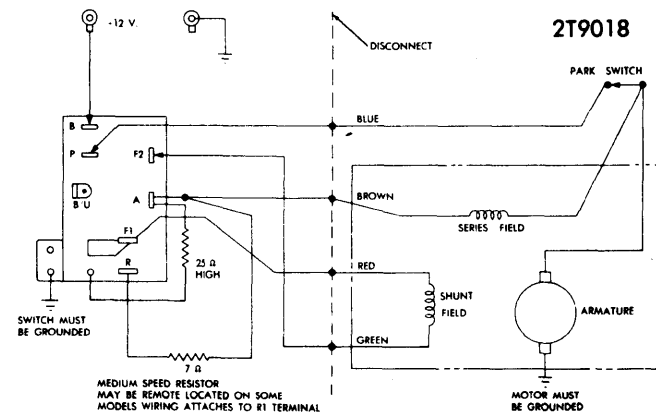

CHRYSLER CORP. 3-SPEED WIPER SYSTEM

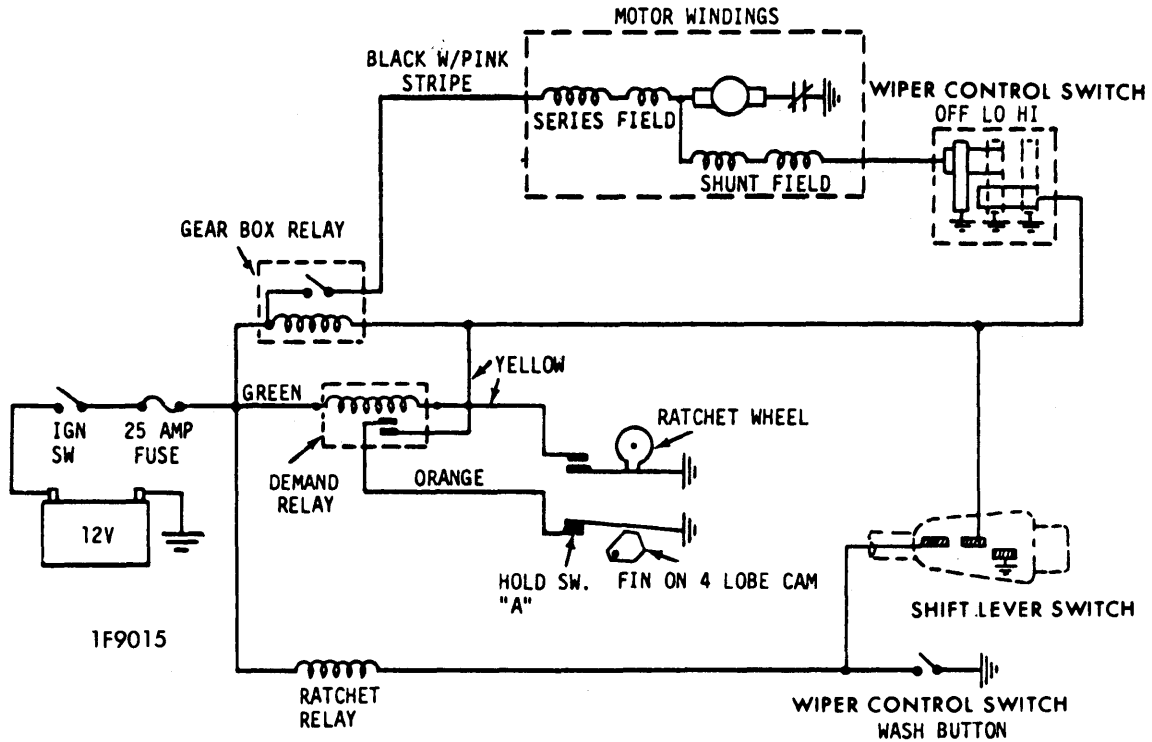

GENERAL MOTORS DEMAND WIPER SYSTEM

1973 Power Seat Controls

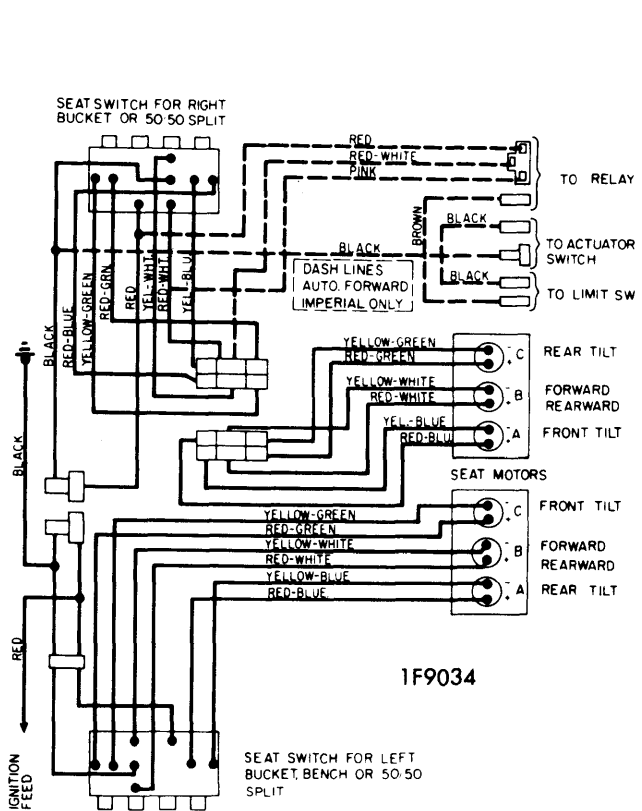

CHRYSLER CORP. POWER SEAT WIRING

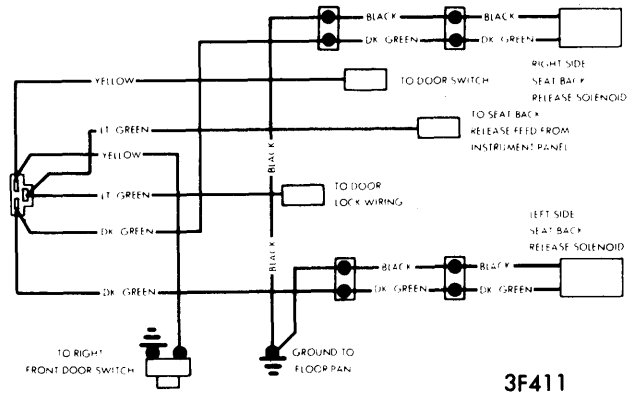

CHRYSLER CORP. SEAT BACK LATCH WIRING

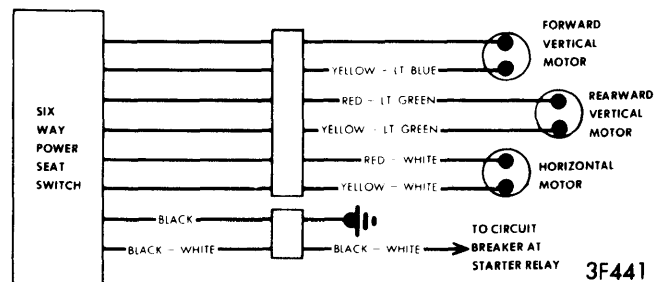

FORD MOTOR CO. 6-WAY POWER SEAT WIRING