

## TOYO DENSO ELECTRONIC IGNITION — HONDA

Accord, Prelude

**NOTE:** Some Honda models use Hitachi distributors. See appropriate article in this section.

### DESCRIPTION

Honda's Toyo Denso electronic distributors consist of a distributor housing, rotor and the distributor cap. The reluctor, stator, magnets, pick-up coil and breaker plate assemblies are all located inside the distributor housing.

**Fig. 1: Disassembled View of Toyo Denso Distributor**

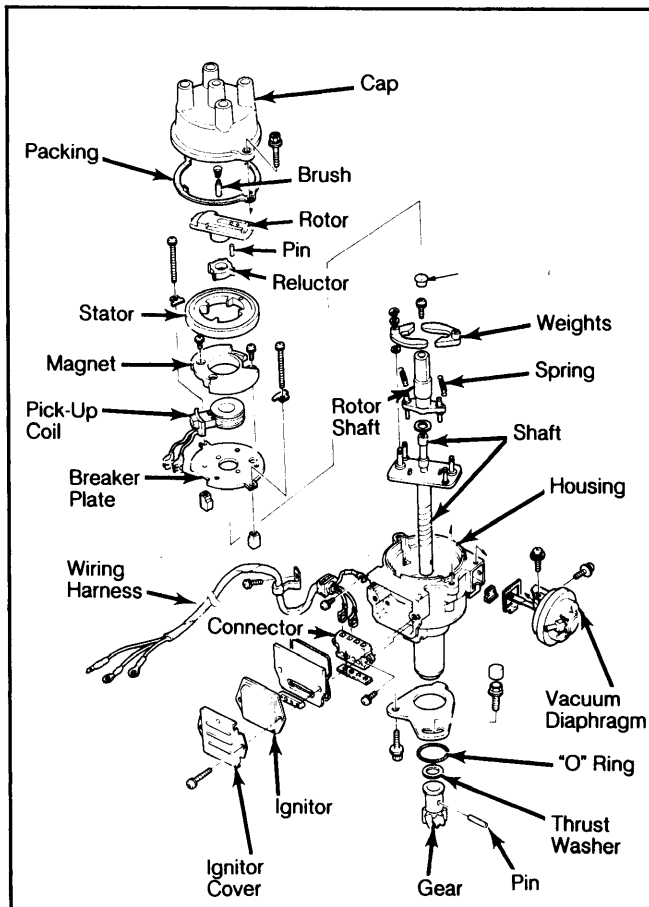

This distributor is used (instead of Hitachi) on some Accord & Prelude models.

Unlike Honda's Hitachi distributors, the ignitor on Toyo Denso distributors is mounted externally on the distributor housing. All models use a centrifugal and vacuum advance system.

### OPERATION

The reluctor, secured to the distributor rotor shaft by a roll pin, turns with the distributor shaft. As it turns, its 4 external teeth come in line with the 4 teeth of the ring-shaped stator.

As the reluctor approaches and passes the stator teeth, variations occur in the magnetic field around them. This causes the pick-up coil to signal the ignitor.

As these signals are received, transistors inside the ignitor are turned off and on. This results in a magnetic field building and collapsing in the primary circuit of the ignition coil. When this field collapses, a voltage surge occurs in the secondary circuit of the ignition coil.

When this occurs, a high voltage spark is fed from the coil, through the distributor rotor and cap to the secondary wiring and spark plugs.

**Fig. 2: Schematic of Ignition System**

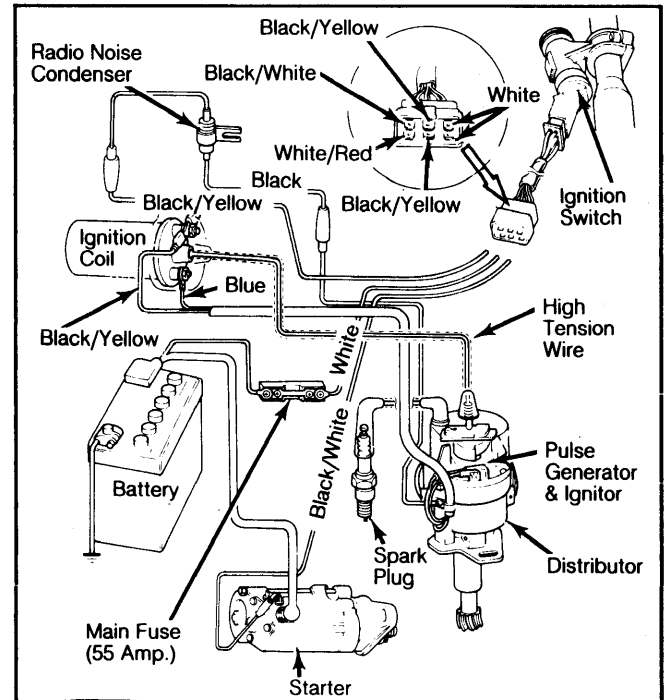

This diagram applies to Accord and Prelude models.

### SPECIFICATIONS

#### CENTRIFUGAL & VACUUM ADVANCE

See appropriate Distributor Specifications Table in this section.

### ADJUSTMENT

**CAUTION:** To avoid damaging the ignition system, never reverse battery polarity. Do not let pick-up coil wires touch ignition wires. Do not do anything that would produce abnormal pulses. Always connect pulse type tachometers to negative terminal of ignition coil. Make sure all wires and cables are connected properly.

#### CAM ANGLE

Cam angle (dwell) is automatically set, and manual adjustment is not required.

#### RELUCTOR-TO-STATOR AIR GAP

1) Align 4 teeth of reluctor with 4 teeth of stator, and check air gap. Check air gap at all teeth as

# Distributors & Ignition Systems

## TOYO DENSO ELECTRONIC IGNITION — HONDA (Cont.)

reluctor is rotated. See Fig. 3. There should be equal air gap at all 4 teeth. If not, check for damage to stator or reluctor.

2) If necessary to adjust, loosen 2 screws securing stator, and reposition stator to provide equal air gaps. Tighten 2 screws.

**Fig. 3: Adjusting Reluctor-To-Stator Air Gap**

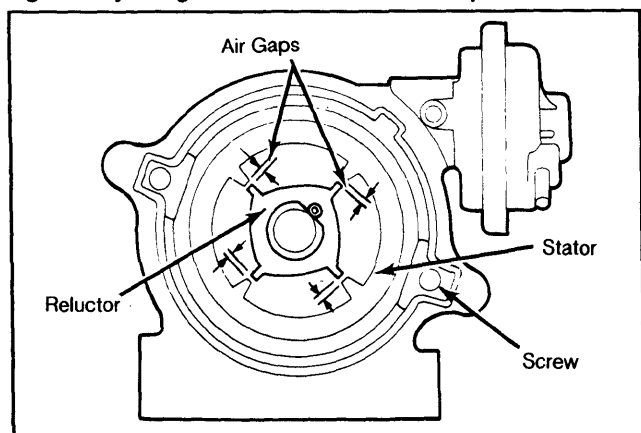

*Air gap should be equal at all teeth.*

### ROTOR-TO-DISTRIBUTOR CAP TERMINAL

Check occasionally for rough or pitted rotor or cap terminals. Scrape or file off carbon deposits. Smooth rotor terminal with an oil stone or No. 600 sandpaper if roughness exists. Apply a thin coat of silicon grease to rotor tip.

### CENTRIFUGAL ADVANCE

1) Disconnect vacuum advance hose from distributor, and pinch end of hose. Connect timing light and start engine. Increase engine speed.

2) Timing mark (T) should appear to move past pointer toward firewall, indicating an increase in ignition advance. If not, check centrifugal advance mechanism for sticking or binding.

### VACUUM ADVANCE

1) Remove distributor cap. Disconnect vacuum hose from distributor vacuum advance. Connect vacuum pump to diaphragm. Gradually draw a vacuum while watching breaker plate movement.

2) Check for smooth operation without binding. If pump indicates a loss of vacuum, replace diaphragm unit. Turn breaker plate right and left to check for free movement.

## TESTING

### BASIC SYSTEM TEST

1) If engine will not start and starter will not crank engine, check battery, main fuse and electrical wiring. Check starter circuit wiring and ignition switch. If engine will not start, but starter cranks engine, hold coil wire 1/4" from coil tower while cranking engine.

2) If there is spark from coil, then hold spark plug wire terminal 1/4" from spark plug while cranking engine.

3) If there is no spark at the plug, check spark plug wire condition, inspect distributor cap and rotor, and as a last resort, replace ignitor on distributor housing. If spark exists at the plug, check fuel system, spark plugs, ignition timing or valve timing.

4) If there was no spark at the coil in step 1), turn ignition switch to the "ON" position. Check voltage between coil primary winding positive terminal and ground. Battery voltage should be found. If not, check wiring from ignition switch to ignition coil.

**Fig. 4: Checking Ignitor Voltage**

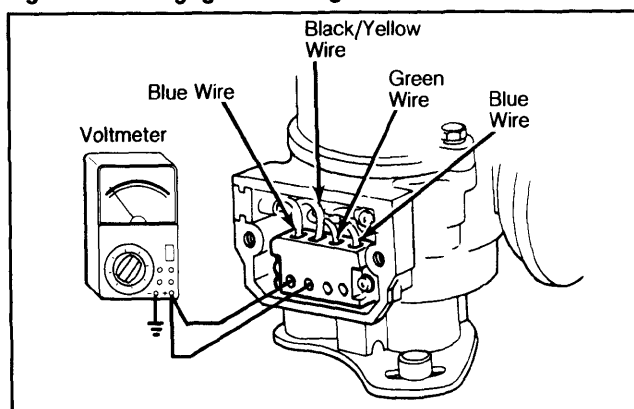

*Battery voltage should be present in both tests.*

5) If battery voltage exists, be sure ignition switch is still in the "ON" position. Check voltage between coil primary winding negative terminal and ground. Again, battery voltage should exist. If not, check wiring from coil primary negative terminal to ignitor. Also check coil primary resistance.

6) If battery voltage was present at negative terminal, check voltage between coil positive and negative terminals with engine cranking. Reading should be 1-3 volts. If within specifications, check primary and secondary coil resistance. Also check spark plug wire resistance.

7) If voltage in step 6) was not 1-3 volts, disconnect lead wires from ignitor. Check voltage on coil side of connector, first between blue wire and black (ground) wire and then between black/yellow wire and black (ground) wire. See Fig. 4. Battery voltage should exist with ignition switch "ON".

**Fig. 5: Checking Continuity at Ignitor Terminals**

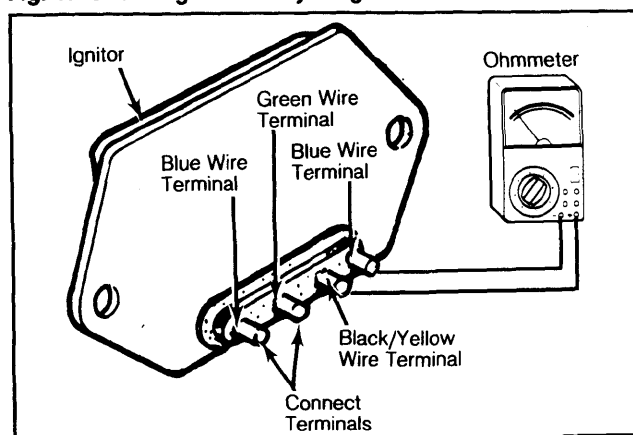

*Test as shown and then reverse ohmmeter connections.*

## TOYO DENSO ELECTRONIC IGNITION — HONDA (Cont.)

8) If not, check wiring from ignition coil to ignitor. Check continuity between ignitor terminals. See Fig. 5. Set ohmmeter to x100 range. Attach positive lead to terminal for black/yellow wire and negative lead to terminal for blue wire. There should be continuity.

9) Then, reverse ohmmeter leads (positive lead to terminal for blue wire, negative lead to terminal for black/yellow wire). There should be no continuity. If incorrect results are obtained, replace ignitor and repeat test.

### COMPONENT TESTS

#### Ignition Coil Primary Resistance

1) Turn ignition switch "OFF" and remove positive and negative wires from ignition coil terminals. Connect an ohmmeter set in the x1 range with one probe touching each primary terminal. See Fig. 6.

**Fig. 6: Checking Ignition Coil Primary Resistance**

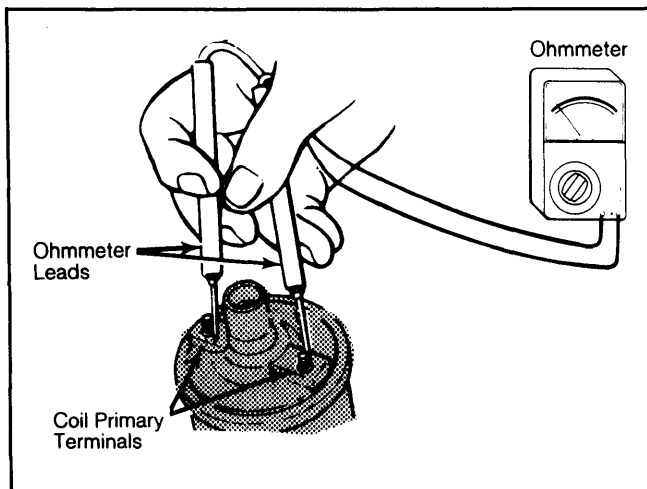

Attach probes to positive and negative terminals.

2) Reading should be 1.06-1.24 ohms. If reading is not to specifications, replace ignition coil.

#### Ignition Coil Secondary Resistance

1) Turn ignition switch "OFF". Set ohmmeter in x1000 range. Connect ohmmeter leads to ignition coil negative terminal (wire removed) and coil tower terminal. See Fig. 7.

2) Resistance should be 7,400-11,000 ohms. If not replace ignition coil.

**Fig. 7: Checking Ignition Coil Secondary Resistance**

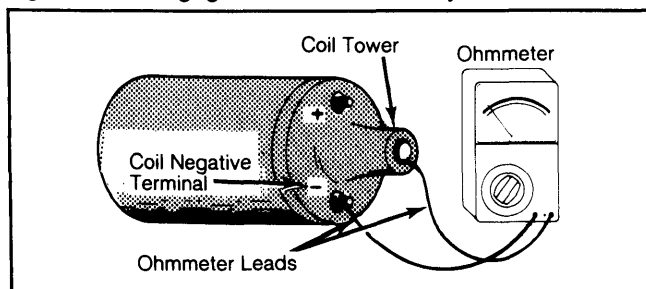

Attach leads to negative terminal and coil tower.

#### Condenser Capacity

Using a condenser tester, check for 0.38-0.56 microfarads.

#### Ignition Wire Resistance

1) Carefully remove wires by pulling on their rubber boots. Do not bend wire or conductor may be broken. Check for corroded condition, cleaning if necessary. Connect ohmmeter probes (set in x1000 scale) to each end of ignition wires.

2) Resistance reading should be 25,000 ohms or less per wire. If not, replace wires.

## OVERHAUL

### DISASSEMBLY

1) Remove spark plug wires and vacuum hoses from distributor. Remove distributor cap. Remove condenser ground wire and disconnect pick-up coil wire connector from distributor. Remove hold-down bolt, lifting distributor from cylinder head.

2) Carefully pry upward on reluctor with 2 screwdrivers, cushioned with rags to prevent damage to distributor housing. Use care not to damage reluctor or stator.

3) Remove advance diaphragm mounting screw. Pull out on diaphragm unit, while pushing down on end of diaphragm arm.

4) Drive roll pin from distributor shaft. Remove shaft and gear from housing. Inspect and replace parts as necessary.

### REASSEMBLY

1) Grease the distributor shaft and rotor shaft. Assemble shafts and secure with screw and rubber plug. Install centrifugal advance weights and springs. Install shaft assembly into distributor housing, with flat surface of rotor shaft facing the ignitor. See Fig. 8.

2) With flat surface still facing ignitor, install washer and gear. Marks on housing and gear should align. Drive in new roll pin.

**Fig. 8: Installing Rotor Shaft and Advance Unit**

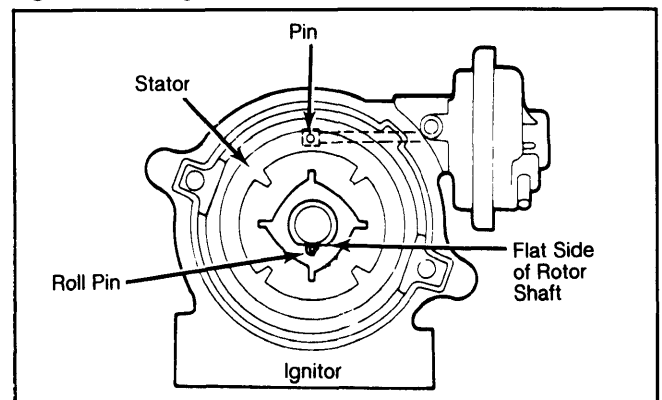

Flat side of rotor shaft should be toward ignitor.

3) Align pin on stator with hole in advance diaphragm arm. See Fig. 8. Drop arm into place over pin. Install and tighten hold-down screws. Install reluctor, and check air gap. Gap should be equal at each tooth. If not, check for damage to stator or reluctor.

4) Inspect rotor and cap for roughness or pitting. Scrape or file off carbon deposits with an oil stone or No. 600 sandpaper. Apply a thin coat of silicon grease to rotor tip.

# Distributors & Ignition Systems

## TOYO DENSO ELECTRONIC IGNITION — HONDA (Cont.)

5) Crank engine until No. 1 piston is at TDC. Install new "O" ring on distributor housing. Position rotor 1/8 turn past firing position for No. 1 cylinder on distributor). See Fig. 9.

**Fig. 9: Aligning Rotor with Mark on Housing**

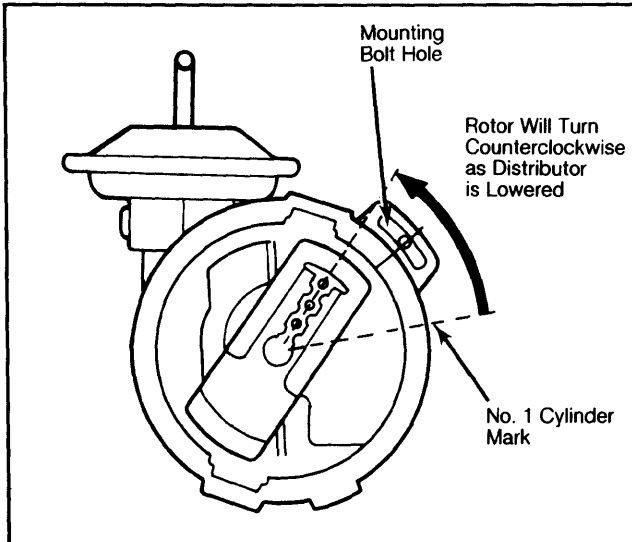

*Position rotor 1/8 turn past No. 1 cylinder mark.*

6) Install distributor. Insert distributor straight into final position. Rotor will turn itself to No. 1 firing position. Mounting bracket should be centered over its bolt hole.

7) Install hold-down bolt and tighten it temporarily. Set ignition timing, and tighten hold-down bolt securely. Install distributor cap, aligning mark on cap with rotor.