

Distributors & Ignition Systems

NIPPONDENSO ELECTRONIC IGNITION

Isuzu I-Mark, P'UP; LUV; Subaru 1600 (2-WD), 1800 (2-WD); Toyota Celica, Corolla, Corona, Cressida, Land Cruiser, Pickup, Starlet, Supra & Tercel

DESCRIPTION

The Nippondenso electronic ignition system includes a breakerless distributor, an ignitor (ignition control unit), a special ignition coil, and ignition switch.

The distributor consists of a housing, rotor, and cap. It contains a signal rotor (timing rotor or reluctor), magnet, and a magnetic pick-up coil assembly. See Fig. 1. On Subaru models, the ignitor is mounted inside the distributor.

On other models, the transistorized ignitor is mounted on the ignition coil housing. Distributors contain both centrifugal and vacuum advance mechanisms.

Fig. 1: Exploded View of Typical Nippondenso Distributor

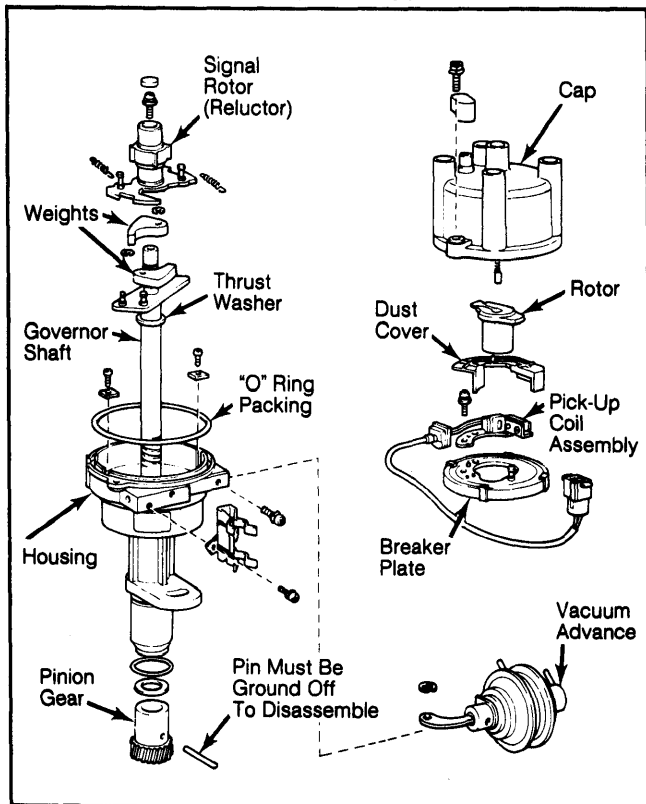

Toyota distributor is shown. Subaru distributors contain an integral ignitor.

OPERATION

As the signal rotor turns with the distributor shaft, its teeth (one for each engine cylinder) pass the magnetic pick-up coil assembly. See Fig. 2.

As the air gap changes with the approach and passing of each tooth, the magnetic field varies. This creates a signal in the pick-up coil assembly. The ignitor senses this signal, and turns the ignition coil primary circuit on and off.

This causes the magnetic field in coil primary circuit to build and collapse, resulting in a voltage surge in the secondary, which fires the spark plugs.

Fig. 2: Schematic of Nippondenso Electronic Ignition Circuit

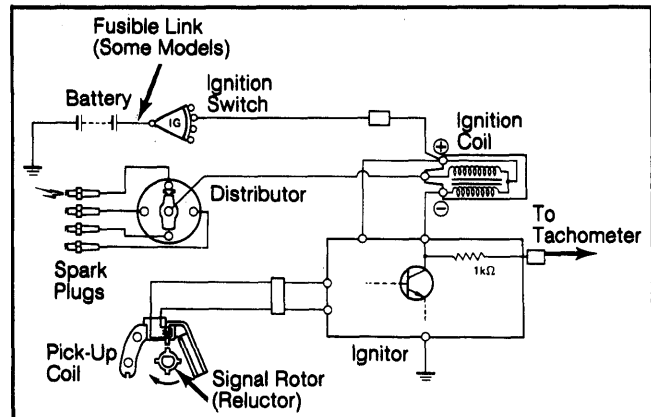

Some models have EFI relays or other minor variations.

SPECIFICATIONS

CENTRIFUGAL & VACUUM ADVANCE

See the appropriate Distributor Specifications Table in this section.

ADJUSTMENTS

SIGNAL ROTOR (RELUCTOR)-TO-PICK-UP COIL AIR GAP

1) Using a flat feeler gauge, check air gap between pick-up coil pole piece and each reluctor tooth. Gaps should be equal and .008-.016" (0.2-0.4mm).

2) If not, loosen screws, and move pick-up coil against feeler gauge of proper thickness. Tighten screws, and recheck air gap.

Fig. 3: Checking Signal Rotor-to-Pick-Up Coil Air Gap

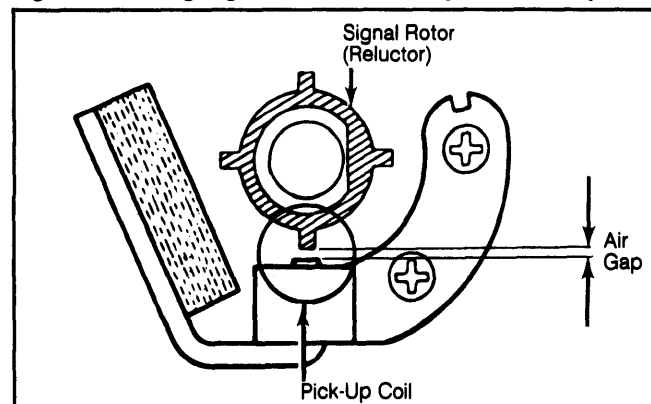

Use feeler gauge to check clearance.

TESTING

CAUTION: The following precautions should be observed while servicing or testing a Nippondenso ignition system.

Be sure all connections are correct, as reverse battery polarity within the system will damage the ignitor (ignition control unit).

NIPPONDENSO ELECTRONIC IGNITION (Cont.)

Do not disconnect battery while engine is running or transistors may be damaged.

If a tachometer is connected to system, connect tachometer positive lead to coil negative terminal.

Be careful when checking systems, as slight variations may occur between models. Connectors and wire colors also may vary from model to model.

Illustrations, although specific to certain models, may not apply totally to all models.

Do not allow water to enter ignitor.

RESISTANCE TESTS

NOTE: All resistance tests should be made with an ohmmeter with the ignition switch in the "OFF" position. If resistance for any test is not within specifications, replace the faulty component.

Primary Coil Resistance

Isolate coil from remainder of system. Connect an ohmmeter, set in x1 range, so leads touch coil positive and negative primary terminals. See Fig. 4 and Ignition Coil Resistance table.

Fig. 4: Checking Coil Primary & Secondary Resistance

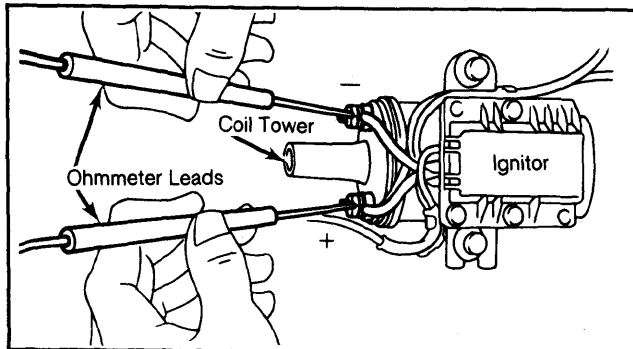

Use an ohmmeter, with ignition switch turned "OFF".

Secondary Coil Resistance

With coil still isolated from rest of system, set an ohmmeter in the x100 range. Connect leads to coil positive terminal and to coil tower (high tension terminal). See Fig. 4 and Ignition Coil Resistance table.

Insulation Resistance

Connect 1 ohmmeter lead to the coil positive terminal and the other to the coil mounting bracket. Reading on all models should exceed 10 megohms (infinity).

IGNITION COIL RESISTANCE (OHMS)

Application	Primary Resistance	Secondary Resistance
Isuzu	1.13-1.53	10,200-13,800
LUV	0.83-1.02	12,150-14,850
Toyota		
Celica, Corona, & Tercel	0.8-1.1	10,700-14,500
Corolla	0.8-1.1	11,500-15,500
Cressida, Land Cruiser, & Supra	0.5-0.7	11,500-15,500
Pickup	0.4-0.5	8,500-11,500
Starlet	1.3-1.7	10,000-15,000
Subaru	1.06-1.30	12,150-14,850

High Tension Wire Resistance

1) Set ohmmeter to x1000 scale and attach leads to each end of high tension wire. On Isuzu and LUV, resistance should not exceed 73,500 ohms per foot.

2) On all other models, resistance should not exceed 25,000 ohms. If it does, replace wires.

Pick-Up Coil Resistance

1) Using an ohmmeter set in the x100 range, measure pick-up coil resistance at distributor connector. See Fig. 5.

Fig. 5: Checking Pick-Up Coil Resistance

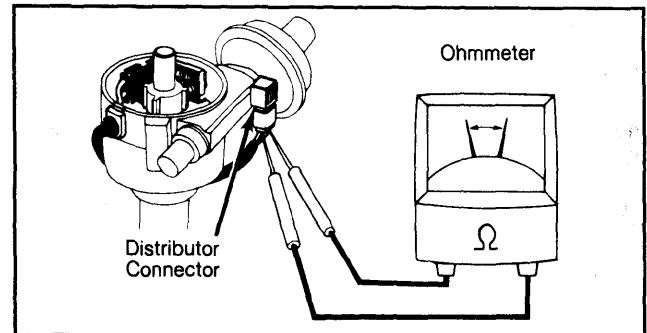

Connect ohmmeter leads to distributor connector terminals.

2) Check resistance value against Pick-Up Coil Resistance table. If not to specifications, replace pick-up coil assembly. Also check wires for shorts or opens.

PICK-UP COIL RESISTANCE (OHMS)

Application	Resistance
Cressida, Starlet & Supra	140-180
All Other Models	130-190

IGNITOR TESTS

Subaru Models

1) Turn ignition "ON", but do not start engine. Connect voltmeter negative lead to a good engine ground. Connect positive lead to ignition coil negative terminal.

2) Voltmeter should read battery voltage (12 volts). If not, proceed to step 4). If battery voltage is present, turn ignition switch "OFF", and check air gap at distributor pick-up coil.

3) If not to specifications, adjust air gap. If OK, disconnect all wires from ignition coil primary terminals, and check both primary and secondary coil resistance. If not to specifications, replace ignition coil. If OK, proceed to step 9).

4) Connect voltmeter negative lead to a good engine ground. Connect positive lead to ignition coil positive terminal. Turn ignition switch "ON". Voltmeter should again read battery voltage.

5) If not, check the power supply harness, ignition switch, fuse, and noise suppressor condenser. Repair or replace components, as necessary.

6) If battery voltage was present in step 4), turn ignition switch "OFF". Disconnect the distributor wire from the ignition coil negative terminal. Turn ignition switch "ON".

7) Voltmeter should read battery voltage. If so, proceed to step 9). If not, turn ignition switch "OFF", and disconnect tachometer wire from ignition coil negative terminal. Turn ignition switch back to "ON" position.

Distributors & Ignition Systems

NIPPONDENSO ELECTRONIC IGNITION (Cont.)

8) If battery voltage is not present now, replace ignition coil. If voltmeter indicated battery voltage in step 7) with tachometer disconnected, check tachometer system for short circuit. Repair or replace, as necessary.

9) If ignition coil resistance was OK in step 3) or if battery voltage at negative coil terminal was present in step 7), check for short circuit or open circuit between ignitor and both the ignition coil and distributor pick-up coil

10) If wiring from ignitor is OK, replace pick-up coil and ignitor.

Isuzu, LUV, & Toyota Models

1) Turn ignition switch "ON". Connect negative voltmeter lead to ground and positive lead to ignition coil positive terminal. See Fig. 6. Voltage reading should be 12 volts.

Fig. 6: Checking Isuzu, LUV, & Toyota Ignitor

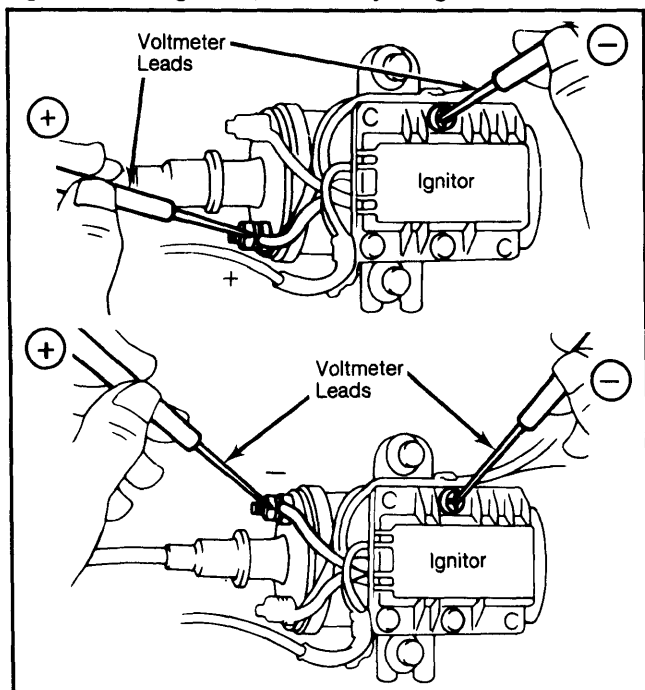

Check voltage at both positive and negative coil terminals.

2) With negative lead still attached to ground, connect voltmeter positive lead to ignition coil negative terminal. See Fig. 6. Voltage should read 12 volts. Unplug wiring harness connector from distributor.

Fig. 7: Checking Ignitor Operation with 1.5 Volt Battery

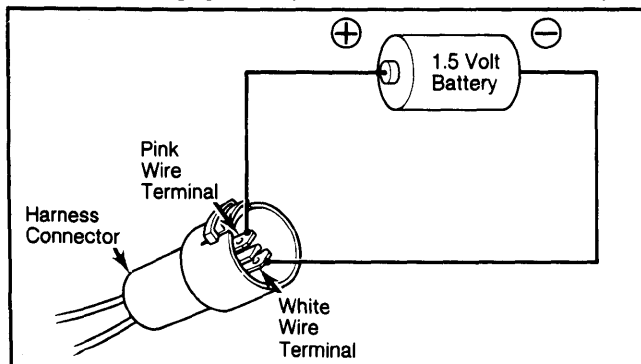

Apply voltage less than 5 seconds.

CAUTION: In step 3) below, do not apply voltage for more than 5 seconds.

3) Using a 1.5-volt dry cell battery (no more than 3-volt battery), connect battery positive pole to Pink wire terminal. See Fig. 7. Connect negative pole to White wire terminal.

4) Voltage at negative terminal of coil should be as indicated in Ignitor Test Voltage Specifications table.

IGNITOR TEST VOLTAGE SPECIFICATIONS

Application	Volts
Isuzu and LUV	5
Toyota	
Celica	8-10
Corolla	5-8
Corona	5
Cressida	5-8
Land Cruiser	5-8
Pickup	8-10
Starlet	3
Supra	8-10
Tercel	5-8

OVERHAUL

NOTE: Procedure may vary slightly between Subaru (with integral ignitor) and other models.

DISASSEMBLY

1) Remove distributor cap rotor, dust cover, and packing. Remove pick-up coil assembly, ignitor (Subaru only), vacuum advance mechanism, breaker plate and drive pinion.

2) Remove 2 screws from bottom of distributor housing, and using a plastic hammer, carefully drive out shaft. Remove thick washer, bearing, thin washer, spring, and blue washer from shaft.

3) Note location of thin and thick governor springs, and remove springs. Remove cam cap, signal rotor (reluctor), weight snap ring and weights.

REASSEMBLY

1) Assemble in reverse order of disassembly, noting the following: Lightly grease signal rotor (reluctor) inner surface.

2) Install on shaft aligning proper mark on stopper plate ("8" on Cressida; "10" on Corolla; "10.5" on Isuzu, LUV, and Land Cruiser; "11" on Subaru, Celica, and Corona; "12" on Pickup and Tercel; and "14" on Starlet.)

NOTE: On Supra models, install distributor shaft so that stopper pin and governor shaft stopper pin are on same side. Install signal rotor on governor shaft with cutout portion of shaft positioned to right of governor stopper pin.

3) When installing breaker plate, align 4 clips of plate with 4 grooves in housing.

4) When replacing pinion, replace pin and pinion as a set. Adjust air gap between signal rotor and pick-up coil.