

Distributors & Ignition Systems

MITSUBISHI ELECTRONIC IGNITION

Arrow Pickup, Champ, Colt, Challenger, Ram-50 Pickup, Sapporo; Courier; and Mazda GLC, 626, B2000 Pickup

DESCRIPTION

Mitsubishi breakerless ignition consists of an electronic control module (ignitor), ignition coil, pick-up coil, and distributor.

On Courier models with the 2300 cc engine, the control module is mounted with the ignition coil on the left front fender apron. On all other models, the control module is mounted inside the distributor with the pick-up coil assembly.

The Mazda 626 utilizes a water thermo valve to cut advance when the engine is cold. Federal B2000 Pickups use a vacuum delay valve during acceleration, and Calif. B2000 Pickups use both a water thermo valve and vacuum delay valve. On Calif. models, vacuum advance is cut when engine is cold and delayed during acceleration.

OPERATION

Whenever the ignition switch is "ON", the primary circuit of the ignition coil is energized. As the distributor shaft rotates, the armature (reluctor) rotates inside the magnetic pick-up coil (stator) assembly.

As the teeth of the armature pass the pegs of the pick-up coil, a signal is sent to the control module (ignitor). The module then breaks the primary circuit in the coil. This causes a high voltage surge in the coil secondary circuit, firing the spark plugs.

SPECIFICATIONS

CENTRIFUGAL & VACUUM ADVANCE

See the appropriate Distributor Specifications Table in this section.

Fig. 1: Wiring Schematic of Mitsubishi Electronic Ignition System With Internal Control Module

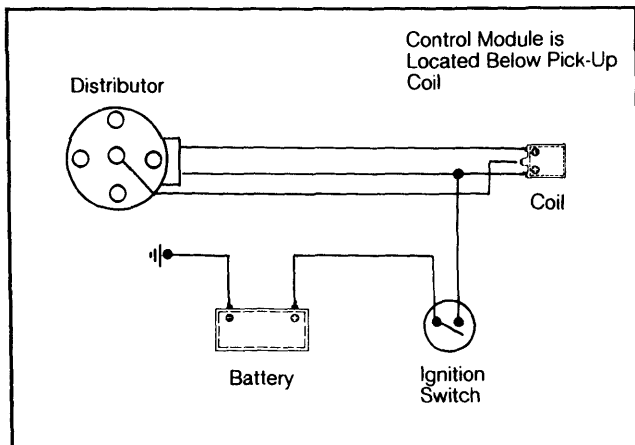

Schematic is for all models except Courier 2300 cc engine.

ADJUSTMENTS

NOTE: Air gap is not adjustable if model is not listed in the table.

RELUCTOR-TO-PICK-UP COIL AIR GAP

Align teeth of reluctor with pegs of pick-up coil and breaker plate assembly. Using a feeler gauge, check for correct air gap. To adjust, loosen set screws, and move pick-up coil on GLC (RWD). Bend pick-up coil on Courier 2300 cc.

PICK-UP COIL AIR GAP

Application	In. (mm)
Courier 2300 cc	.016 (.41)
GLC (RWD)	.012-.018 (.30-.45)

NOTE: No adjustments should be attempted on the ignition system except pick-up coil air gap, spark plug gap, and initial ignition timing.

TESTING

NOTE: Be sure battery is at full charge and in good condition before making any tests. Check all wiring harnesses, ignition switch, coil and spark plug cables and connectors.

HIGH VOLTAGE TEST

Connect a remote starter switch in the starting circuit. Remove coil wire from distributor cap. Turn ignition switch "ON" and hold coil wire 1/4" from cylinder block. Crank engine. If no spark or only a weak spark results, perform the following tests.

IGNITION COIL RESISTANCE TEST

1) Turn ignition switch "OFF". Remove wires from coil primary terminals to isolate it from the rest of the system. Set an ohmmeter in the low scale, and attach its leads to the coil positive and negative terminals. Check primary resistance reading. Replace coil if not to specifications.

2) Set ohmmeter in x1000 scale, and attach leads to the coil positive terminal and secondary tower. Check secondary resistance reading. Replace coil if not to specifications.

IGNITION COIL RESISTANCE SPECIFICATIONS (OHMS)

Application	Primary	Secondary
Chrysler Corp.	.70-.85	9000-11,000
Courier	.81-.99	6800-9200
Mazda GLC		
(FWD) ¹	Continuity	10,000-30,000
(RWD) ¹	1.04-1.27	
Mazda B2000 ¹	.81-.99	
Mazda 626 ¹	1.04-1.27	

¹ — With coil at normal operating temperature.

MITSUBISHI ELECTRONIC IGNITION (Cont.)

MAGNETIC PICK-UP COIL RESISTANCE TEST

1) Turn ignition switch "OFF". Set an ohmmeter in the x100 scale. Attach leads to pick-up coil's distributor connector terminals. See Fig. 2.

Fig. 2: Checking Pick-Up Coil Resistance

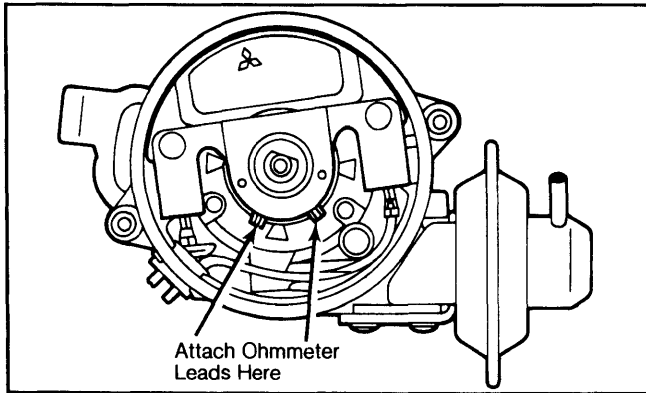

Attach ohmmeter leads to points shown.

2) Compare resistance readings obtained with those given in the table.

PICK-UP COIL RESISTANCE

Application	Ohms
Courier ¹	
2000 cc	945-1155
2300 cc	760-840
Chrysler Corp.	920-1120
Mazda 626 and B2000 ¹	945-1155

¹ — Measure resistance at 68°F (20°C).

NOTE: Specifications for other models are not available from manufacturer.

IGNITION MODULE TEST

Chrysler Corp.

Connect the ignitor, lamp, and battery as shown in Fig. 3. Using a dry cell battery or continuity

Fig. 3: Checking Chrysler Corp. Ignitor with Battery and Test Lamp

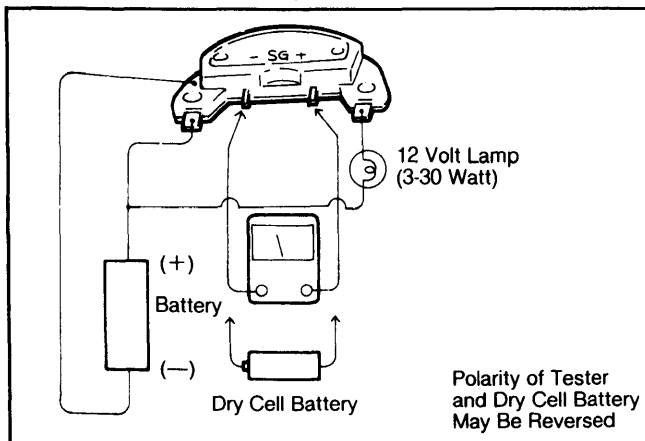

Use low-voltage dry cell battery or ohmmeter.

tester, apply voltage to the signal input terminal of the ignitor unit. Lamp should light when voltage is applied, and go out when voltage is removed. If not, ignitor is bad.

NOTE: This test can only determine when ignitor is bad. Even if ignitor tests out as good, it could still be defective.

Courier (2300 cc)

1) Connect a test light (3.4 watts) to the ignition coil positive and negative terminals. See Fig. 4. Attach one end of a jumper wire to positive terminal of ignition coil. Disconnect the 2-pin connector.

2) Attach other end of jumper wire to the red wire terminal on the module side of the connector. Turn the ignition switch "ON". The test light should come on. The test light should go out when the jumper wire is disconnected.

3) If test light does not function as stated, retest to make sure bulb is OK and that all connections are tight. If results are still improper, replace control module and retest.

Fig. 4: Checking Courier 2300 cc Ignition Control Module

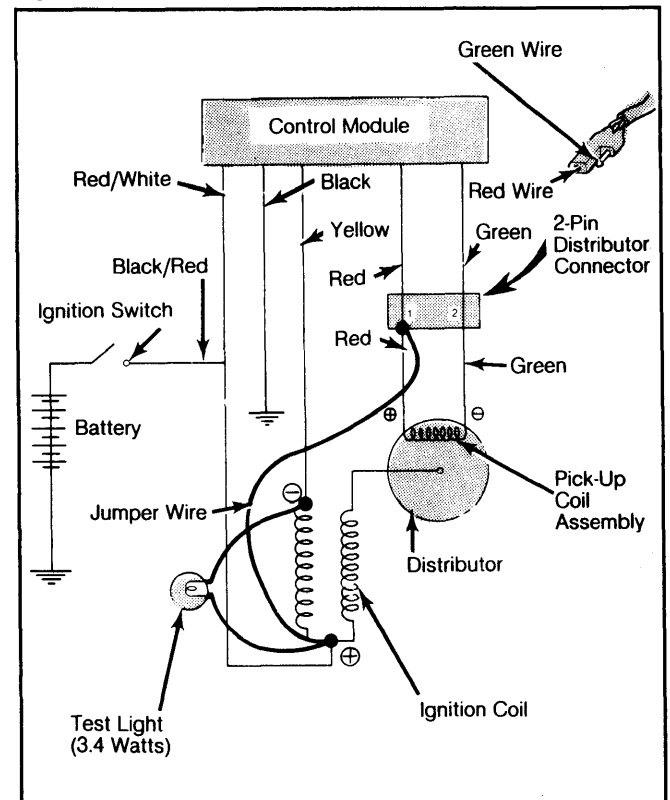

Turn ignition switch on; test light should come on.

SECONDARY WIRE RESISTANCE TEST

1) Test coil and spark plug cables with an ohmmeter. Do not puncture secondary wires when making the resistance check. Connect leads to each end of the cable.

2) Resistance for Courier vehicles should not exceed 570 ohms per inch. For Mazda vehicles, resistance should not exceed 16,000 ohms for each 39" (1 m). For Chrysler Corp. vehicles resistance should not exceed 22,000 ohms per cable.

Distributors & Ignition Systems

MITSUBISHI ELECTRONIC IGNITION (Cont.)

OVERHAUL

**CHRYSLER CORP., COURIER 2000 cc
& MAZDA**

Disassembly

1) Remove distributor cap, remove rotor.

Remove governor assembly. Note location of 2 different governor springs, so they may be reassembled in original location. Remove attaching screws, then remove pick-up coil and IC ignitor assembly.

NOTE: As governor assembly locking bolt is very tight, a spanner may slip. Use either a box wrench or socket wrench.

2) Pull out the ignitor carefully from pick-up coil (if applicable). Remove the vacuum control unit. Remove the breaker assembly. Remove pin holding gear to shaft and remove gear after marking gear and shaft for reassembly reference. See Fig. 5.

NOTE: DO NOT clean grease off back of IC ignitor, as it is necessary for heat transfer.

Reassembly

1) Reverse removal procedure. Inspect cap and rotor for cracks and deposits on inside surfaces. Be sure no metallic dust or filings adhere to breaker assembly, and that is clean prior to reassembly.

2) Check driven gear for wear and shaft for play in thrust direction. Align match marks when installing driven gear. See Fig. 5.

Fig. 5: Installing Driven Gear on Distributor Shaft

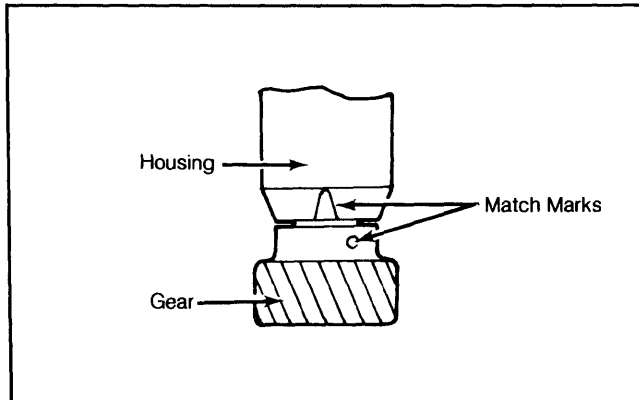

Align match marks and install pin.

COURIER 2300 cc

Disassembly

1) Remove distributor cap and rotor. Remove cover, gasket, and grommet. Remove clips. Drive roll pin from reluctor and remove reluctor. Remove clip holding vacuum diaphragm link. Remove vacuum control unit.

2) Remove pick-up coil assembly. Drive lock pin from driven gear and remove gear. Remove governor and shaft assembly from distributor housing.

Reassembly

Reverse disassembly procedure. When installing cam, align marks on distributor housing and gear. Align rotor metal end with clip mounting lug on side of distributor with mounting slot.

Fig. 6: Exploded View of Mazda Distributor

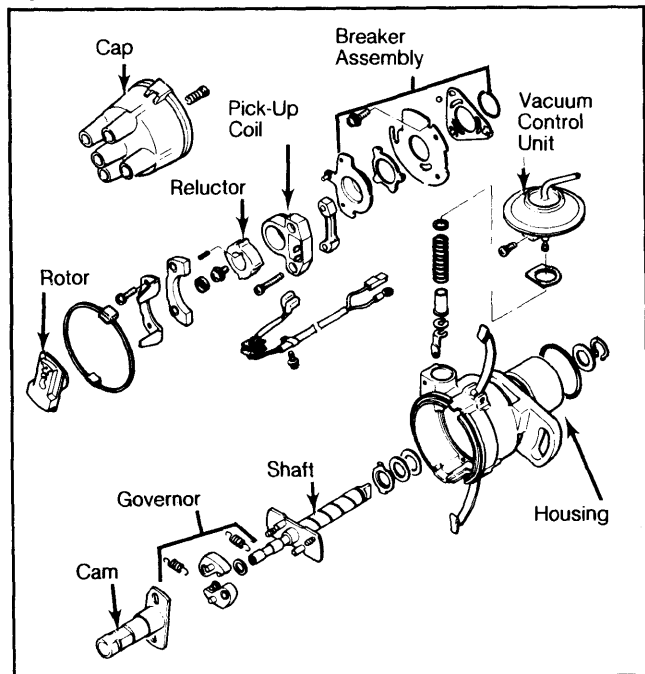

GLC model is shown, others are similar.

Fig. 7: Exploded View of Chrysler Corp. Distributor

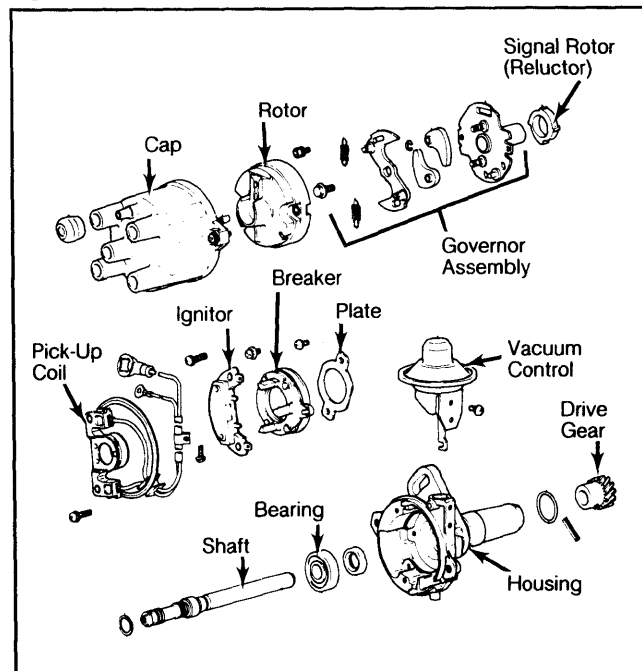

Courier 2000 cc model is similar.