

DUCELLIER ELECTRONIC IGNITION — RENAULT

Fuego Turbo

DESCRIPTION

The electronic ignition system used by Renault in the Fuego Turbo includes a computer, distributor, ignition coil, and numerous sensors. See Fig. 1. The ignition coil, which is part of the computer assembly, may be replaced separately if it is determined to be faulty.

Fig. 1: Wiring Diagram for Renault Fuego Turbo

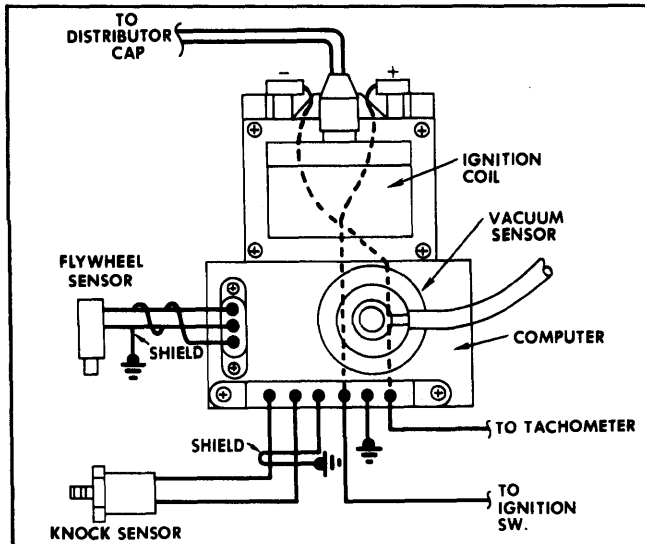

As engine speed and crankshaft position are determined by the preset magnetic position sensor, the distributor's only function is to distribute the spark to the correct spark plug at the proper time.

The vacuum sensor, which cannot be removed from the computer housing, supplies the computer with engine load conditions. The computer also receives information from a spark knock (detonation) sensor.

The flywheel has 44 evenly spaced teeth around its circumference. Two of these have been removed 90° before top dead center and two have been removed 90° after top dead center. This is to provide precise timing marks at 90° before and after top dead center positions. Therefore there are actually only 40 flywheel teeth.

OPERATION

Engine speed and crankshaft (piston) position are determined by the non-adjustable magnetic position sensor rather than the distributor. It indicates position of top dead center and bottom dead center, as well as engine speed.

The vacuum sensor, mounted permanently on the computer housing, appears identical to vacuum diaphragms found on conventional ignition systems. However, the internal components differ greatly. Attempts to remove the vacuum sensor will break a small diameter wire leading into the computer, rendering it useless.

As the engine operates and the crankshaft flywheel turns, information is received by the computer indicating engine speed and crankshaft position. The vacuum sensor informs the computer of engine load conditions. See Fig. 2.

Fig. 2: Relationship of Computer and Ignition Coil

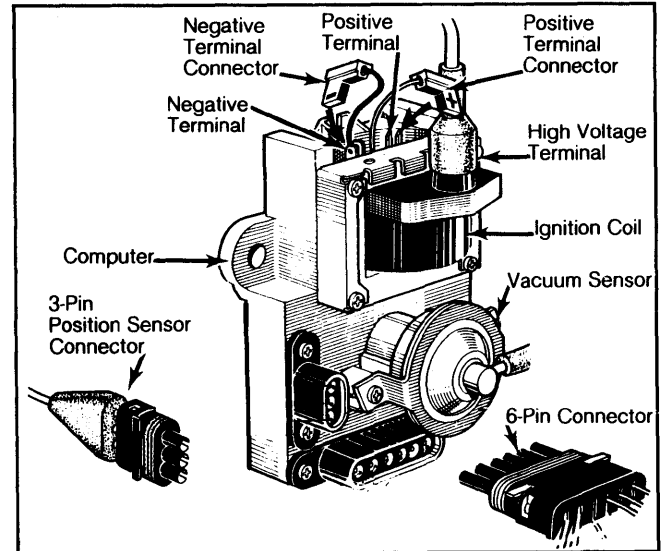

Vacuum sensor cannot be removed from computer.

The computer then interprets the information received, and sets the ignition advance ratio. The computer then opens and closes the primary circuit of the ignition coil, causing a build-up and collapse of the coil's magnetic field.

This in turn, causes a voltage surge in the secondary circuit of the coil. The distributor then furnishes spark to the appropriate spark plug in the correct firing order.

If the spark knock sensor detects detonation, a signal is sent to the computer. In such cases, timing will be retarded by 6°.

SPECIFICATIONS

The Fuego Turbo distributor has neither centrifugal nor vacuum advance mechanisms. Vacuum sensor is located on computer. Advance curve reference is indicated on a label attached to the computer.

ADJUSTMENT

There is no adjustment of magnetic position sensor. Distributor does not have a pick-up coil or reluctor. Ignition timing advance valve at idle speed can be checked, but cannot be adjusted. Checking for computer malfunction would be difficult, if advance were adjustable.

TESTING

CAUTION: When conducting tests, do not short out high tension current on computer housing. Do not ground ignition coil low tension or high tension windings, the primary terminals. Do not attempt to remove computer's vacuum sensor.

VISUAL SYSTEM CHECKS

Check spark plugs, spark plug wires, distributor cap and rotor, and ignition coil high tension wire. Also

Distributors & Ignition Systems

DUCELLIER ELECTRONIC IGNITION — RENAULT (Cont.)

check condition of harness connectors attached to computer. Repeatedly disconnect and reconnect these connectors. Clean terminals if necessary. Always do this before replacing any component.

SYSTEM HIGH VOLTAGE CHECK

1) Disconnect coil high voltage wire from distributor cap. Hold wire approximately 3/4" from cylinder block. Crank engine, but do not start it.

CAUTION: Never ground high voltage wire against computer, as permanent damage will result.

2) If good spark results, check carburetion, engine mechanical condition, and initial advance setting. If no spark or poor spark results, proceed to the following checks.

VACUUM SENSOR CHECK

1) Stabilize engine speed at 3000 RPM. Disconnect vacuum hose from vacuum sensor.

2) If engine speed drops, vacuum sensor is operating properly. If engine speed does not drop, check condition of vacuum hose. If it is bad, replace hose and repeat check again. If hose condition was good, replace computer.

COIL VOLTAGE CHECK

1) Turn ignition "ON", but do not start engine. Connect voltmeter positive lead to coil positive terminal. See Fig. 3. Coil connectors should be on terminals.

Fig. 3: Checking Voltage at Positive Coil Terminal

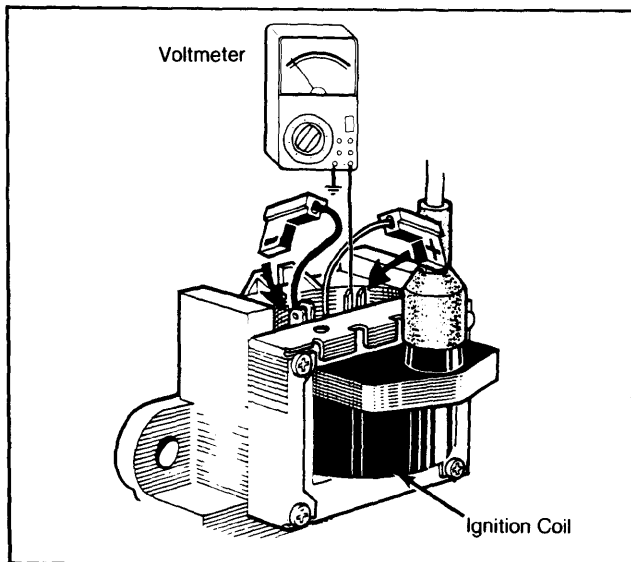

This is a preliminary check to determine system condition.

2) Connect negative lead to vehicle ground. Reading should be at least 9.5 volts. If good, proceed to Position Sensor Check. If less than 9.5 volts are read, proceed with next check.

POWER SUPPLY CHECK

1) Disconnect 6-pin connector from computer. Turn ignition "ON". Connect voltmeter positive lead to pin 1 of harness connector. See Fig. 4. Connect negative lead to vehicle ground.

Fig. 4: Computer and Harness Connector Test Terminals

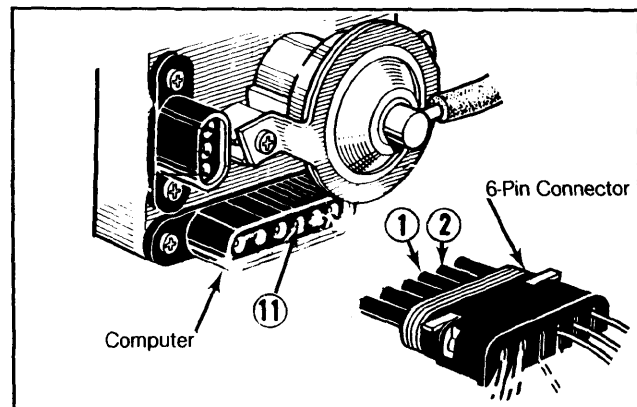

Use this illustration for power supply, ground circuit, ignition coil feed, and connector checks.

2) Crank engine, but do not start it. Reading again should be 9.5 volts or more. If so, proceed to next check. If not, check battery voltage, recharge battery, check lead wires from module to ignition switch.

GROUND CIRCUIT CHECK

1) Disconnect 6-pin connector from computer. Turn ignition "OFF". Connect ohmmeter leads to pin 2 of harness connector and to vehicle ground. See Fig. 4.

2) Reading should be 0 (zero) ohms. If so, proceed to next check. If not, check computer ground wire for breaks, cuts or corrosion.

IGNITION COIL FEED CHECK

1) Disconnect 6-pin connector from computer. Turn ignition "OFF". Disconnect connector from positive terminal of ignition coil. Connect ohmmeter leads to cavity 11 of computer and to connector removed from positive coil terminal. See Fig. 4.

2) A reading of 0 (zero) ohms should be indicated. If so, proceed to next check. If not, replace computer.

6-PIN CONNECTOR CHECK

1) Connect 6-pin connector to computer. See Fig. 4. Turn ignition switch "ON". Disconnect connector from ignition coil positive terminal. Connect voltmeter positive lead to this connector. Attach negative lead to ground.

2) A reading of at least 9.5 volts should be indicated. If so, proceed to next check. If not, slightly shake or wiggle connector assembly. If problem continues, replace 6-pin connector.

NOTE:

Testing has already established that you have power to the 6-pin connector, as well as, continuity between terminal 11 of computer and connector for ignition coil positive terminal. If there is no voltage at positive connector terminal, the 6-pin connector must be at fault.

POSITION SENSOR CHECK

1) Disconnect 3-pin connector from computer. See Fig. 5. Turn ignition switch "OFF". Attach ohmmeter leads to terminals 4 and 5 of 3-pin harness connector.

DUCELLIER ELECTRONIC IGNITION — RENAULT (Cont.)

Fig. 5: Connector Terminals for Magnetic Position Sensor

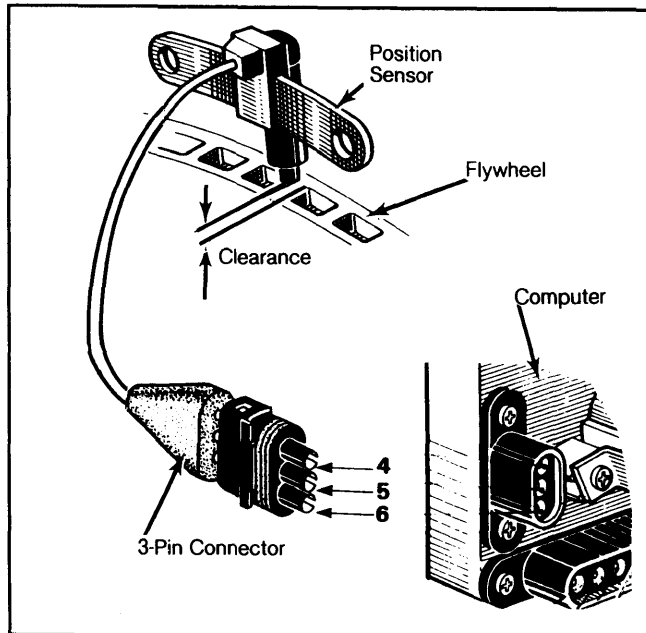

Use this illustration for position sensor, sensor insulation, and position sensor clearance checks

2) Resistance should read 100-200 ohms. If so, proceed to next check. If not, replace magnetic position sensor.

SENSOR INSULATION CHECK

1) Disconnect 3-pin connector. See Fig. 5. Turn ignition "OFF". Connect ohmmeter leads first to terminals 5 and 6 and then to terminals 4 and 6.

2) In both instances, an infinite reading should be indicated. If so, proceed to next check. If not, replace magnetic position sensor.

NOTE: In case of infinite readings, be sure that the ohmmeter probe is properly inserted to touch bottom of terminal.

POSITION SENSOR CLEARANCE CHECK

1) Using a plastic feeler gauge, check clearance between flywheel and magnetic position sensor. See Fig. 5.

2) Clearance should be .02-.06" (.5-1.5 mm). If so, proceed to next check. If not, replace sensor.

COMPUTER CHECK

1) Be sure all connectors are attached to computer. Disconnect harness connectors from coil primary terminals. Install 12-volt test lamp between 2 connectors just removed. See Fig. 6.

2) Crank engine. At cranking speed, lamp should flicker. If so, proceed to next check. If not, replace computer.

Fig. 6: Test Lamp Hookup for Checking Computer

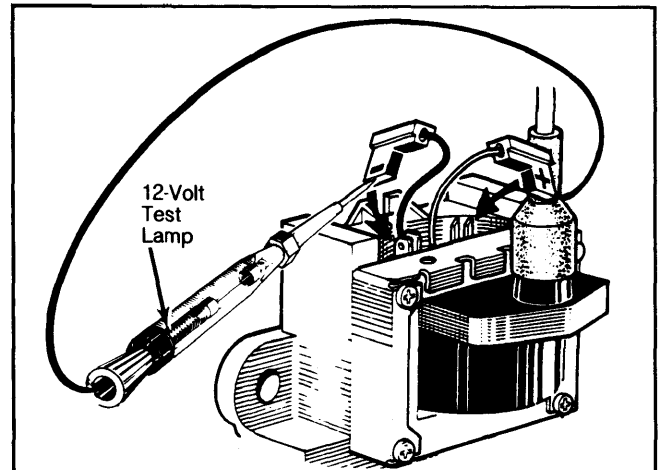

Attach 12-volt lamp to disconnected coil primary leads.

IGNITION COIL RESISTANCE CHECK

CAUTION: When resistance checks are complete, be sure wires are reattached to proper terminals. Red wire goes on positive terminal. Black wire goes on negative terminal.

Secondary Resistance

1) Disconnect harness connectors from ignition coil primary wires. Disconnect high tension wire from coil. Turn ignition "OFF". Set ohmmeter to x1000 scale. Attach ohmmeter leads to coil positive terminal and to coil high voltage terminal.

2) Ohmmeter should read 2500-5500 ohms. If so, check primary resistance. If not, replace ignition coil.

Primary Resistance

1) Remove connectors from coil primary terminals. Turn ignition "OFF". Set ohmmeter to x1 scale. Attach ohmmeter leads to coil primary terminals.

2) Reading should be .4-.8 ohm. If so, but there is no high voltage, replace computer. If resistance is not to specification, replace ignition coil.

SPARK KNOCK SENSOR CHECK

1) Attach timing light according to manufacturer's instructions. Start engine and run it at idle speed. Using a brass jet, tap lightly and repeatedly on cylinder head near spark knock detector.

2) Do not tap directly on sensor. Timing advance should drop by 6° as a result of the tapping. If not, replace sensor unit.

OVERHAUL

As the distributor has no reluctor, pick-up coil, nor centrifugal or vacuum advance, overhaul procedures are simple. Remove distributor cap and rotor. Remove pin from drive gear. Check shaft for burrs, and remove shaft from housing. Reassemble in reverse order.