

TOYOTA VACUUM DIAGRAMS (Cont.)

Fig. 3: Cressida

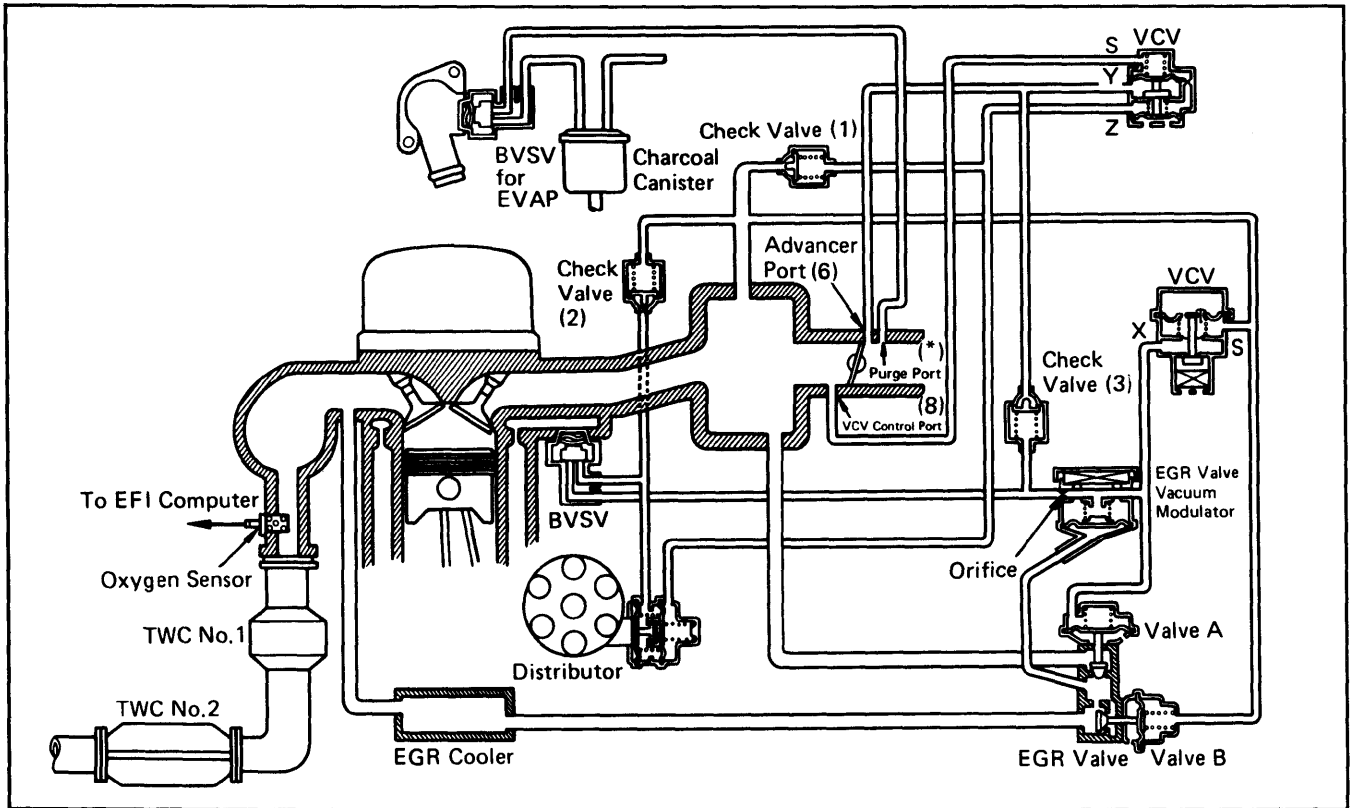
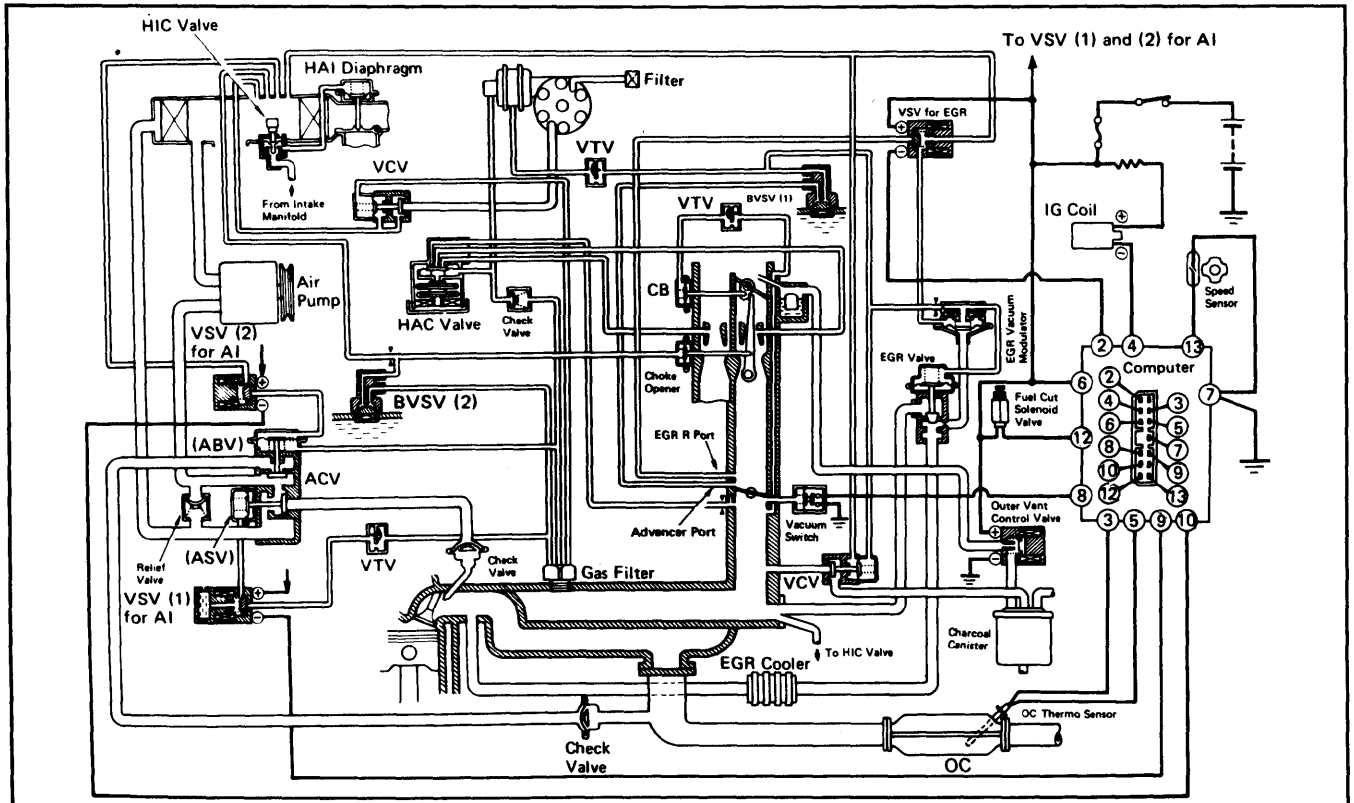

Fig. 4: Land Cruiser



1982 Exhaust Emission Systems

TOYOTA VACUUM DIAGRAMS (Cont.)

Fig. 5: Pickup Cab & Chassis

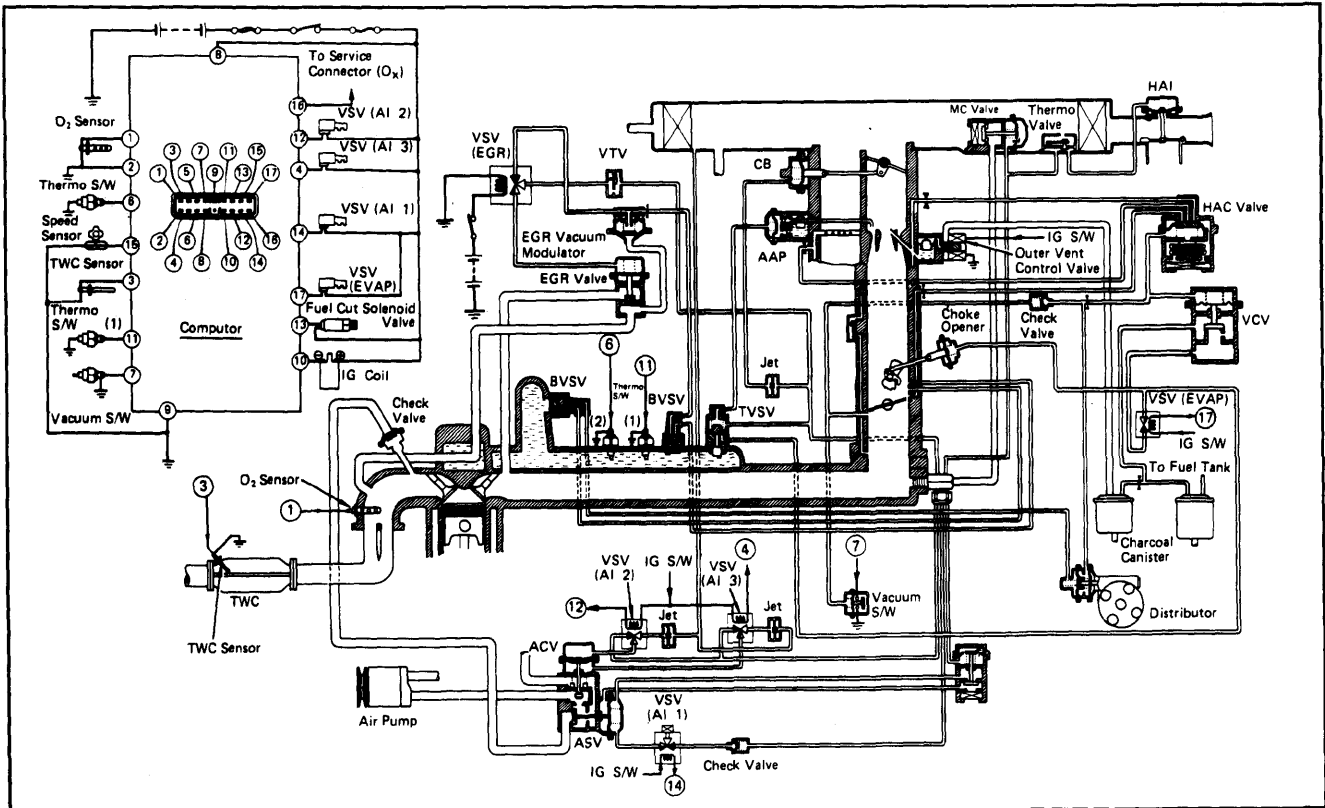
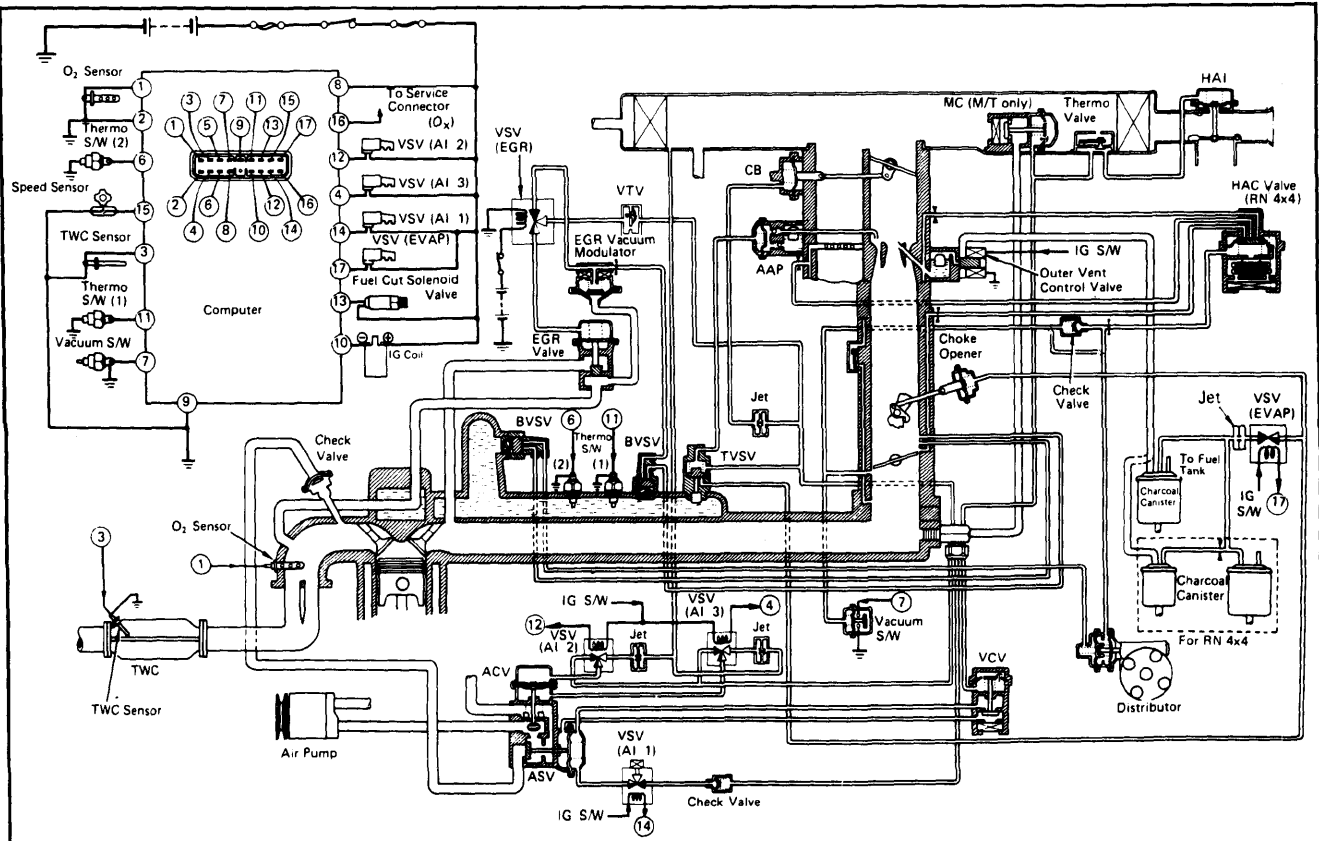

Fig. 6: Pickup California



TOYOTA VACUUM DIAGRAMS (Cont.)

Fig. 7: Pickup Federal Man. Trans.

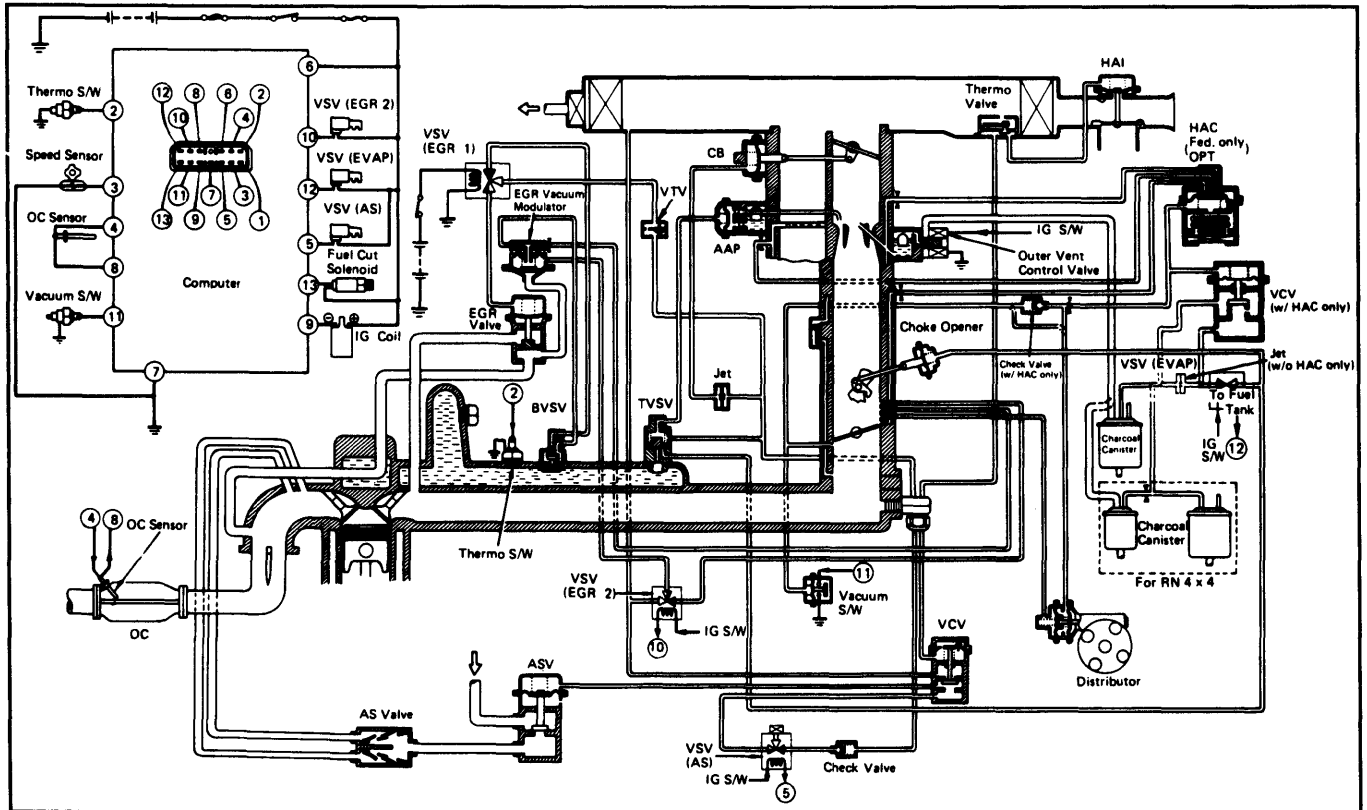
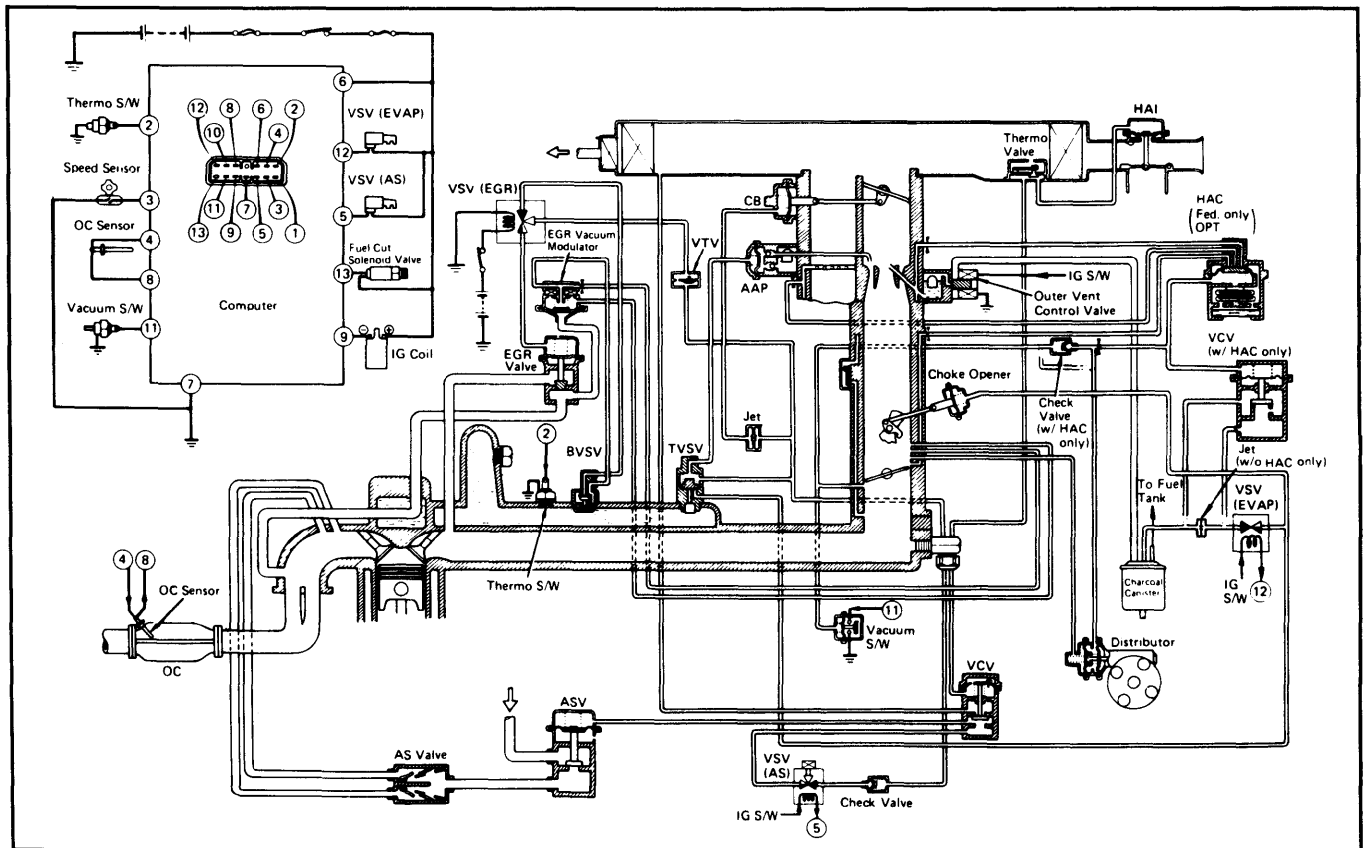

Fig. 8: Pickup Federal Auto Trans.



1982 Exhaust Emission Systems

TOYOTA VACUUM DIAGRAMS (Cont.)

Fig. 9: Starlet with High Altitude Compensation (HAC) System

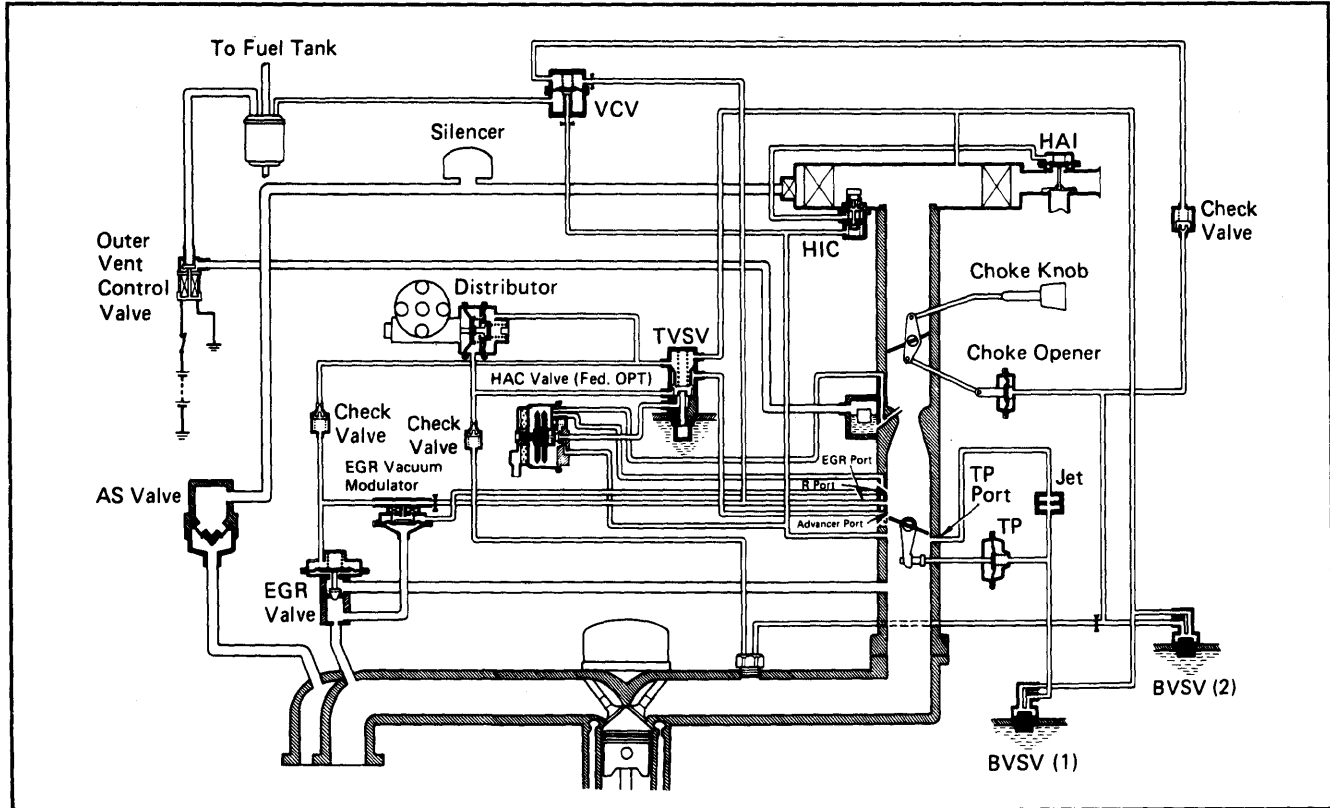
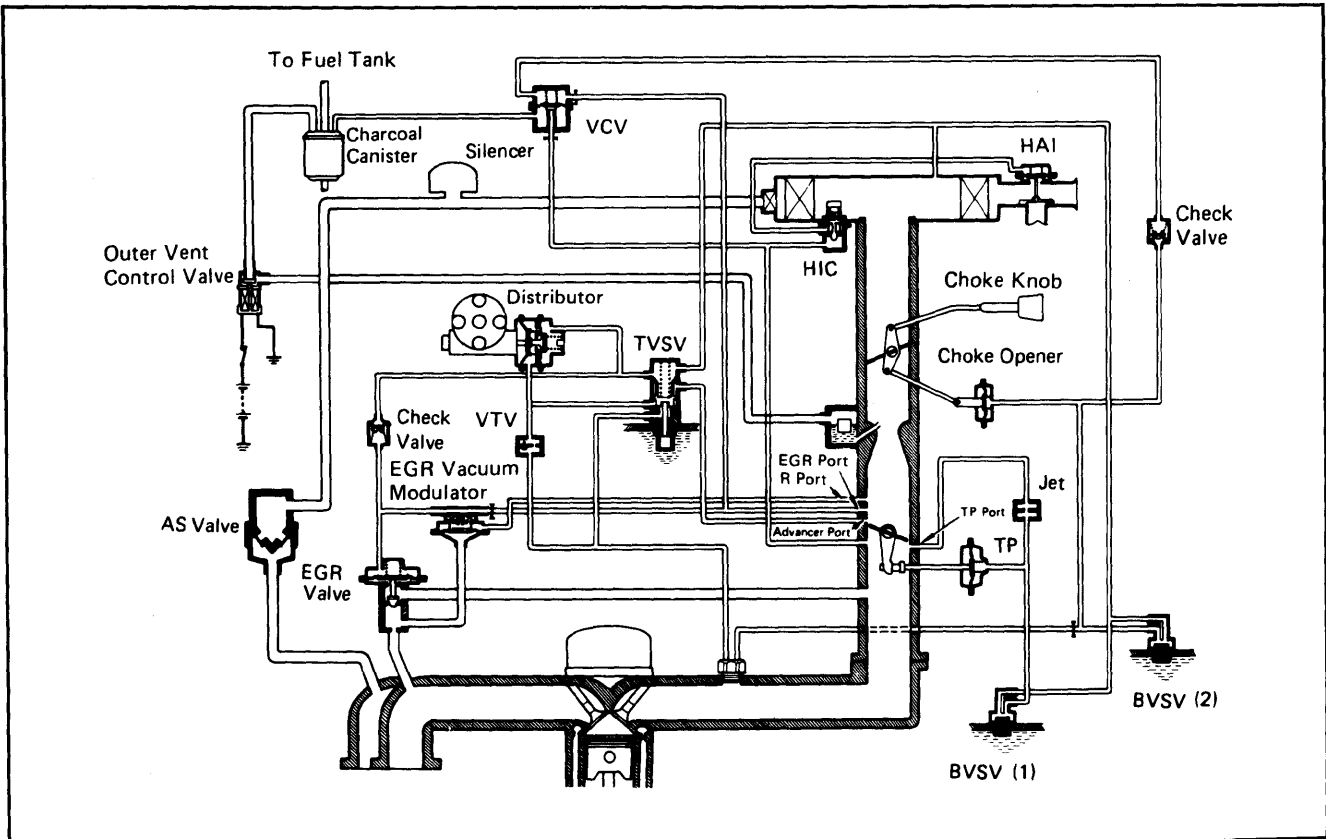

Fig. 10: Starlet without High Altitude Compensation (HAC) System



1982 Exhaust Emission Systems

TOYOTA VACUUM DIAGRAMS (Cont.)

Fig. 13: Tercel Federal

