

1982 Exhaust Emission Systems

RENAULT FAST IDLE DECELERATION SYSTEM

Le Car

DESCRIPTION

The fast idle system is designed to reduce HC emissions which result from the throttle closing on deceleration, creating an over-rich mixture. On Federal vehicles, the system consists of a throttle plate opener and a delay valve. California models use those components plus a vacuum reservoir, check valve, vacuum regulator, solenoid valve and electronic speed sensor.

OPERATION

FEDERAL MODELS

When deceleration starts, the high vacuum present at throttle opener port passes through delay valve and holds throttle plate opener so additional air passes through carburetor primary throat. The delay valve ensures a gradual return to idle as it vents vacuum slowly to atmosphere.

Fig. 1: Federal Le Car Fast Idle System

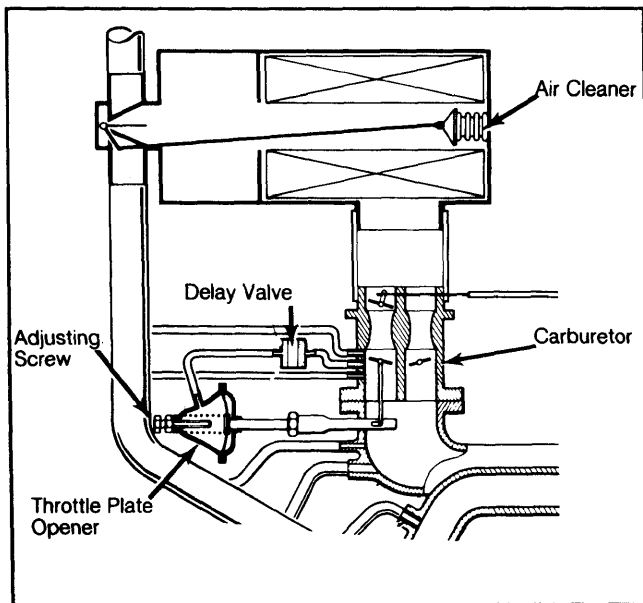

CALIFORNIA MODELS

One circuit of system is connected to vacuum at the throttle port, the other at intake manifold. When the throttle plate suddenly closes, creating more than 10.6 in. Hg, the check valve closes. Vacuum pulls the throttle opener and it holds the throttle plate open. Vacuum drops slowly as the delay valve bleeds it off.

When vacuum drops too low, the check valve opens. Intake manifold vacuum is applied and controlled by vacuum regulator at 6 in. Hg. This vacuum keeps the throttle plate positioner half-open. When vehicle speed drops below 17 mph, the speed sensor turns off the solenoid valve. Manifold vacuum is cut off and the throttle closes.

A separate dashpot (not vacuum controlled) keeps the throttle from closing completely for 2-4 seconds.

Fig. 2: Calif. Le Car Fast Idle System

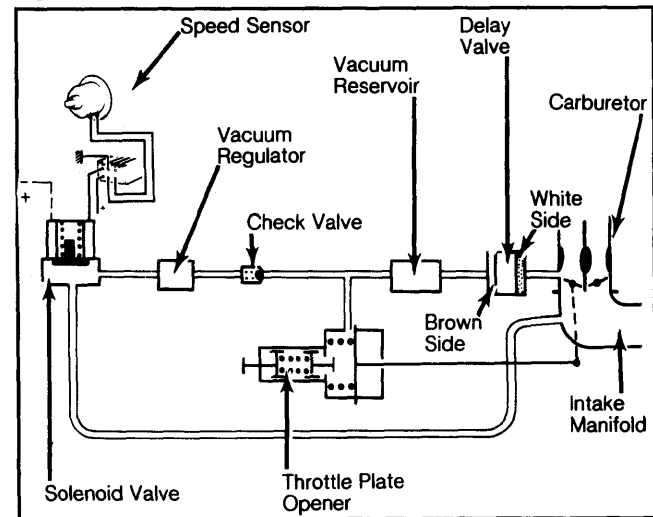

TESTING

FEDERAL MODELS

Connect intake manifold vacuum directly to throttle plate opener. Engine speed should stabilize at 1800-2000 RPM. Reconnect original vacuum hose, accelerate engine to 3500 RPM and release throttle slowly. Engine speed should slowly drop (3-5 seconds).

CALIFORNIA MODELS

Accelerate engine to 4000 RPM and release throttle. Engine speed should return to idle after 3-6 seconds. Drive vehicle at a speed over 25 MPH, then depress clutch. Engine speed should stabilize at 1400-1600 RPM until speed drops below 17 MPH.

ADJUSTMENT

FEDERAL MODELS

Using a hand vacuum pump, apply more than 4.5 in. Hg vacuum to throttle plate opener. Adjust screw on top of diaphragm to obtain 1800-2000 RPM.

CALIFORNIA MODELS

Ground fast idle solenoid wire (Green), or apply less than 6 in. Hg vacuum to throttle plate opener. Adjust idle speed with screw on opener to obtain 1400-1600 RPM.