

PEUGEOT DIESEL EXHAUST GAS RECIRCULATION

504 Diesel, 505 Diesel

DESCRIPTION

All Peugeot Diesel models are equipped with an exhaust gas recirculation system to reduce NOx emissions. A controlled amount of exhaust gas is introduced into intake manifold during certain engine loads. This lowers combustion temperatures and NOx formation.

The system consists of an engine speed sensor on the flywheel housing, 2 load sensors on the injection pump, 3 electrovalves, vacuum controlled throttle flap, 2-stage EGR valve, and electronic control box (ECB).

OPERATION

SYSTEM OPERATION

When the engine is idling below 1300 RPM, the speed sensor on the flywheel housing monitors engine RPM and relays this information to the ECB. No EGR occurs. With the engine running between 1300 RPM and full-throttle, there are 3 possible levels of EGR.

Under light loads, maximum EGR occurs. The swing arm on side of the injection pump uncovers both load sensors. The ECB opens all electrovalves. This applies vacuum to upper and lower chambers of EGR valve which opens to maximum position. Vacuum is also applied to throttle flap vacuum motor, causing throttle flap to close half-way.

Under medium loads, the amount of EGR becomes moderate. The swing arm covers lower load sensor and uncovers upper load sensor. This opens only the 2 electrovalves controlling upper and lower chambers of EGR valve. The throttle flap returns to a vertical or fully open position because its electrovalve is closed.

Under a high load, the amount of EGR is at a minimum. The swing arm covers upper and lower load sensors. The only electrovalve opening is the one controlling upper chamber of EGR valve. This opens EGR valve only half-way. The throttle flap remains open.

With engine under a full load, there is no EGR. The swing arm uncovers the lower load sensor and covers the upper load sensor. All 3 electrovalves are closed and the throttle flap is open.

SPEED SENSOR

The speed sensor mounts on the flywheel housing and monitors the rotation of 2 slots in the flywheel. It provides a signal to the ECB which permits EGR to only occur above 1300 RPM.

LOAD SENSORS

The 2 engine load sensors are located on the side of injection pump. When the throttle is opened, a swing arm passes over the sensors to provide 4 different sensor signals to the ECB. When the sensor is not covered by the swing arm, a 2 volt signal is sent to the ECB. When the sensor is covered, a 5 volt signal is sent.

Fig. 1: Peugeot Diesel EGR System Vacuum & Wiring Diagram

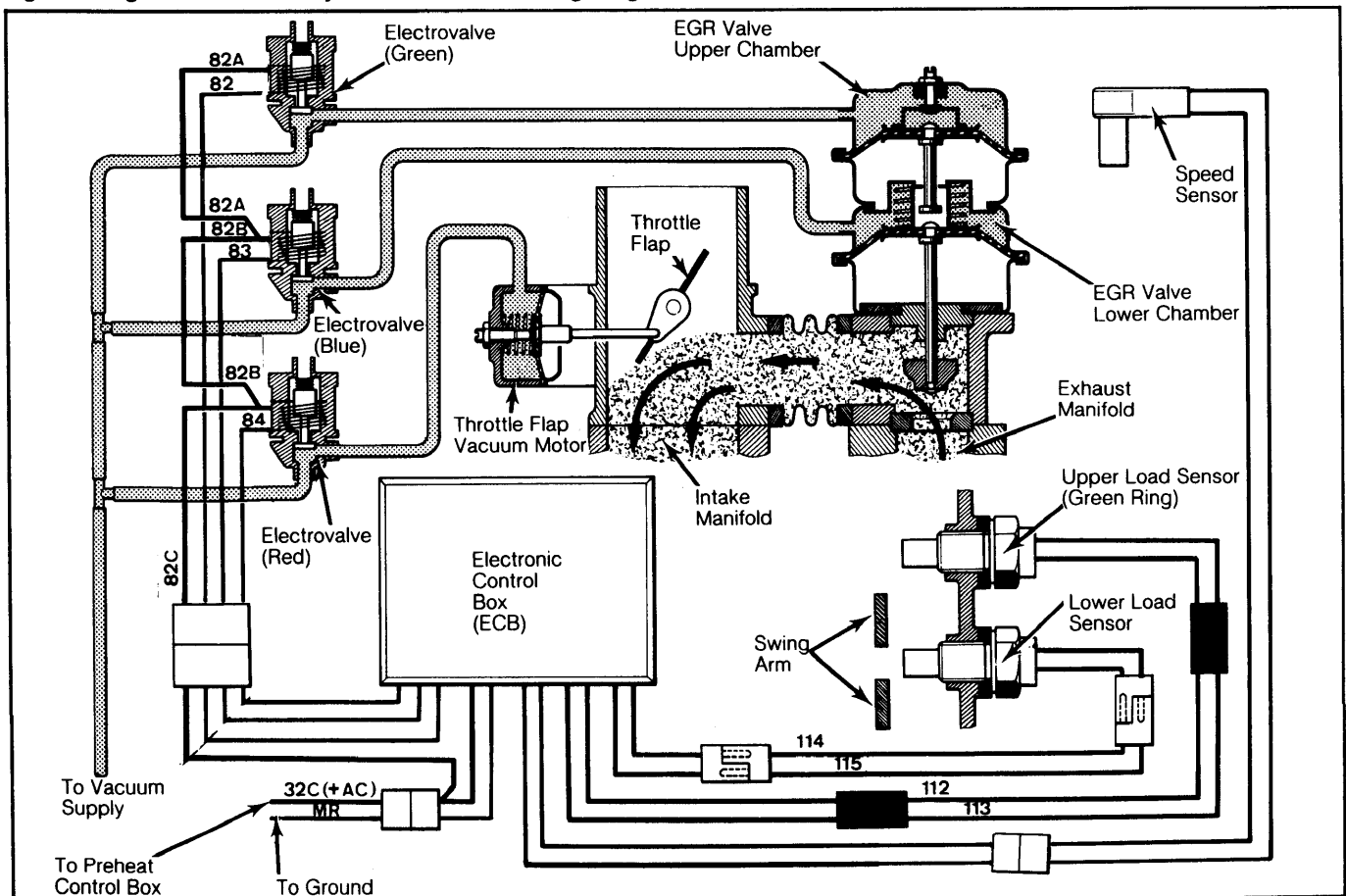

1982 Exhaust Emission Systems

PEUGEOT DIESEL EXHAUST GAS RECIRCULATION (Cont.)

ELECTROVALVES

The 3 electrovalves control the 4 levels of EGR valve and the third valve controls the throttle flap vacuum motor. When no current is applied to the valves, they are open to atmosphere. With current applied, the valves route vacuum from the vacuum pump to the EGR valve and the throttle flap vacuum motor.

EGR VALVE

When no vacuum is applied to EGR valve, it is held closed by spring pressure. When vacuum is applied to upper chamber, valve opens half-way. With vacuum applied to both chambers, EGR valve is fully opened.

THROTTLE FLAP

The throttle flap is used to raise intake manifold vacuum. When vacuum is applied to the throttle flap vacuum motor, the throttle flap is moved to a half-open position. With no vacuum, the flap is fully open and does not affect intake vacuum.

TESTING

EGR SYSTEM CHECK

CAUTION: Do not attempt to adjust the link-rod between output lever and swing arm on injection pump. If link-rod setting is changed, it will be necessary to replace complete pump.

1) An improperly functioning EGR system results in heavy exhaust smoke and poor engine performance. If symptoms are not found when engine is cold, warm up engine until fan engages. This is to locate the components which malfunction only when hot.

2) To check system, remove bracket holding electrovalves and ECB. This exposes ECB electrical connectors. Disconnect connector between ECB and engine speed sensor. Start engine.

3) If symptoms disappear, EGR system is at fault. Check adjustment of each load sensor. See *Load Sensor Adjustment*. If symptoms are still present, perform the following tests.

ELECTRICAL CHECK

NOTE: Tests are made with ignition switch in the "ON" position. Wires are identified by numbers painted on the wire insulation.

Electronic Control Box Power

1) Disconnect connector between ECB and preheat control box. Connect voltmeter to ground and wire 32C of connector half leading to preheat control box.

2) Voltage reading should be equal to battery voltage. If no voltage or a large difference in voltage, check wire 32C for shorts. Also check fuse box for blown fuse.

Load Sensors

1) Disconnect connector between load sensor and ECB. Connect voltmeter to ground and female terminal (wire 113 or 115) or connector half leading to ECB.

Fig. 2: Diesel EGR Electrical Components & Wires

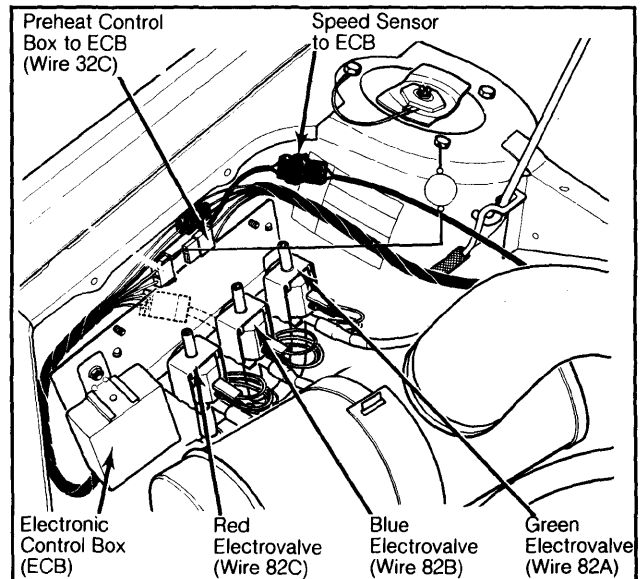

2) Voltage should be 8 volts or more. If less than 8 volts, check wire 113 or 115 for shorts. Partially connect connector pins between load sensor and ECB.

NOTE: Load sensor connectors are next to injection pump and are covered by a piece of tubing.

3) Expose connector pins, but do not break electrical contact. Connect voltmeter to ground and to exposed connector pin on wire 112 or 114. Move swing arm until load sensor is covered by target area. See Fig. 3.

4) Voltmeter should read 5 volts or more. Move swing arm until load sensor is uncovered by target area. Voltmeter should read 2 volts or less.

5) If the voltages in step 4) are zero or about equal, connect voltmeter to ground and to exposed connector pin on wire 113 or 115.

6) Voltage reading should be 8 volts or more. If not, replace load sensor and adjust relative position of sensor to target area. See *Load Sensor Adjustment*.

Speed Sensor

Disconnect connector between speed sensor and ECB. Connect leads of ohmmeter to connector terminals of speed sensor. Resistance should be 40-60 ohms. If not, replace speed sensor.

Electrovalves

1) Partially disconnect top wires (82A, 82B, and 82C) to each electrovalve without breaking electrical contact. Connect voltmeter to ground and to exposed terminal.

2) Voltage for each wire should be equal to battery voltage. If not, check problem wire for shorts. Disconnect bottom wire (82, 83, or 84) to electrovalve being tested. Connect a jumper wire in place of it on electrovalve.

3) Ground other end of jumper wire. There should be a "clicking" sound from electrovalve. If not, disconnect other wire from electrovalve.

4) Connect leads of ohmmeter to terminals on electrovalve. Resistance should be about 40 ohms. If resistance is infinity or close to it, replace electrovalve.

PEUGEOT DIESEL EXHAUST GAS RECIRCULATION (Cont.)

VACUUM CHECK

EGR Throttle Flap Housing

1) Disconnect Red-ringed hose from inner electrovalve. Connect hose to a vacuum pump. Apply 2.4 in. Hg. Throttle flap control rod should begin to move.

2) Apply vacuum until 12.6 in. Hg is reached. Throttle flap control rod should now be at end of travel. If flap does not operate properly, replace entire assembly with a new EGR throttle flap housing.

3) With vacuum pump still connected to Red-ringed hose, remove air intake hose from throttle flap housing. Apply 12.6 in. Hg of vacuum until throttle flap reaches maximum travel.

4) Measure distance between throttle flap and throttle flap housing. Distance must be greater than 0.18" (4.5 mm). If not, replace entire assembly with a new EGR throttle flap housing.

EGR Valve

1) To test upper chamber, disconnect Green-ringed hose from outer electrovalve and connect it to a vacuum pump. Apply 2.4 in. Hg of vacuum.

2) The diaphragm should start to move. Apply vacuum until 11.8 in. Hg is reached. Diaphragm should now have reached end of travel.

3) If diaphragm does not operate properly, remove, clean, and reinstall EGR valve. Repeat steps 1) and 2). If diaphragm still does not function properly, replace EGR valve.

4) Repeat steps 1) through 3) on lower chamber, but substitute Blue-ringed hose from middle electrovalve in place of Green-ringed hose.

ADJUSTMENTS

LOAD SENSOR

1) Position swing arm as shown in Fig. 3. The target area must be positioned in front of threaded holes of bracket as shown. Using a depth gauge, measure distance "X" as shown in Fig. 3.

2) Distance "X" must be 1.14-1.15" (28.9-29.1 mm). If not, remove load sensor and adjust distance "X" using shims.

NOTE: Upper load sensor has a Green ring or a Green electrical connector and must be mounted in bracket hole with letter "V" stamped next to it.

SPEED SENSOR

Loosen clamp holding speed sensor in place on top of flywheel housing. Push sensor down until it contacts flywheel. Pull sensor back up a maximum of 0.020" (0.5 mm). Tighten sensor clamp.

Fig. 3: EGR Load Sensor Adjustment

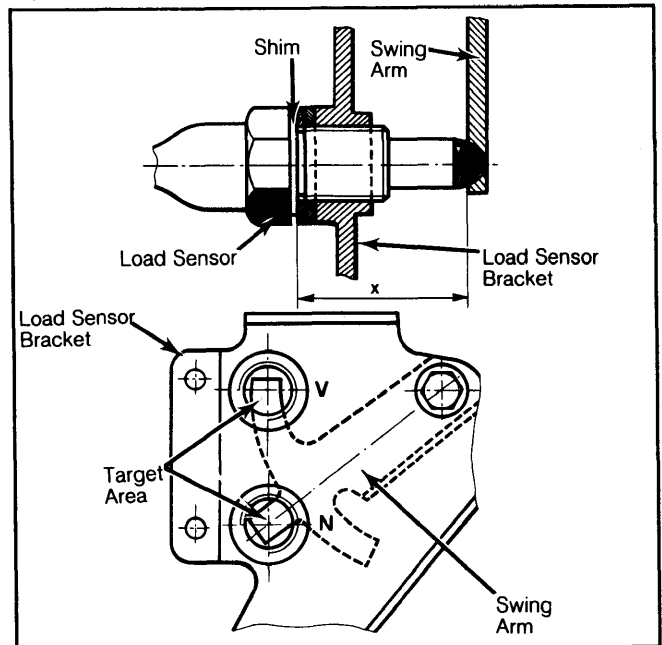

Position swing arm as shown.