

MAZDA RX7 DECELERATION CONTROL SYSTEM

DESCRIPTION

The Deceleration system is designed to maintain a balanced air/fuel mixture during deceleration. System consists of 2 anti-afterburn valves, shutter solenoid valve, coasting/shutter valve, throttle sensor, dashpot (manual transmission models) and connecting hoses and wiring.

OPERATION

The No. 2 anti-afterburn valve (located below air cleaner) is actuated by the shutter solenoid valve to supply additional air from air cleaner to intake manifold at initial deceleration to prevent afterburning of fuel. The coasting/shutter valve work together to supply air (coasting valve) and fuel (shutter valve) during deceleration to prevent back firing.

TESTING

NO. 1 ANTI-AFTERBURN VALVE

1) Warm engine to normal operating temperature and ensure engine operates smoothly at idle. Stop engine. Disconnect air pump-to-air control hose at air pump.

2) Disconnect electrical connectors from relief solenoid valve (Blue color dot) and switching solenoid valve (Gray color dot). Start engine and run at idle. Place finger over air pump-to-air control hose.

3) Air should not be drawn in and idle speed should not change. Disconnect vacuum hose "A"; speed should return to normal idle. If valve does not respond as outlined, replace No. 1 anti-afterburn valve.

Fig. 1: Testing No. 1 Anti-Afterburn Valve

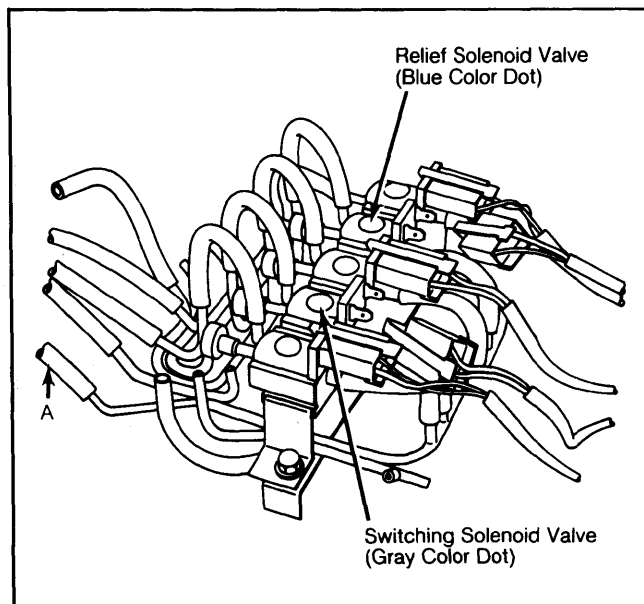

NOTE: Before replacing No. 1 anti-afterburn valve, check auxiliary control unit as outlined in "Mazda RX7 Auxiliary Control Device," article in this section. Also check relief solenoid and switching solenoid valves as described in

"Mazda RX7 Air Injection System," article in this section.

NO. 2 ANTI-AFTERBURN VALVE

1) Warm engine to normal operating temperature. Disconnect No. 2 anti-afterburn valve-to-air cleaner hose at air cleaner. Place finger over hose and ensure air is not drawn into hose.

2) Disconnect vacuum sensing hose from No. 2 anti-afterburn valve. Air should not be drawn into hose. Connect vacuum sensing hose to valve; air should be drawn into anti-afterburn valve-to-air cleaner hose for 3 seconds.

3) If air is drawn for more than 3 seconds or no air is drawn, replace No. 2 anti-afterburn valve.

THROTTLE SENSOR

1) Warm engine to normal operating temperature. Stop engine. Connect tachometer to engine. Disconnect throttle sensor electrical connector, located on right side of engine (Black/Yellow and Green/Black wires).

2) Using 2 voltmeters, connect positive lead of one voltmeter to Light Green/Yellow wire terminal of throttle sensor check connector. Connect positive lead of other voltmeter to Green/Yellow wire terminal of throttle sensor connector. Connect negative terminals of both voltmeters to good ground. See Fig. 2.

Fig. 2: Testing Throttle Sensor

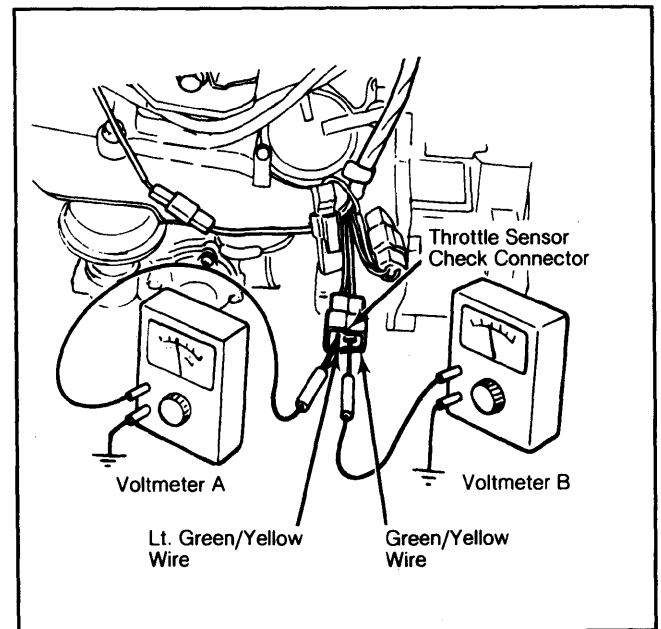

3) Start engine and run at 3000 RPM. Quickly decelerate engine. Current should flow to both terminals simultaneously when engine speed is 1000-1200 RPM. If current does not flow to both terminals at the same time, remove cap from throttle sensor adjusting screw and adjust throttle sensor.

4) Adjust timing of current flow to voltmeter "A" in Fig. 2 by turning throttle sensor adjusting screw. Turning screw in causes current to flow to Light Green/Yellow wire at lower engine speed. After adjustment, install cap on throttle sensor adjusting screw and retest throttle sensor.

1982 Exhaust Emission Systems

MAZDA RX7 DECELERATION CONTROL SYSTEM (Cont.)

SHUTTER SOLENOID VALVE

1) Disconnect vacuum sensing tubes from shutter solenoid valve (Yellow color dot). Blow through solenoid valve through vacuum hose "B" shown in Fig. 3; air should go through valve and escape at front port.

2) Disconnect electrical connector and apply battery power to terminals on solenoid valve. Blow through hose again; air should escape through air filter at rear of solenoid valve. If valve does not respond as outlined, perform signal check.

Fig. 3: Testing Shutter Solenoid Valve

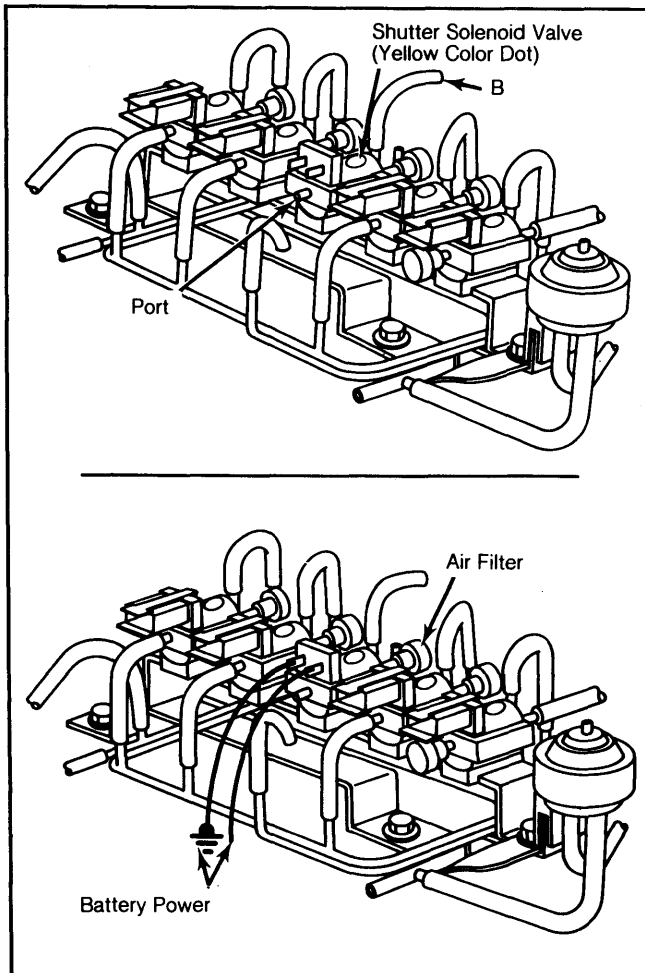

SHUTTER SOLENOID VALVE SIGNAL CHECK

1) Warm engine to normal operating temperature. Stop engine. Connect tachometer to engine. Connect voltmeter to terminals of shutter solenoid valve electrical connector without disconnecting connector.

2) Disconnect throttle sensor electrical connector (Black/Yellow and Green/Black wires). Shift automatic transmission into "P" or "N". Start engine and run at idle.

3) Current should flow to shutter solenoid valve terminals. Disconnect electrical connector from throttle sensor; current should stop flowing to solenoid valve. Shift automatic transmission into "D". Connect throttle sensor connector disconnected in step 1); current should flow to solenoid valve terminals.

Fig. 4: Testing Shutter Solenoid Valve Signal

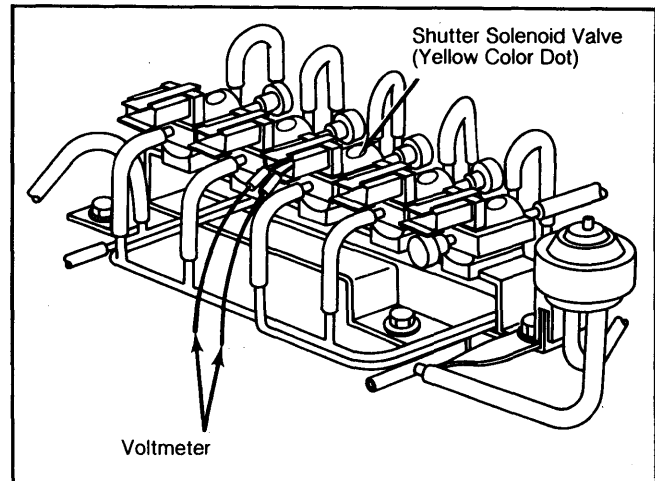

4) On automatic transmissions, shift into "P" or "N". Current should flow to solenoid valve terminal at any engine speed. If solenoid valve does not respond as described, replace shutter solenoid valve.

NOTE: Before replacing shutter solenoid valve, check auxiliary control unit as outlined in "Mazda RX7 Auxiliary Control Device," article in this section. Also check relief solenoid and switching solenoid valves as described in "Mazda RX7 Air Injection System," article in this section.

COASTING/SHUTTER VALVE

1) Warm engine to normal operating temperature. Stop engine. Disconnect air cleaner-to-coasting valve hose at air cleaner. Start engine and run at idle. Place finger over disconnected hose; air should not be drawn into hose.

2) Disconnect electrical connector from shutter solenoid valve. Air should be drawn into disconnected hose and idle should fluctuate. At the same time, the coasting valve rod should be pulled into coasting valve about .4" (10mm), opening shutter valve. If coasting/shutter valve does not respond as outlined, replace coasting/shutter valve.

DASHPOT (MAN. TRANS. ONLY)

1) Remove air cleaner. Checking all vacuum sensing tubes for proper condition and connections. Check that dashpot rod does not bind throttle lever movement.

2) Quickly operate throttle lever fully and make sure dashpot rod extends quickly. Release throttle lever and make sure that throttle lever returns slowly to idle position after it has touched dashpot rod.

3) Connect tachometer to engine. Start engine and warm to operating temperature. Ensure engine idle speed is adjusted to specification. Operate throttle lever until it is away from dashpot rod.

4) Slowly decrease engine speed and check speed at which throttle lever just touches dashpot rod. It should be 3800-4200 RPM. If not, loosen lock nut and turn dashpot diaphragm to adjust engine speed.