

## MAZDA RX7 AIR INJECTION SYSTEM

### DESCRIPTION

This system controls CO, HC and NO<sub>x</sub> emissions by injecting secondary air into the exhaust system to cause further burning of exhaust gases. System consists of an air pump, 2 check valves, an air control valve, a relief solenoid valve, a switching solenoid valve, a heat hazard sensor, a monolith converter and a pellet converter.

Air is drawn from the clean side of the air cleaner by the air pump and directed to the air control valve under pressure. From the air control valve, secondary air is directed (by the switching solenoid valve) "downstream" to the pellet converter or "upstream" to the exhaust port.

The secondary air system contains 2 check valves to prevent exhaust gas from leaking back into the air pump. The switching solenoid valve directs secondary air through the air control valve "downstream" and/or "upstream", based upon engine temperature, manifold vacuum and engine speed. The relief solenoid valve controls the amount of air injected according to intake manifold vacuum.

Under normal operating conditions, part of the secondary air supplied by the air pump is directed back to the air cleaner. The heat hazard sensor lights an exhaust temperature warning light on the instrument panel if exhaust temperatures become excessive.

**Fig. 1: Mazda RX7 Air Injection System**

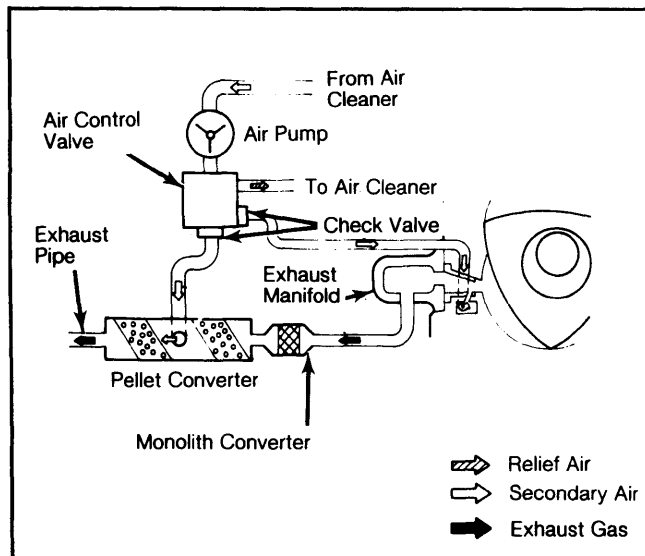

### TESTING

#### AIR PUMP

1) With engine at normal operating temperature, inspect all hose connections for leaks. Check for pump noise and belt tension.

2) Stop engine and disconnect air line at air control valve. Connect hose to a pressure gauge. Connect tachometer to engine.

3) Start engine and run at idle speed. Gauge should register more than 1.64 psi (.12 kg/cm<sup>2</sup>) with engine at 800 RPM. If pump pressure is below specification, replace air pump.

### CHECK VALVES

1) Check valves are located at the air control valve exhaust port outlet and in the air supply line between the air control valve and pellet converter.

2) To test exhaust port check valve, detach air pump-to-air control valve hose at air control valve. To test converter check valve, detach air control valve-to-pellet converter hose at air control valve. Test each valve separately using the following procedure:

3) With engine at normal operating temperature, connect tachometer to engine. Detach hose for valve to be tested. Start engine and increase engine speed to 1500 RPM. Watch for exhaust leak. If leak exists, replace check valve being tested.

### AIR CONTROL VALVE

1) After ensuring air pump and all hoses are correct, check carburetor and air control valve attaching nuts for tightness. Warm engine to normal operating temperature.

2) Stop engine and connect a tachometer. Disconnect air cleaner-to-air control valve hose at air cleaner. Disconnect both vacuum hoses from relief solenoid valve (Blue color dot).

3) Using rubber hose, by-pass relief solenoid valve by connecting vacuum lines on each side of relief valve together. See Fig. 2. This will cause manifold vacuum to be routed directly to air control valve.

4) Start engine and run at idle. Place finger over air cleaner-to-air control valve hose and check that air is not escaping through hose. Disconnect rubber hose used to by-pass relief solenoid valve; air should escape at air cleaner-to-air control valve hose.

5) Reconnect by-pass hose at relief solenoid valve. Using throttle, set engine speed at 2500 RPM. Disconnect vacuum sensing tube from switching solenoid valve (Gray color dot).

6) Place finger over air cleaner-to-air control valve hose; air should escape through hose. Reconnect switching solenoid valve vacuum tube; air should not escape at air cleaner-to-air control valve hose. If air control valve does not respond as described, replace air control valve.

**Fig 2: Hose Arrangement for Checking Air Control Valve Operation**

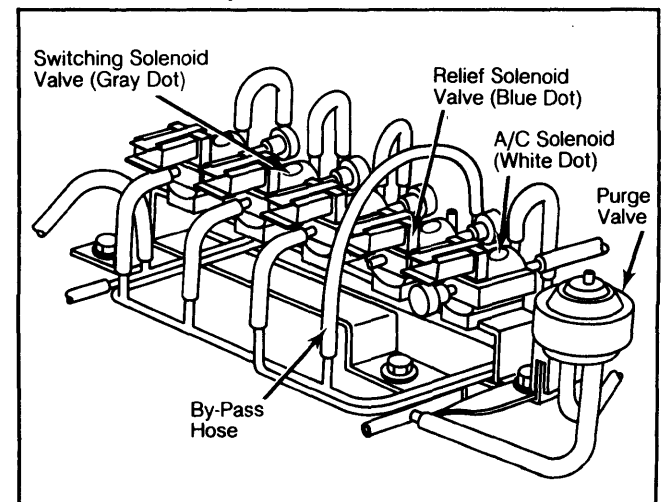

# 1982 Exhaust Emission Systems

## MAZDA RX7 AIR INJECTION SYSTEM (Cont.)

### RELIEF SOLENOID VALVE

1) Disconnect vacuum sensing tubes from relief solenoid valve and vacuum pipe. Blow through solenoid valve from vacuum sensing tube "B" in Fig. 3. Air should pass through valve and escape from front port.

2) Disconnect electrical connector from relief solenoid valve and connect battery power to solenoid terminals. Blow through vacuum hose again. Air should pass through valve and escape through air filter. If valve does not respond as described, replace relief solenoid valve.

Fig. 3: Testing Relief Solenoid Valve

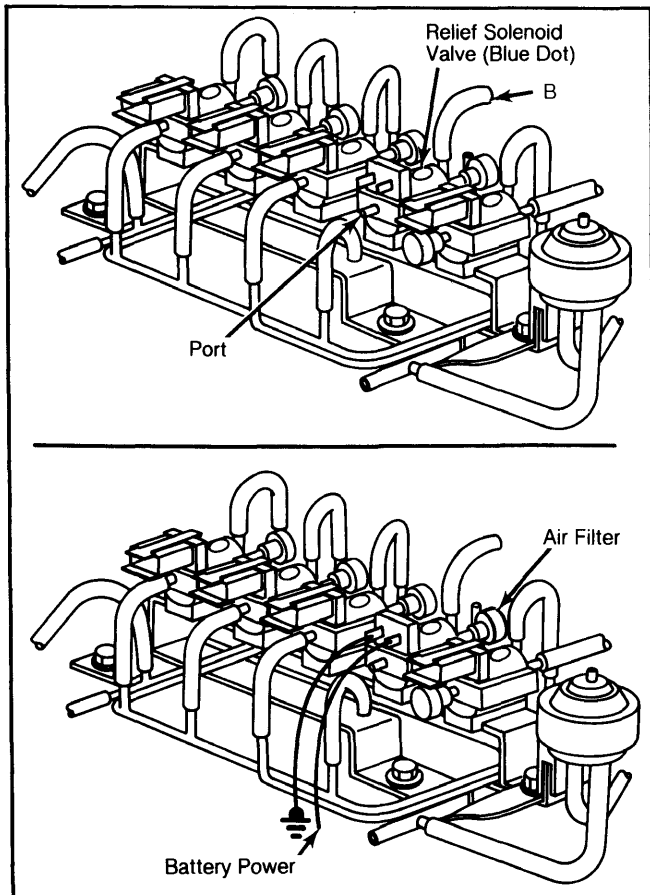

### RELIEF SOLENOID VALVE SIGNAL CHECK

1) Warm engine to normal operating temperature. Connect tachometer to engine. Connect voltmeter to relief solenoid valve connector terminals.

2) Disconnect connector from throttle sensor and connect a jumper wire between terminals "A" and "C" of connector. See Fig. 4. Start engine and increase engine speed.

3) Current should flow to relief solenoid valve connector when engine speed is 3600-4400 RPM. Set engine speed at 2000 RPM. Disconnect No. 2 water temperature switch (located on radiator) electrical connector.

4) Slowly decrease engine speed from 2000 RPM and watch voltmeter. Current should stop flowing to relief solenoid valve when engine speed is 1000-1200 RPM. Decrease engine speed to idle.

5) Remove jumper wire from throttle sensor connector and reconnect throttle sensor connector. Slowly increase engine speed from idle (with throttle) and watch voltmeter. Current should not flow to relief solenoid valve at any speed.

6) Quickly accelerate engine; current should flow to valve. Reconnect No. 2 water temperature switch connector. Disconnect electrical connector from No. 1 water temperature switch (located behind alternator) and connect a jumper wire between both terminals of connector.

7) Fully pull out choke knob; current should flow to relief solenoid valve. Push choke knob back in. Remove passenger seat and fold back carpeting to expose heat hazard sensor wiring.

8) Disconnect heat hazard sensor connector; current should flow to relief solenoid valve at any engine speed. Remove jumper wire from No. 1 water switch and reconnect connector. Reconnect heat hazard sensor. If relief solenoid valve does not operate as outlined, check heat hazard sensor and retest relief solenoid valve.

Fig. 4: Testing Relief Solenoid Valve Signal

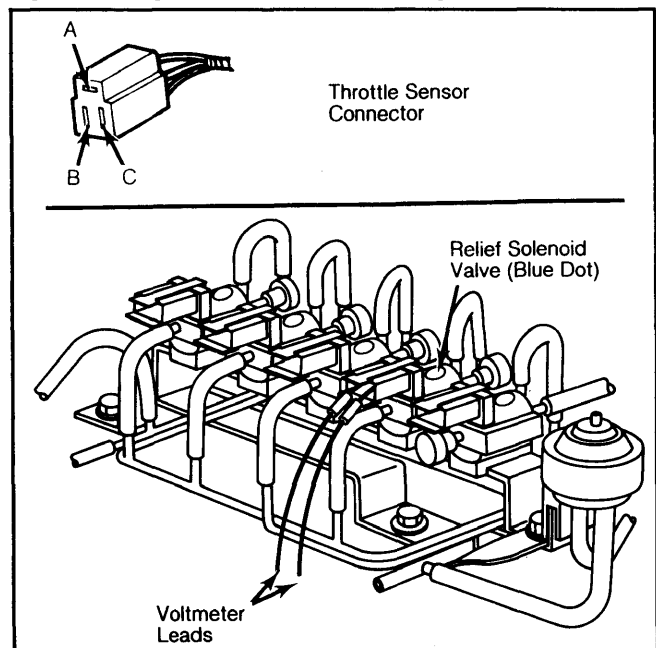

### SWITCHING SOLENOID VALVE

1) Disconnect vacuum sensing tubes from switching solenoid valve and vacuum pipe. Blow through switching valve from vacuum sensing tube "B" in Fig. 5. Air should pass through valve and escape from front port.

2) Disconnect electrical connector from switching valve and connect battery power to terminals on valve. Blow through hose again; air should pass through valve and escape through filter at rear of valve. If switching valve does not respond as described, replace switching solenoid valve.

### SWITCHING SOLENOID VALVE SIGNAL CHECK

1) Warm engine to normal operating temperature. Connect tachometer to engine. Connect voltmeter to switching solenoid valve connector terminals.

## MAZDA RX7 AIR INJECTION SYSTEM (Cont.)

2) Disconnect throttle sensor connector and connect a jumper wire between terminals "A" and "C" of connector. Start engine and run at 2000 RPM. Slowly decrease engine speed and watch voltmeter.

3) Current should stop flowing to switching valve terminal when engine speed is 1000-1200 RPM. Disconnect No. 1 water temperature switch (located behind alternator) and connect a jumper wire between both terminals in connector.

4) Fully pull out choke knob; current should not flow to switching valve terminal. Push choke knob back in. Remove jumper wire from throttle sensor connector and reconnect connector.

5) Slowly increase engine speed from idle (with throttle) and watch voltmeter. Current should not flow to switching valve at any speed. Quickly accelerate engine; current should flow to switching valve. If switching valve does not respond as outlined, replace switching solenoid valve.

**Fig. 5: Testing Switching Solenoid Valve**

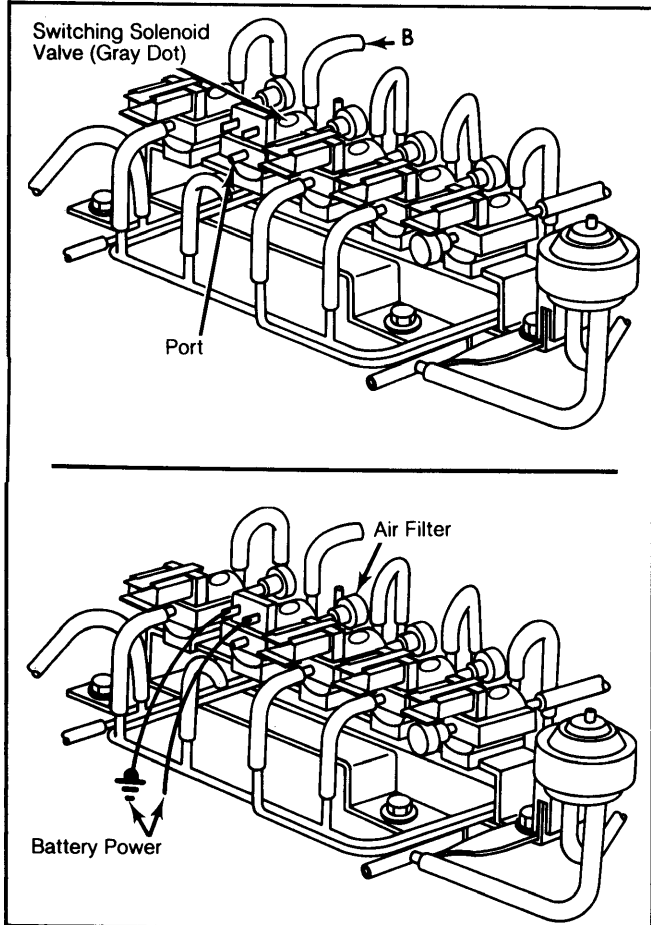

### HEAT HAZARD SENSOR

1) Turn ignition on; "Overheat Exh. System" warning light should glow. Start engine and warning light should go out. Remove passenger seat, fold back carpeting, and disconnect heat hazard sensor; warning light should glow.

2) If warning light does not respond as outlined, remove and test sensor. Wrap sensor and a thermometer in aluminum foil (electrical connector must be exposed for access). Place sensor and thermometer (wrapped in aluminum foil) in container filled with oil, place a second thermometer in container of oil. See Fig. 6.

3) Connect a battery and test lamp to sensor connector. Test lamp should glow. Gradually heat oil. Test lamp should go out when temperature inside aluminum foil is 248-284°F (120-140°C). If sensor does not respond as outlined, replace heat hazard sensor.

**NOTE:** Do not heat oil above 302°F (150°C).

**Fig. 6: Testing Heat Hazard Sensor**

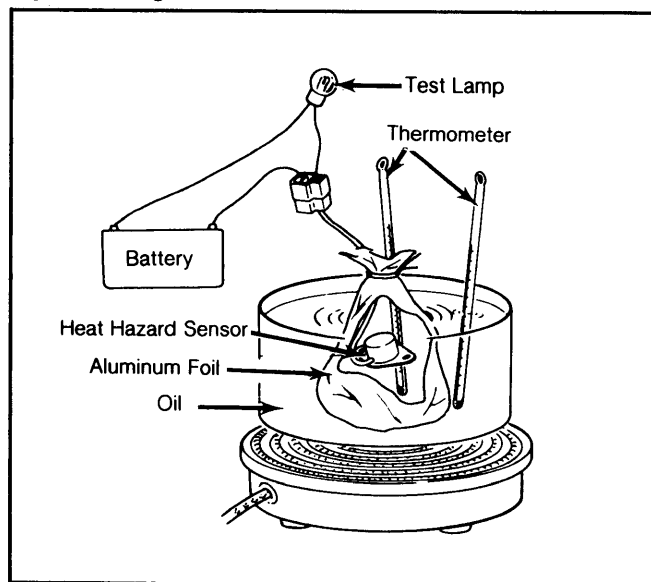

**NOTE:** Before replacing air control valve, switching solenoid valve or relief solenoid valve, check auxiliary control unit, No. 2 water temperature switch, choke switch and choke relay as described in "Mazda RX7 Auxiliary Control Device," article in this section. Also check throttle sensor as described in "Mazda RX7 Deceleration Control System," article in this section.