

# 1982 Exhaust Emission System

## DATSUN VACUUM DIAGRAMS

Fig. 1: Datsun Maxima Diesel Vacuum Diagram

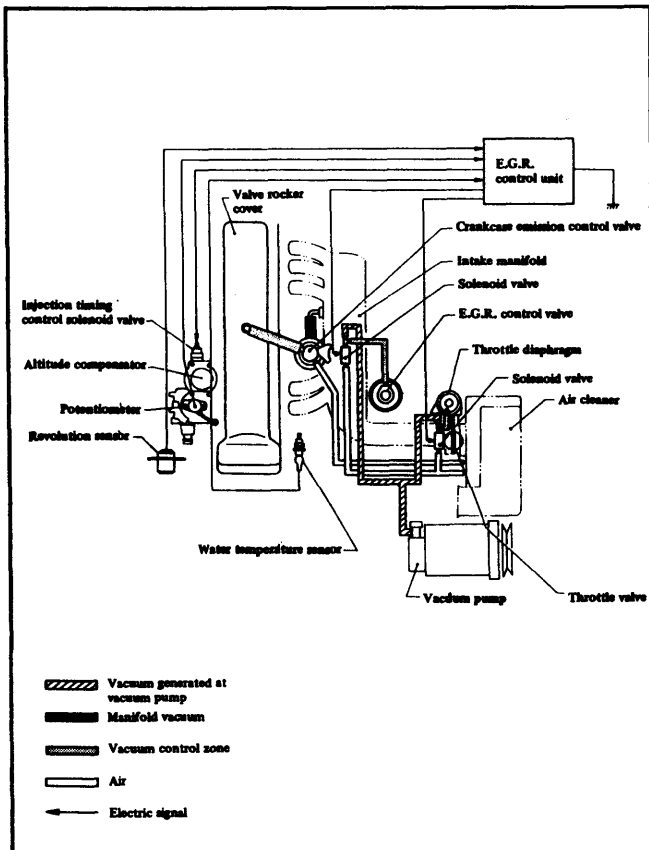


Fig. 3: Datsun Pickup Vacuum Diagram (California)

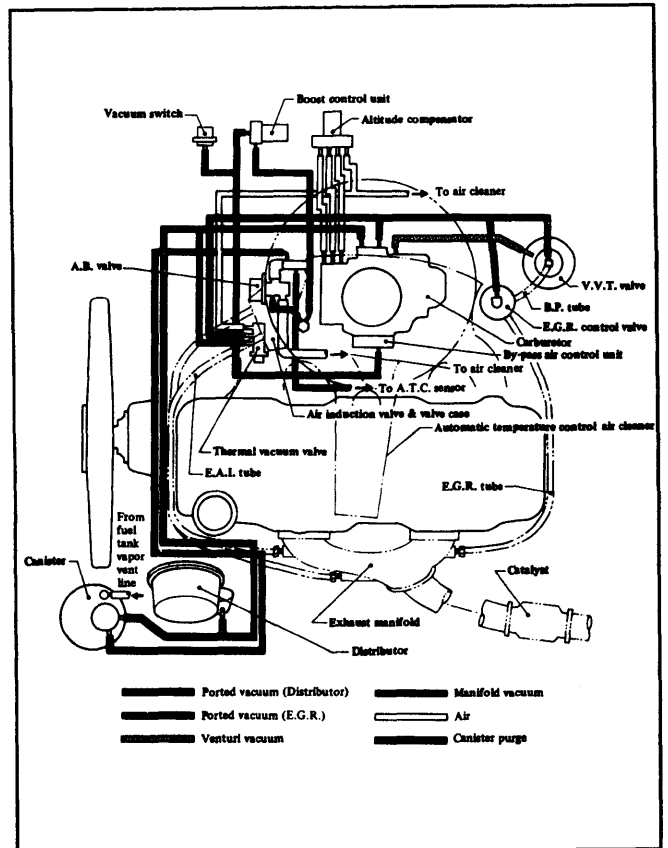


Fig. 2: Datsun Maxima Gasoline Vacuum Diagram

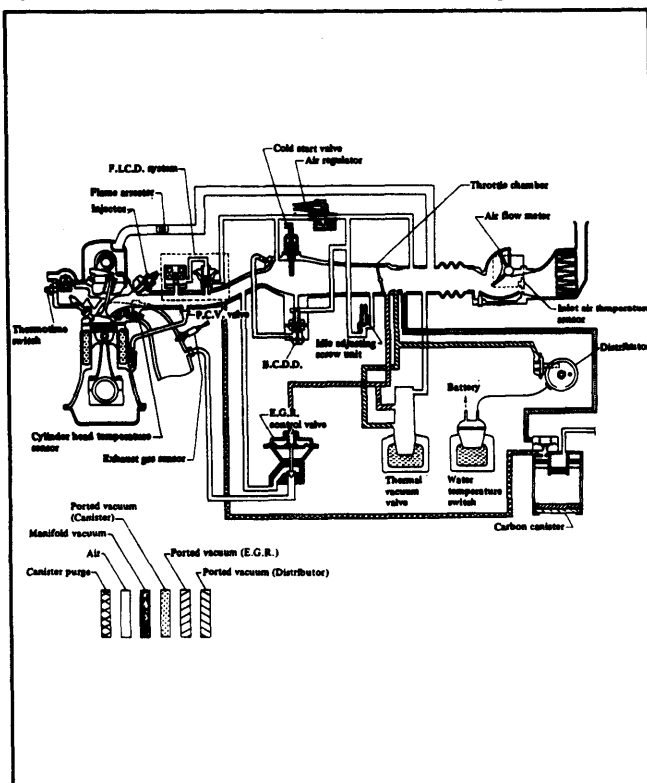
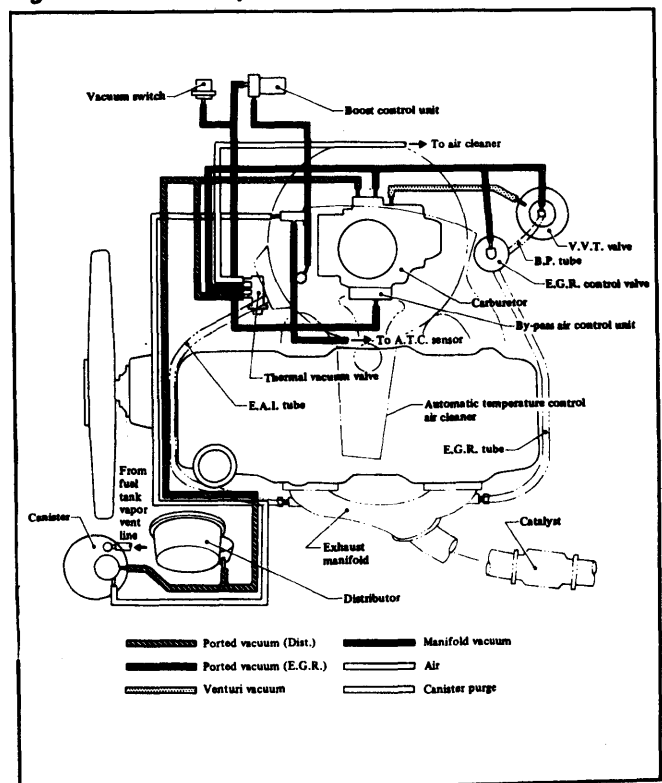


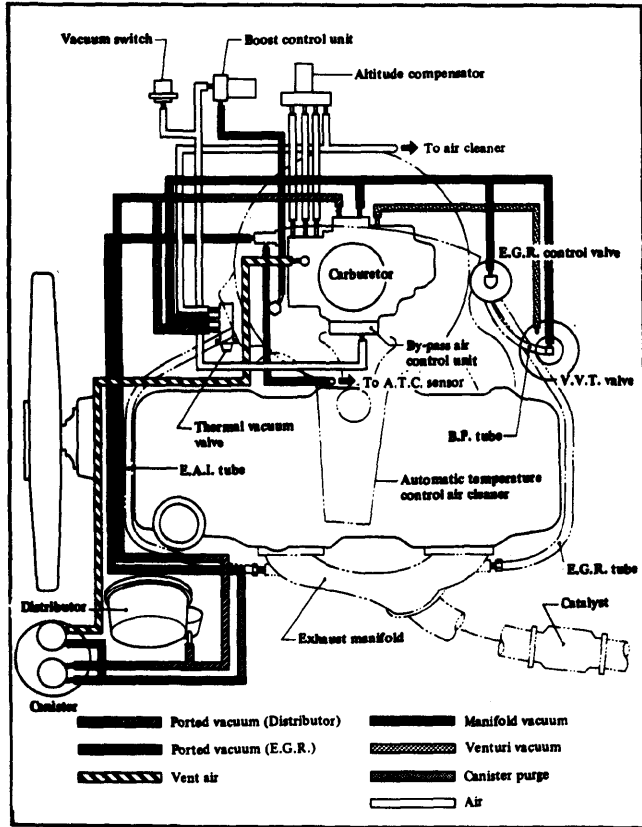
Fig. 4: Datsun Pickup Vacuum Diagram (Federal)



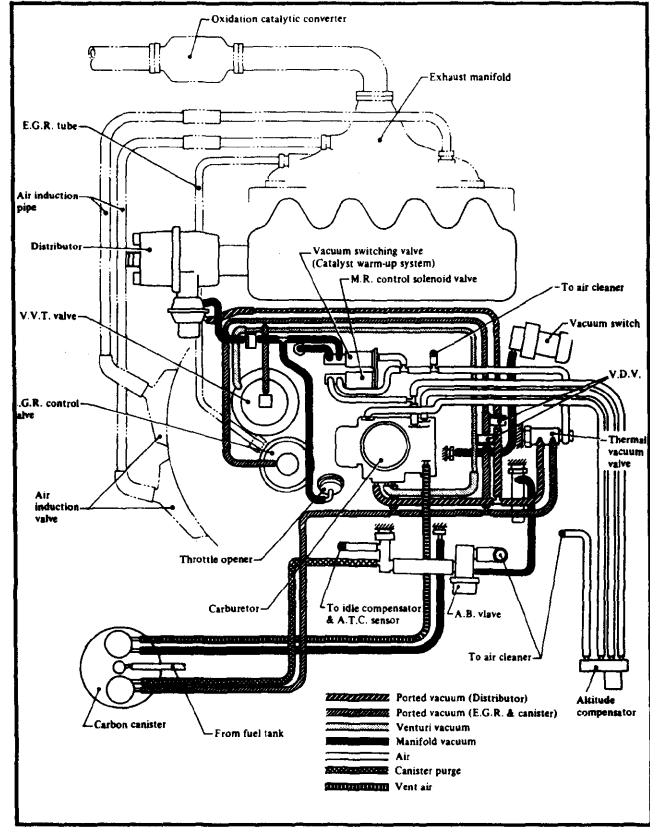
# 1982 Exhaust Emission Systems

## DATSUN VACUUM DIAGRAMS

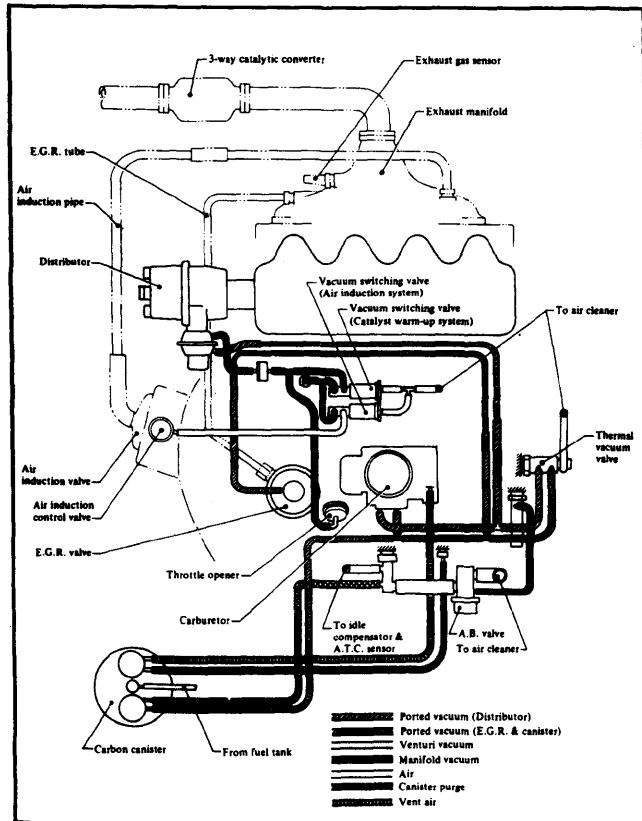
**Fig. 5: Datsun Pickup Vacuum Diagram (High Altitude)**



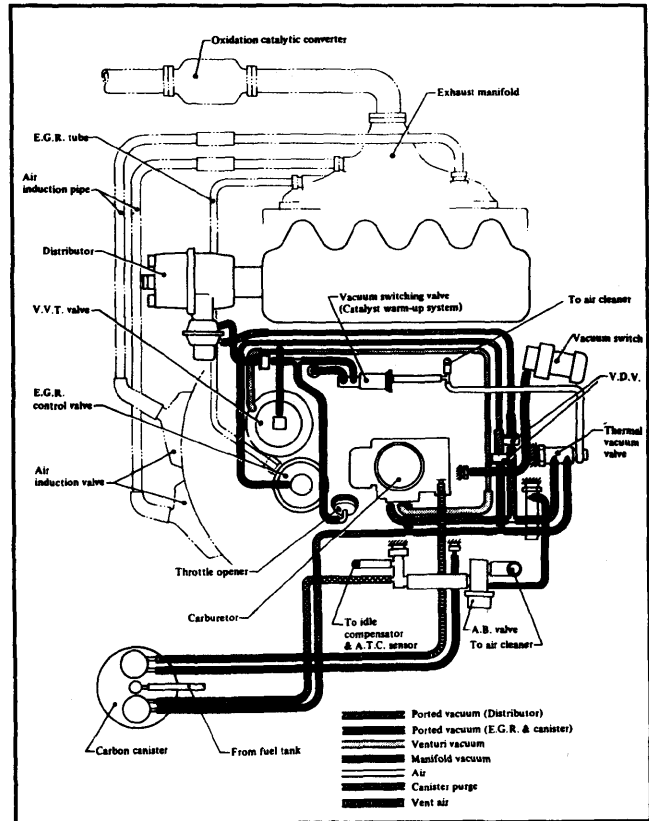
**Fig. 7: Datsun Sentra Exc. M.P.G. & 310 (California)**



**Fig. 6: Datsun Sentra M.P.G. Vacuum Diagram**

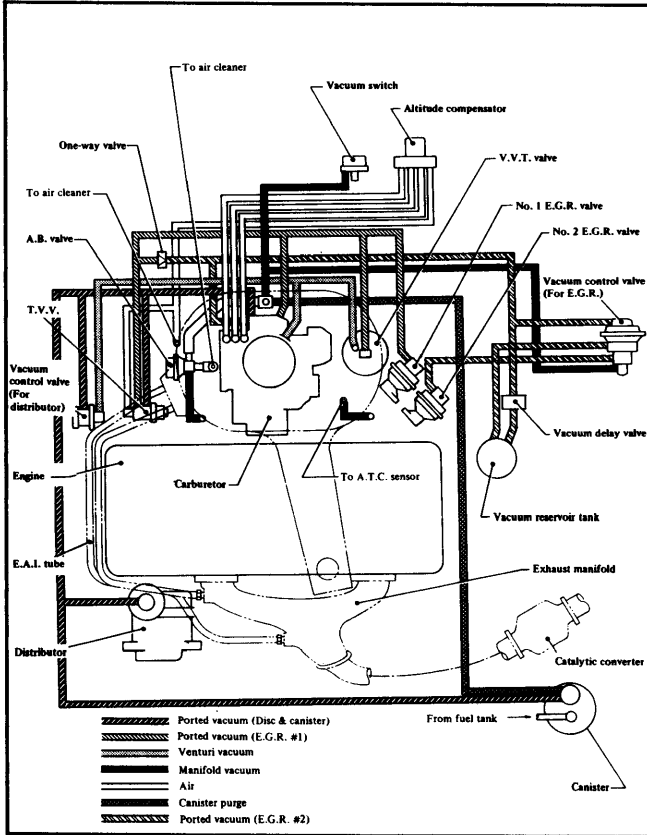


**Fig. 8: Datsun Sentra Exc. M.P.G. & 310 (Federal)**

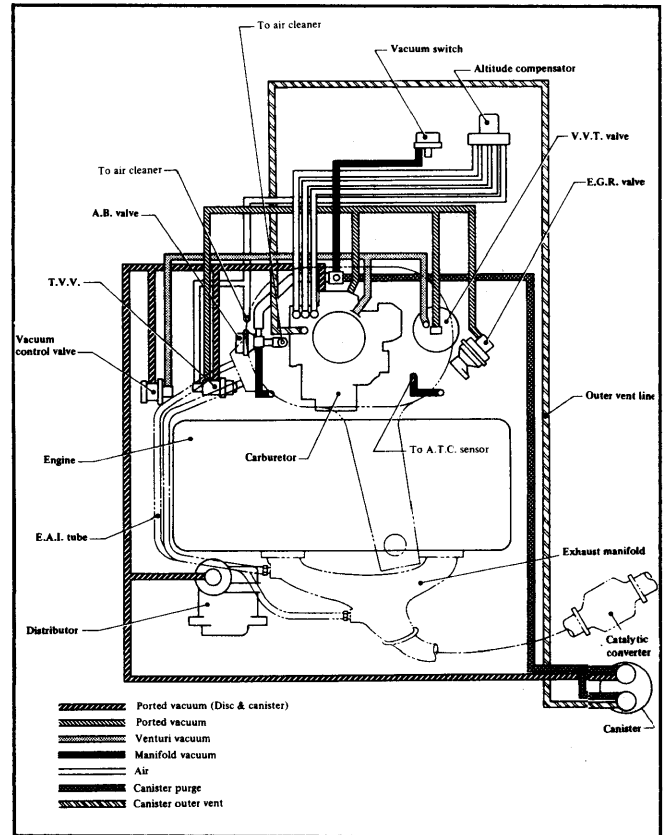


## DATSUN VACUUM DIAGRAMS (Cont.)

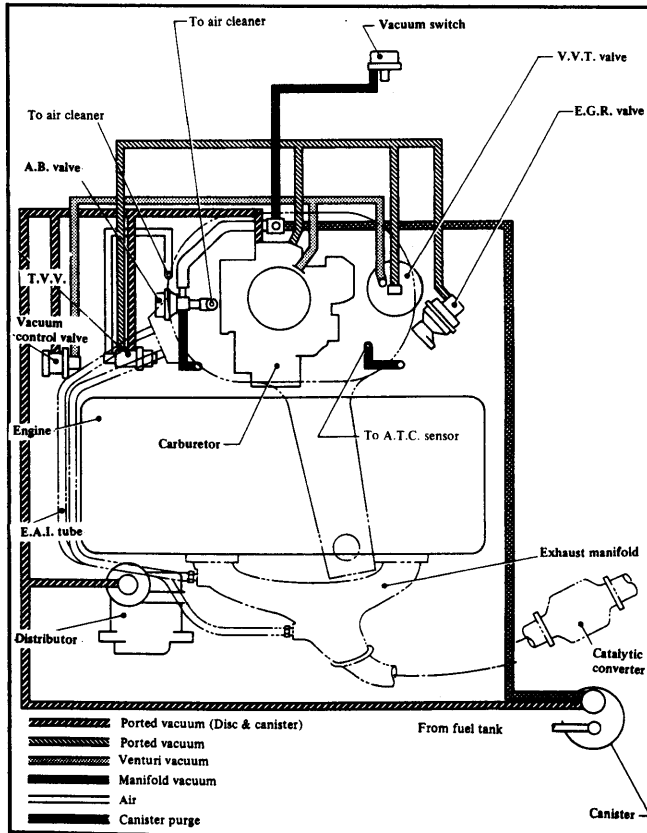
**Fig. 9: Datsun Stanza Vacuum Diagram (California)**



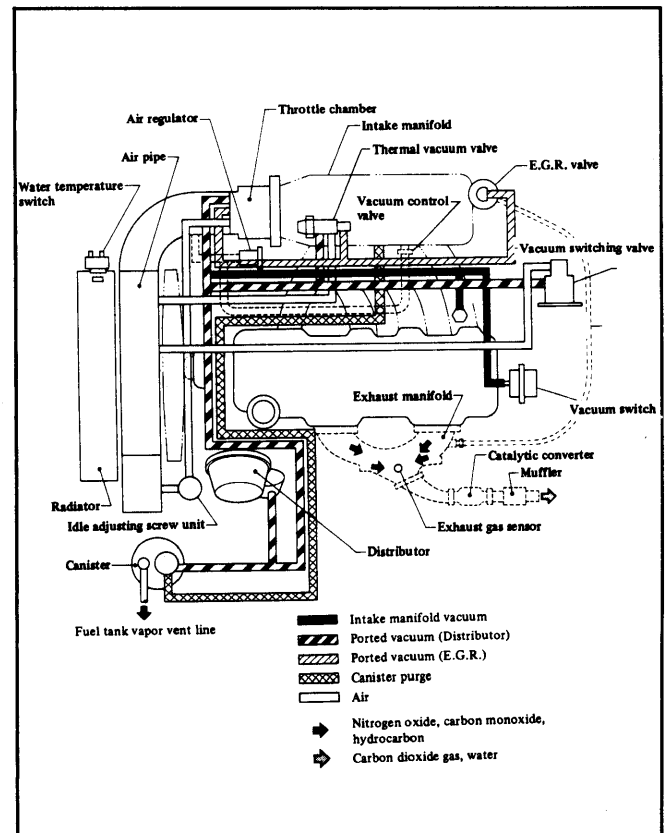
**Fig. 11: Datsun Stanza Vacuum Diagram (High Altitude)**



**Fig. 10: Datsun Stanza Vacuum Diagram (Federal)**



**Fig. 12: Datsun 200SX Vacuum Diagram**



# 1982 Exhaust Emission Systems

## DATSUN VACUUM DIAGRAMS (Cont.)

Fig. 13: Datsun 210 Vacuum Diagram (California)

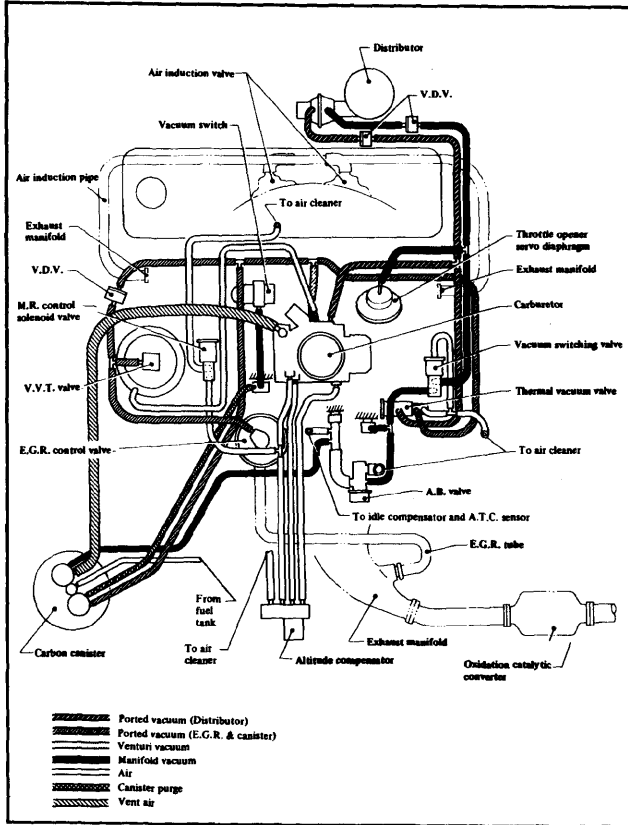


Fig. 15: Datsun 280ZX Vacuum Diagram

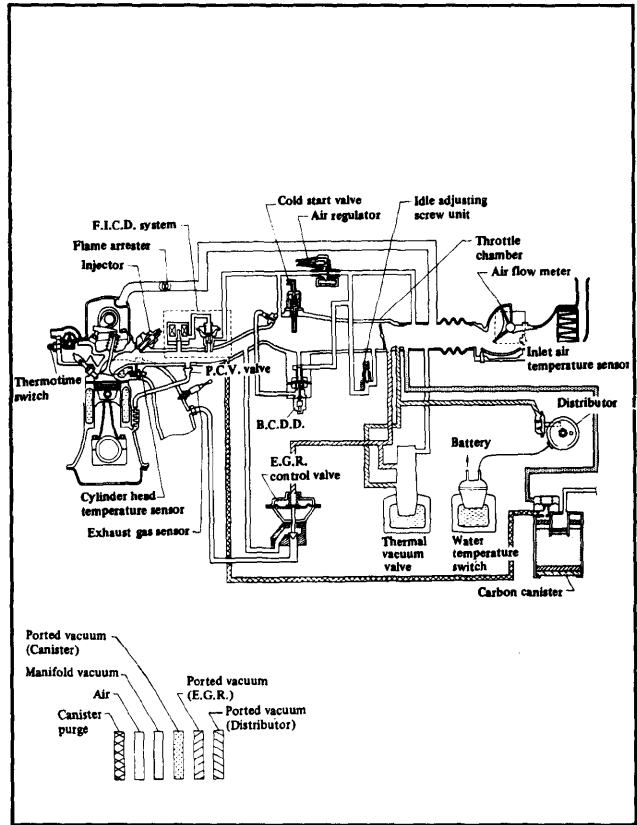


Fig. 14: Datsun 210 Vacuum Diagram (Federal)

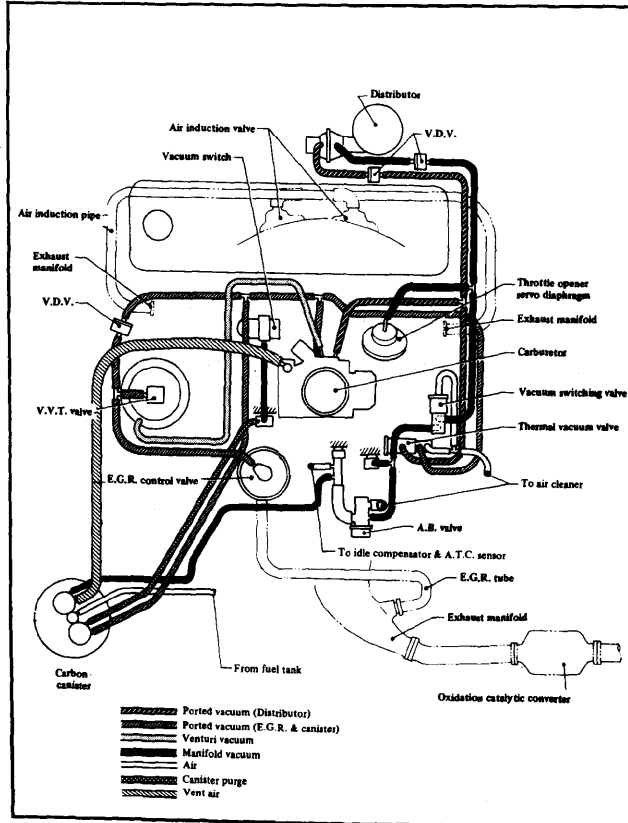


Fig. 16: Datsun 280ZX Turbo Vacuum Diagram

