

1982 Electric Fuel Pumps

TOYOTA ELECTRIC FUEL PUMPS

Cressida & Supra

DESCRIPTION

The fuel pump is located at the left rear of the vehicle on Cressida models and right rear on Supra models.

Internal components include a rotor, check valve, relief valve, orifice and silencer. See Fig. 1. If electric pump becomes defective, it must be replaced as the internal components are not serviceable.

Fig. 1: Sectional View of Electric Fuel Pump

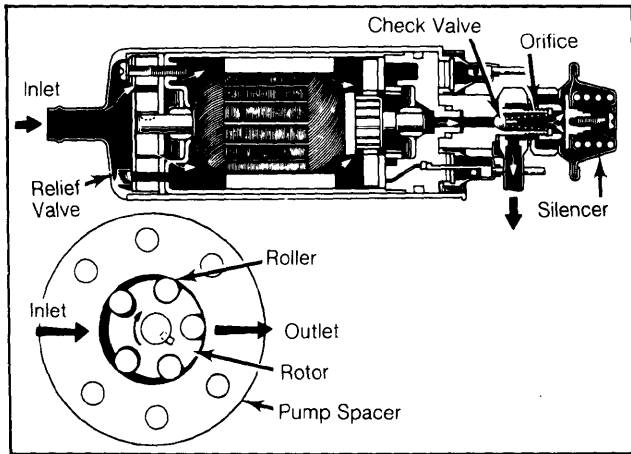

TESTING

PUMP OPERATION CHECK

1) Turn ignition switch "ON". Short both terminals of fuel pump check connector. See Fig. 2. Check for pressure in hose to cold start injector. At this time you will hear fuel return noise from pressure regulator.

Fig. 2: Check Connection Location

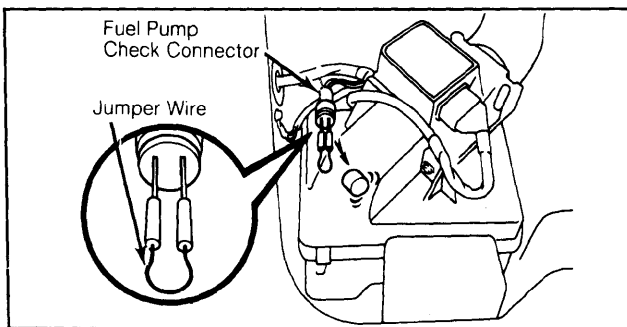

2) If there was no pressure in hose to cold start injector, check the following parts: Fusible link, 15 amp fuse, circuit opening relay, wiring connections and fuel pump pressure.

PUMP PRESSURE CHECK

1) Disconnect negative battery cable and wiring connector from the cold start injector. Place a container or shop towel under front end of delivery pipe.

2) Slowly loosen the union bolt of the cold start injector hose and remove the bolt and 2 gaskets from the delivery pipe. Drain fuel in delivery pipe.

3) Install fuel pressure gauge as shown in Fig. 3. Wipe off any spilled fuel and reconnect battery cable. Start engine.

Fig. 3: Fuel Pressure Gauge Installation

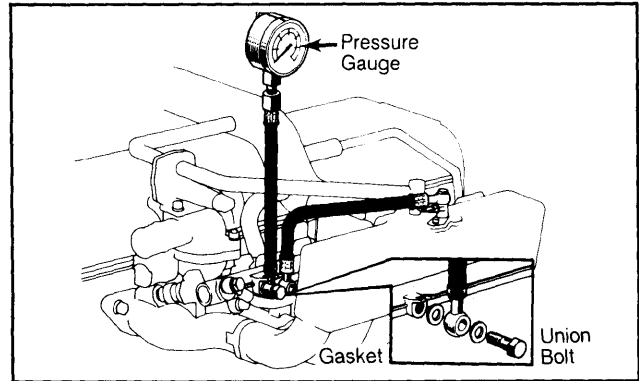

4) Disconnect and plug vacuum sensing hose from the pressure regulator. With engine idling, check that fuel pressure is 33-38 psi (2.3-2.7 kg/cm²).

5) If pressure is high, replace pressure regulator. If pressure is low, check fuel hoses and connections, fuel pump, filter and pressure regulator for leaks.

6) Reconnect vacuum sensing hose to pressure regulator. With engine idling, check that fuel pressure is 28-33 psi (2.0-2.3 kg/cm²). If pressure is high, replace pressure regulator.

7) Turn ignition switch "OFF". If pressure drops quickly, check fuel pump, pressure regulator and/or injectors. Disconnect negative battery cable. Carefully remove pressure gauge. Using new gaskets, reinstall removed parts.

Fig. 4: Cressida Fuel Pump Control System Circuit

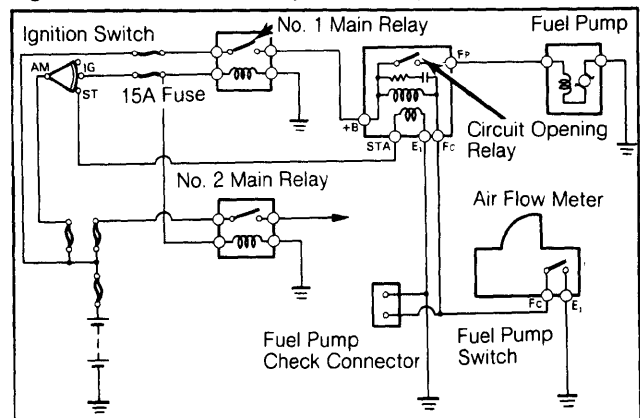

Fig. 5: Supra Fuel Pump Control System Circuit

