

MERCEDES-BENZ DIESEL

300 SD, 300 TD

DESCRIPTION

The diesel turbocharged engine (617.95) is basically the same design as the naturally aspirated diesel engine. See Fig. 1. Installation of the Garrett turbocharger produced an increase to 110 SAE net brake horsepower at 4200 RPM.

Fig. 1: Cutaway View of Mercedes-Benz Turbocharged Diesel Engine

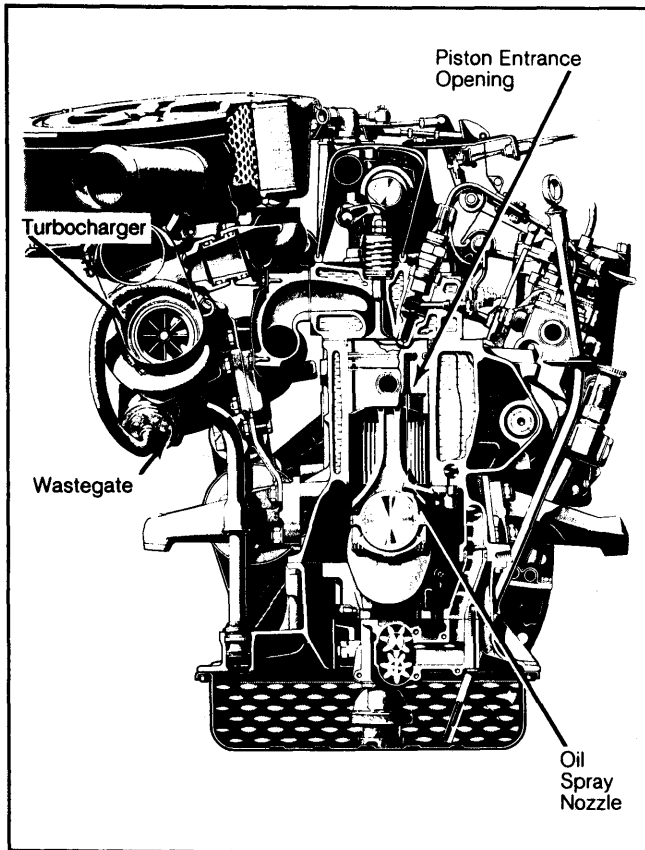

This increased power output required modifications of engine and vehicle components, including redesign of the crankcase, pistons, valve train, lubrication system, cooling system and fuel injection system.

The turbocharger delivers pre-compressed air to the engine, providing a higher air charge in the cylinders and creating higher pressures and temperatures in the combustion chambers.

The system includes a turbocharger which consists of a turbine, compressor and a wastegate that prevents excessive boost pressures from damaging the engine. See Fig. 2.

The turbocharger's turbine wheel and compressor wheel are mounted on a common shaft and turn at the same speed. The turbocharger is mounted between the exhaust manifold and the exhaust pipe and is connected directly to the engine for lubrication and cooling. The wastegate is attached to the turbine housing. Should its boost pressure control valve malfunction, an engine overload protection system will prevent engine damage.

Fig. 2: Cutaway View of Garrett Turbocharger

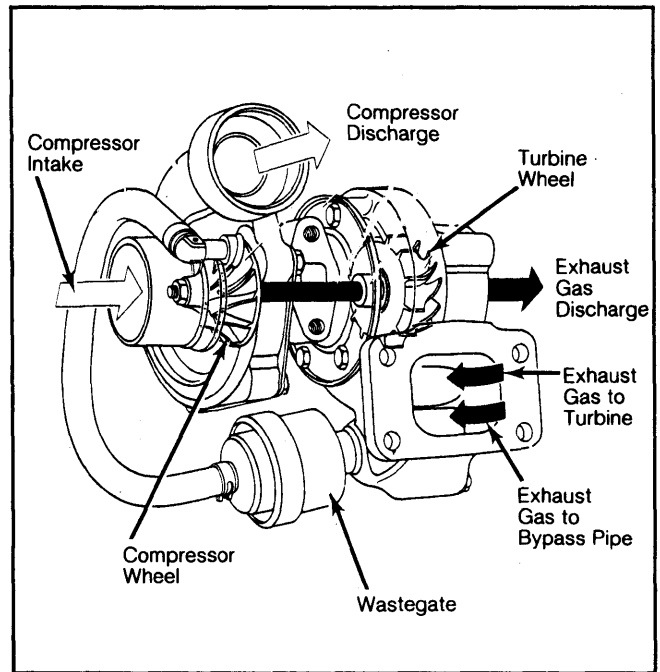

OPERATION

Exhaust gases leaving the cylinders flow through the exhaust manifold directly into the turbocharger's turbine housing. The force of the gases turns the turbine wheel, which in turn spins the compressor wheel at the same speed. Turbine and compressor wheel speeds can reach up to 100,000 RPM. See Figs. 2 and 3.

Fig. 3: Airflow Pattern with Garrett Turbocharger

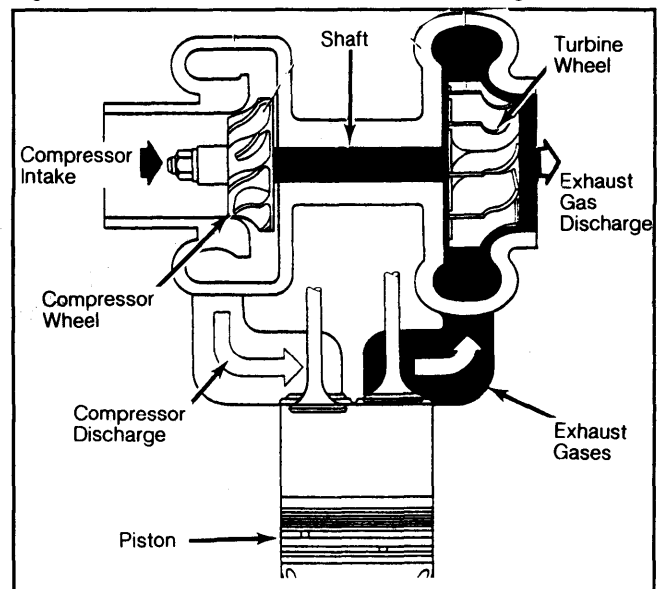

The fresh air drawn in by the compressor wheel is compressed and delivered to the combustion chamber above the pistons. At idle speed, the engine operates like any other. However, with increasing load and engine speed, exhaust gases are expelled with increasing

1982 Turbocharging Systems

MERCEDES-BENZ DIESEL (Cont.)

velocity. This causes the turbine wheel to turn faster, increasing boost pressure at the compressor wheel. Boost pressure is routed to the intake manifold and to individual cylinders, completing the cycle.

The aneroid compensator on top of the fuel injection pump automatically adjusts fuel quantity injected into cylinders depending on existing boost pressure or atmospheric pressure in intake manifold. Therefore, correct air-fuel relationship is maintained at all times.

Fig. 4: Cutaway View of Wastegate Valve

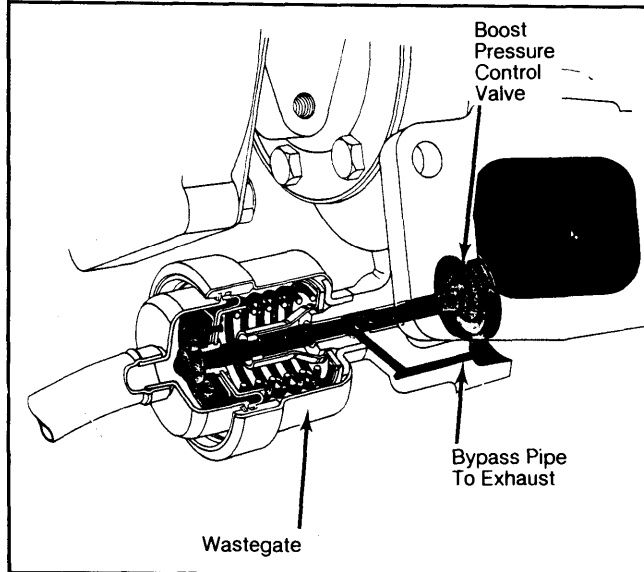

Should boost pressure control valve (wastegate) fail, a pressure switch installed in the intake manifold closes an electrical circuit, energizing a switch-over valve. This valve closes the pressure line to the intake manifold and simultaneously opens the aneroid compensator to atmosphere. This reduces the fuel quantity being injected.

The pressure switch only functions when intake manifold boost pressure reaches 16 psi (1.125 kg/cm²). When pressure drops below this figure, the pressure switch opens the electric circuit and venting of the pressure line is stopped.

LUBRICATION

Oil is supplied to the turbocharger for lubrication and cooling from the rear cover of the oil filter. The oil return line runs from the turbocharger back to the upper oil pan housing. Oil spray nozzles for cooling the pistons are connected internally to the engine lubrication system's main oil gallery. See Fig. 1.

TESTING

1) To check turbocharger boost pressure, connect pressure gauge (617 589 02 21 00) to intake manifold after removing plug.

2) Using a dynamometer, drive vehicle in driving range "S" at full load and 4000 RPM. Boost pressure should be 10.1-11.6 psi (.71-.82 kg/cm²).

3) If boost pressure is too low, check air filter and air intake shroud duct for obstructions. Check turbocharger for leaks between manifold and turbine

housing, compressor housing discharge and intake manifold, and between intake or exhaust manifold and cylinder head.

4) Check pressure line between intake manifold and aneroid compensator and overload switch-over valve. To check valve, turn ignition switch to position "2". Disconnect plug on valve and check for battery voltage at Black/Red wire.

5) If not present, check fuse number 4 or wiring. Check for ground condition of Brown/Black wire. There should be no ground connection below boost pressure of 16 psi (1.13 kg/cm²). If ground exists, check pressure switch in intake manifold or its wiring.

6) Other possible causes of low boost pressure would be a defective wastegate, requiring turbocharger replacement, or problems with the fuel injection pump, requiring removal, testing, and repair.

7) If boost pressure control valve (wastegate) does not open, causing boost pressure at full load operation to exceed 16 psi (1.13 kg/cm²), check hose between compressor housing and wastegate. If hose is leaking or is kinked, replace the hose. If not, replace turbocharger.

NOTE: When dynamometer test is complete, road test vehicle with tester inside the vehicle. Drive vehicle in driving range "L" or "S" at 4000 RPM. Fully depress accelerator pedal and hold engine speed at 4000 RPM with brakes (short test duration only). Boost pressure should be 10.1-11.6 psi (.71-.82 kg/cm²). If not, repeat steps 3) through 6).

REMOVAL & INSTALLATION

TURBOCHARGER ASSEMBLY

Removal

1) Remove air filter and disconnect electrical cable from coolant temperature switch.

2) Loosen hose clamp at air intake duct. Remove vacuum line, crankcase breather pipe, air filter housing and air intake duct. Disconnect engine oil supply line to turbocharger. Remove air filter mounting bracket and disconnect exhaust flange.

3) Disconnect and remove exhaust bracket on automatic transmission. Press exhaust pipe to the rear. Remove mounting bracket for intermediate flange and 4 mounting nuts on the turbocharger.

4) Lift off turbocharger and remove intermediate flange and disconnect oil return pipe at turbocharger.

Installation

1) Install all parts in reverse order of removal. Before mounting the turbocharger, install intermediate flange and oil return pipe. Install flange gasket between turbocharger and exhaust manifold with reinforcing bead towards the exhaust manifold.

2) Use only heatproof nuts and bolts when installing turbocharger. Fill center turbocharger housing with approximately ¼ pint of engine oil through the engine oil supply bore, before operating turbocharger. Be sure "O" rings are mounted correctly when installing air intake duct.