

DATSUN/NISSAN — MAXIMA

DESCRIPTION

The diesel injection system includes a fuel injection pump, fuel filter, fuel lines, injector nozzles and glow plug system. The glow plug system consists of a glow plug control unit (behind left kick panel), 2 glow plug relays and a current flow resistor (on right shock tower) and a water temperature sensor.

OPERATION

FUEL INJECTION PUMP

The injection pump is driven by a belt at the front of the engine. It draws fuel from the tank, pressurizes it, and injects a specific quantity to each cylinder at the proper time. Excess fuel is returned to the tank through another line. In the event of pump failure, the assembly must be replaced as a complete unit. A fuel cut solenoid is used to stop fuel flow when the ignition is turned off.

INJECTION NOZZLES

The injection nozzles spray fuel into a pre-chamber as each compression stroke occurs. Each nozzle has a fuel supply and return line. Nozzles can be disassembled, cleaned and adjusted to correct defective spray patterns. Shims are used to correct nozzle opening pressures, and are available in 14 sizes from .0197 to .0394" (.5-1.0 mm) in increments of .0016" (.04 mm). Changing one size nozzle shim will change injection pressure by 68 psi (4.8 kg/cm²).

Fig. 1: Exploded View of Fuel Injection Nozzle

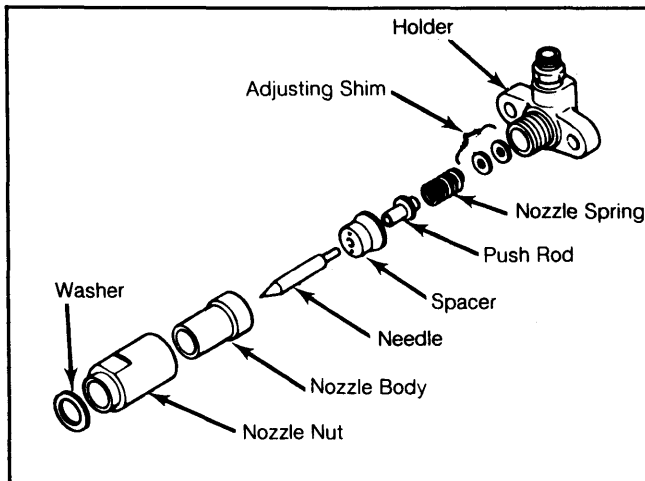

FUEL FILTER

The fuel filter is a sealed cartridge type located on the right side wheel well, just behind the battery. The cartridge should be replaced every 30,000 miles. Water should be drained from the filter housing and the fuel system should be bled whenever the cartridge is replaced.

GLOW PLUGS

The glow plug system used a glow plug control unit, 2 relays and a current flow resistor to control glow plug current. The glow plugs enable the engine to start

easily in cold weather and run smoothly during warm-up. Current is applied to the glow plugs for a specific time which is determined by engine coolant temperature. When the ignition is turned on, a dash mounted glow plug warning light operates for up to 8 seconds. At the same time, the glow plugs themselves will operate for 5 to 30 seconds as an aid to engine warm-up.

TROUBLE SHOOTING

NO FUEL AT NOZZLES

Inspect fuel lines. Drain water and replace filter. Bleed fuel system.

ROUGH IDLE

Adjust idle speed. Check for fuel or air leaks. Check valve clearance and injection pump timing. Check injection nozzles and injection pump drive belt. Adjust or replace as needed.

LACK OF POWER

Check and adjust high idle speed screw. Check fuel filter and lines for leaks or clogs. Check throttle valve for proper operation. Bleed fuel system and drain water. Check engine compression. Check and adjust injection nozzles and valve clearances.

EXCESSIVE SMOKE

Check sticky throttle valve. Check clogged injection nozzles, air and fuel filters. Condition of injection pump drive belt. Check injection pump timing.

NOTE: If the problem remains after the recommended checks, replace injection pump.

EXCESSIVE FUEL CONSUMPTION

Fuel leakage. Check idle and high idle speed adjustments. Adjust injection timing. Check injection nozzle operation.

ENGINE WILL NOT STOP

Check fuel cut solenoid valve. Check for stuck accelerator linkage.

ENGINE NOISE WHEN WARM

Check idle speed and valve clearance. Check other engine rotating assemblies (water pump, alternator, etc.).

TESTING

INJECTION NOZZLES

Opening Pressure

1) Blow out any dirt around injection nozzles, then remove fuel lines, nozzles and nozzle washers. Mark nozzles for correct installation.

2) Install nozzle on pressure tester. Bleed air out, then pump at a rate of 1 stroke per second. Note pressure when nozzle opens.

3) If pressure is not within a range of 1780-1920 psi (125-135 kg/cm²), disassemble and clean nozzle.

1982 Diesel Fuel Injection

DATSUN/NISSAN — MAXIMA (Cont.)

Change shims as necessary to obtain proper opening pressure.

4) Test nozzle again to ensure opening pressure is correct, then check nozzle spray pattern.

Spray Pattern

To test pattern, pump tester handle one time per second. Observe pattern. If not correct, clean or replace nozzle.

Fig. 2: Injection Nozzle Spray Patterns

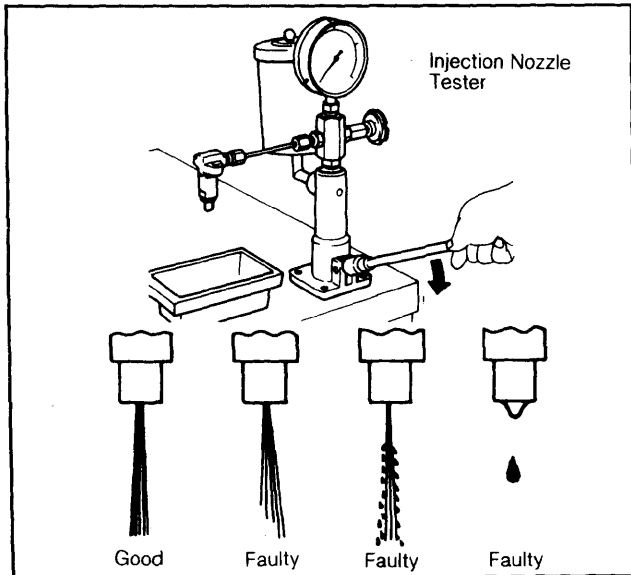

Nozzle Cleaning

1) Disassemble injection assembly. Thoroughly clean all parts in clean solvent. If nozzle needle is damaged or fused, seized or discolored, replace entire nozzle assembly. Check all other parts for excessive wear or damage. Replace as needed.

2) Clean nozzle assembly with a wooden stick and soft brass brush (Datsun/Nissan Nozzle Cleaning Kit IV11289004). Be sure to remove all deposits from adjusting shims, spring, push rod, spacer, nozzle body, needle and seat, and injection hole.

3) Pull needle about halfway out of body and release. Needle should slide smoothly back into place. Repeat this procedure several times, rotating needle slightly each time. If needle does not slide smoothly, replace nozzle body and needle.

GLOW PLUG SYSTEM

Indicator Lamp

1) Indicator lamp should light when coolant temperature is below 122°F (50°C). If not, check bulb. Replace as needed.

2) If bulb is okay, check for battery voltage at terminal 9 of glow plug control unit. If voltage is not present, repair wiring. If present, replace control unit.

System Check

1) If engine will not start or is difficult to start, there may be a problem with the glow plug system. Check that the starter, battery, fuel supply and related systems are operating properly.

2) The glow/filter warning light should come on when key is in "ON" position. If not, check for burned out

Fig. 3: Glow Plug System Wiring Diagram

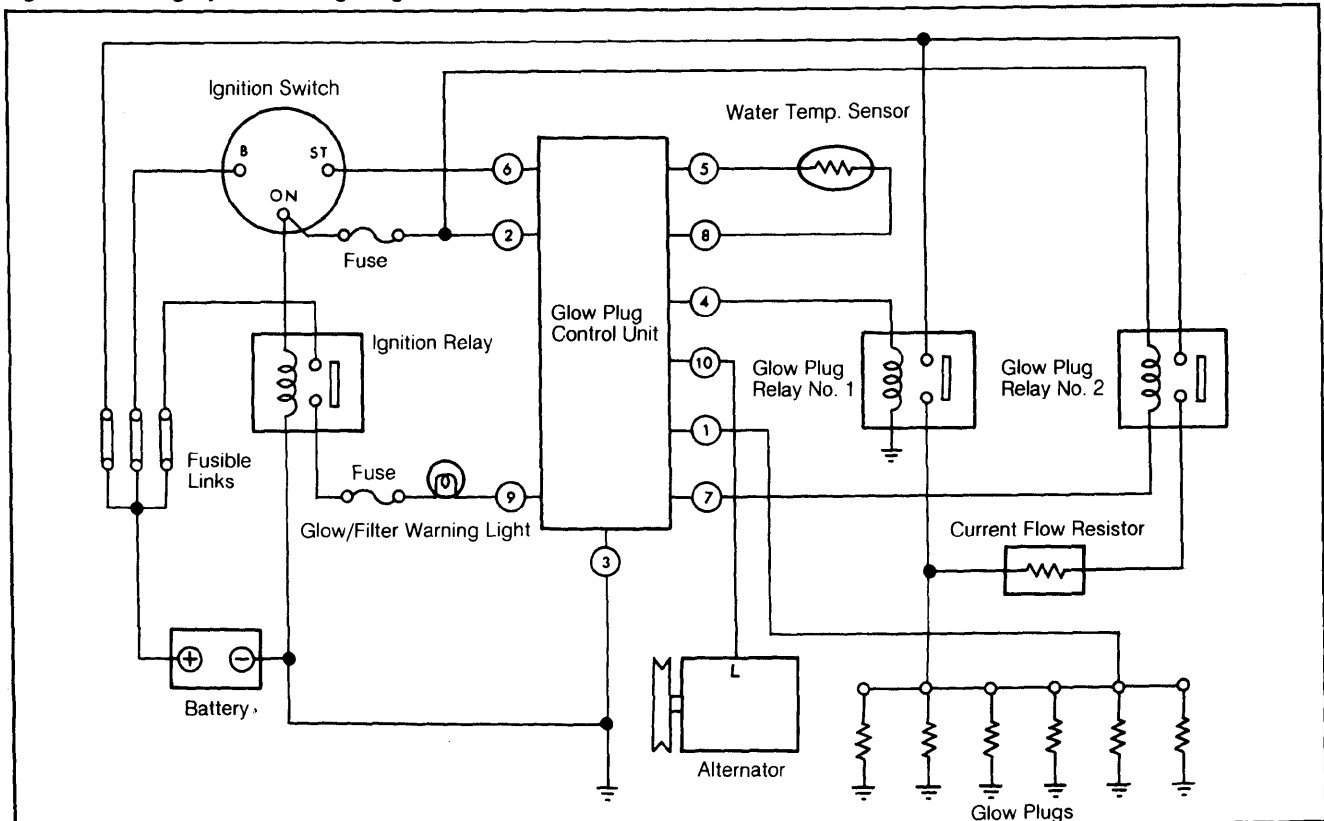

DATSUN/NISSAN — MAXIMA (Cont.)

bulb and replace if needed. If bulb is good, check coolant temperature.

3) Temperature is over 122°F (50°C), re-check starting systems. If below 122°F (50°C) check water temperature sensor and replace if faulty. If sensor is okay, replace glow plug control unit.

Fig. 4: Location of Water Temperature Sensor

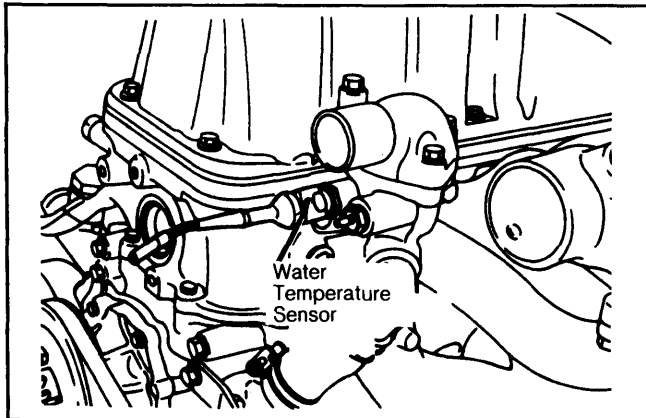
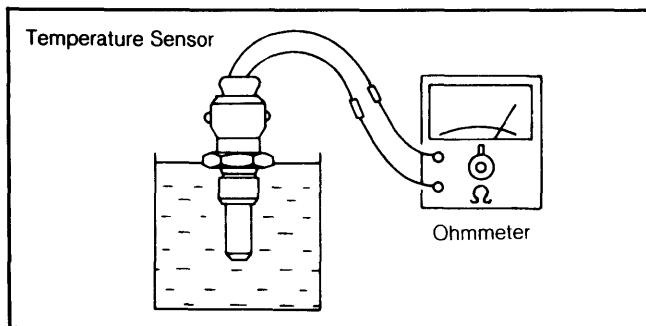

Fig. 5: Checking Temperature Sensor Resistance



TEMPERATURE SENSOR RESISTANCE SPECIFICATIONS

Temperature °F (°C)	Resistance Ohms
50 (10)	32,500-41,500
68 (20)	22,500-27,500
122 (50)	740-940
176 (80)	290-360

4) If glow/filter warning light does come on, see if charge warning light comes on also. If not, check "L" terminal connection on alternator check wiring harness. If charge warning light comes on, check voltage at glow plug terminal within 10 seconds of turning key to "ON" position.

5) If voltage is absent, check for shorts or breaks in wiring harness. Repair as needed. If harness is good, replace glow plug control unit. If voltage is present, measure at terminal after 60 seconds.

6) If voltage is present at terminal, check glow plug relay No. 1. Replace if needed. If relay is good, check glow plug relay No. 2. Replace if needed. If relay No. 2 is good, replace glow plug control unit. See Fig. 6.

7) If no voltage is present at terminal after 60 seconds, check glow plug relay No. 1 for activation. It should activate immediately when key is turned "ON". If not, check as in Fig. 6. Replace if faulty. Replace glow plug control unit if relay is good.

Fig. 6: Glow Plug Relay Test Points

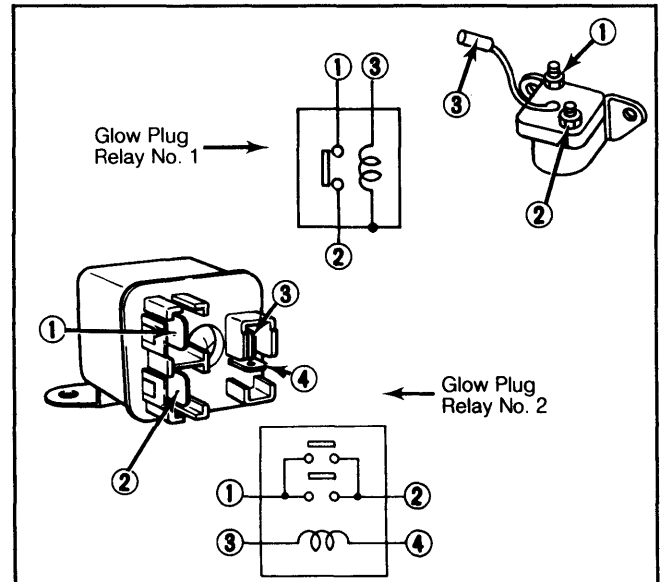

8) If relay No. 1 activates in step 7), check to see if relay No. 2 activates as well. If not, check as in Fig. 6 and replace if faulty. If good, replace glow plug control unit.

9) If relay does activate, measure glow plug resistance. If continuity does not exist, replace glow plug. If it does, check wiring and connections at connecting plate. Replace glow plug control unit if connecting plate is good.

FUEL CUT SOLENOID

Solenoid Check

To check the solenoid, repeatedly apply and remove battery voltage directly to the solenoid. If the solenoid is functioning properly, a distinct clicking sound should be heard. If not, the solenoid is bad and should be replaced. See Fig. 7.

Fig. 7: Checking Fuel Cut Solenoid

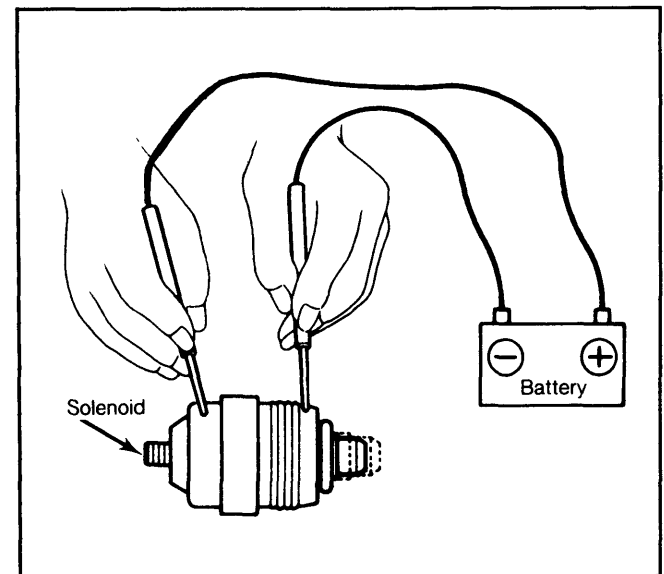

1982 Diesel Fuel Injection

DATSUN/NISSAN — MAXIMA (Cont.)

REMOVAL & INSTALLATION

INJECTION PUMP

Removal

1) Drain coolant and disconnect battery ground cable. Remove radiator, shroud and hoses. Loosen pulley nuts and remove alternator, power steering and air conditioning belts. Remove power steering pump.

NOTE: Do not drain power steering fluid or disconnect hoses from pump during this procedure.

2) Disconnect remaining wires and hoses from pump. Remove dust cover. Loosen spring set pin and set tensioner pulley to "free tension" position. Re-tighten set pin.

3) Remove injection drive belt. Loosen nut and use a gear puller to remove injection pump drive gear.

4) Disconnect injection tubes from injection nozzles. Remove injection pump nuts and bracket bolt. Remove injection pump assembly and injection tubes.

Installation

1) With No. 1 cylinder at TDC on the compression stroke, install injection pump. Install drive gear.

NOTE: There are 2 grooves and 3 belt aligning marks on drive gear. Use groove and belt mark "B" to position the gear.

2) With tensioner pulley in free position, install injection drive belt making sure that the timing marks on the belt are in alignment with the marks on the pump drive pulley and the crank damper.

3) If the marks on the belt are not clear, count the number of belt teeth between the timing marks on the two pulleys. There should be 20 teeth between the two marks.

Fig. 8: Injection Pump Drive Belt Installation

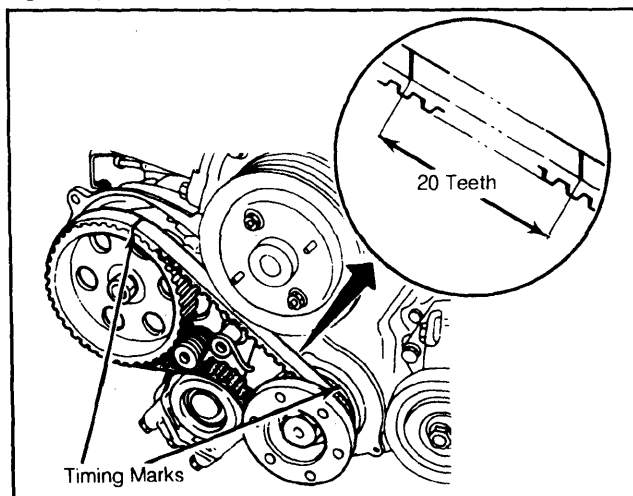

4) Loosen the spring set pin and allow tensioner to return to "tension" position. Adjust injection timing, tighten pump and connect injection tubes.

NOTE: Injection tubes should always be connected in the order: 4, 2, 6, 1, 5, 3 as counted from the front to the rear of the engine.

5) Bleed fuel system. Loosen the priming pump vent screw on the front of the fuel filter housing. Pump the filter priming pump until fuel begins to flow from the vent hole.

6) Tighten vent screw. Disconnect the fuel return hose and attach an overflow hose to the overflow connector. Place a can or other small container under the hose end and pump priming pump until fuel begins to flow from the hose. Replace overflow hose.

FUEL FILTER

Removal & Installation

Remove fuel filter sensor and drain fuel. Remove fuel filter, replace with new filter. Tighten by hand only, do not use a wrench. Before connecting fuel filter sensor, drain water by pumping priming pump until fuel overflows. Install fuel filter sensor, and bleed fuel system.

ADJUSTMENTS

INJECTION PUMP TIMING

1) With No. 1 cylinder at TDC on the compression stroke, remove fuel injection tubes and loosen fork screw on cold start device. Turn fork 90° and set device in the free position. See Fig. 9.

NOTE: Do not remove screw on device wire. If removed, pump assembly will require readjusting.

Fig. 9: Injection Pump Cold Start Device

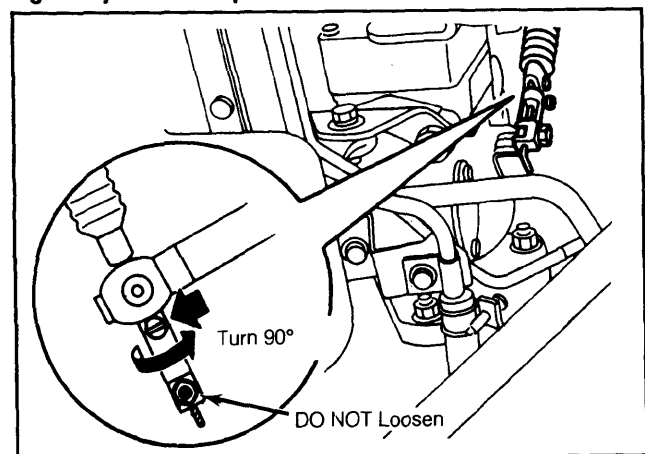

2) Remove plug bolt from rear of injection pump. Install special timing tool with dial indicator (Datsun Part No. KV11229352) in bolt hole.

3) Turn crank to 15-20° BTDC and zero dial indicator. Rotate clockwise 2 complete turns, then loosen and retighten timing belt tensioner.

4) Rotate clockwise to No. 1 cylinder TDC position, compression stroke, and read dial gauge. Gauge should read .0327-.0351" (.83-.89 mm). If reading is out of this range, turn injection pump body until reading is correct.

5) Tighten pump. Remove tool and replace plug bolt using new washer. Reset fork by pulling on cold start device wire. Tighten fork screw. Connect injection tubes.

DATSUN/NISSAN — MAXIMA (Cont.)

Fig. 10: Injection Pump Timing

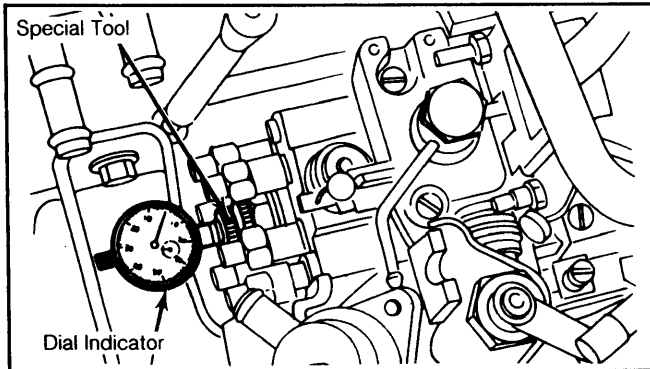

IDLE AND HIGH IDLE SPEED

Adjustment should be made with all electrical accessories off and engine at normal operating temperature.

1) Attach tachometer. With transmission in neutral, run engine at 2000 RPM for 2 minutes.

Fig. 11: Location of Idle Adjusting Screw

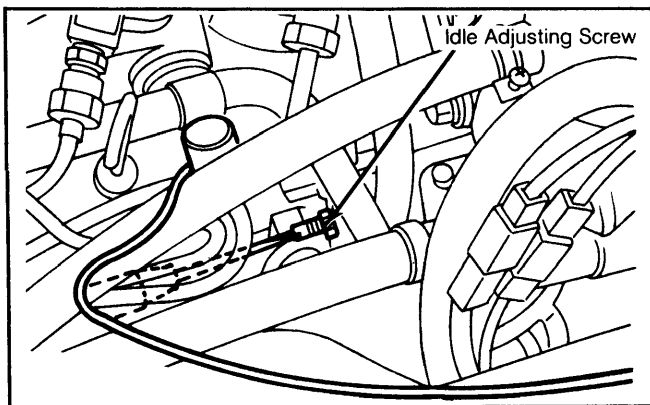

2) Let engine idle for 1 minute. Check idle speed (Auto. Trans. in "D"). Idle should be between 600 and 750 RPM.

3) If adjustment is required, loosen the idle adjusting screw lock nut on idle adjusting screw. Turn

Fig. 12: Fast Idle Adjustment

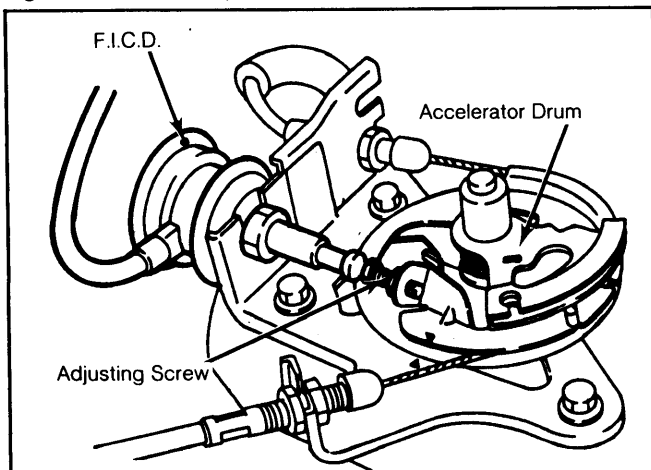

screw until proper idle RPM is obtained. Tighten lock nut. See Fig. 11.

4) With engine idling and air conditioning turned on, set high idle speed. Locate Fast Idle Control Device (F.I.C.D.) diaphragm and turn adjusting screw on accelerator drum to obtain fast idle speed of 800 RPM. See Fig. 12.

TIGHTENING SPECIFICATIONS

Application	Ft. Lbs. (N.m)
Injection Nozzle-to-Cylinder Head	12-15 (16-20)
Injection Nozzle-to-Tube	16-18 (22-25)
Injection Pump Plug Bolt	10-14 (14-19)
Injection Pump Drive Gear	43-51 (60-70)
Injection Pump Bracket Bolt	22-26 (31-36)
Injection Pump Mounting Nuts	12-15 (16-20)