

1982 Fuel Injection

LUCAS-BOSCH AFC SYSTEM

Jaguar XJ6

NOTE: The Lucas-Bosch AFC Fuel Injection system is used on all models. Variations may exist with the addition of auxiliary control systems. This article covers the Lucas-Bosch AFC system in general.

DESCRIPTION

The Lucas-Bosch Air Flow Controlled (AFC) fuel injection system is an electronically controlled system operated by incoming air flow. The AFC fuel injection system also contains a feedback system which measures oxygen content of exhaust gases and maintains the air/fuel ratio at about 14.7:1.

The system consists of an electric fuel pump, fuel pressure regulator, fuel injectors, Electronic Control Unit (ECU), air flow meter, air temperature sensor, throttle switch, coolant temperature sensor, oxygen sensor, 3-way catalytic converter and electrical relays. In addition, all models are equipped with a cold start system to aid in cold engine starts. The cold start system consists of an auxiliary air valve, cold start injector and thermo time switch.

Fig. 1: Jaguar AFC Fuel Injection System

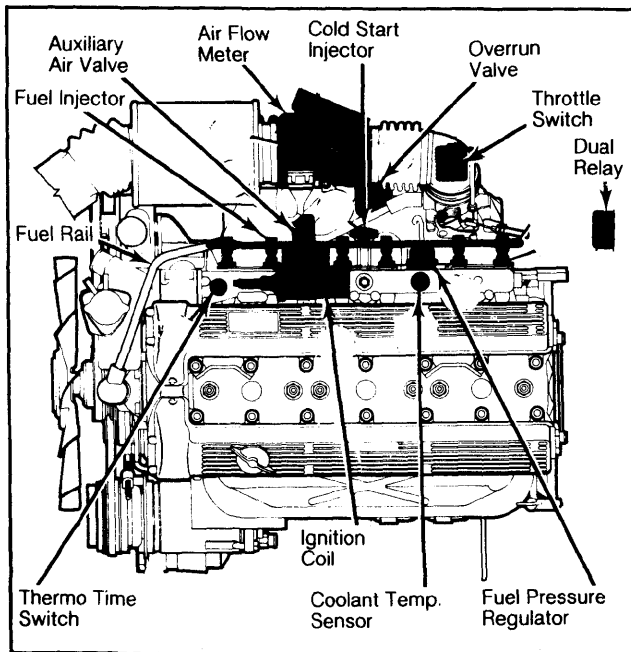

OPERATION

ELECTRIC FUEL PUMP

The electric fuel pump provides fuel under pressure to the fuel pressure regulator. Power for operation during cranking mode is provided from starter relay via the electrical relay. After the engine has started, control of the fuel pump is by a fuel pump circuit in the air flow meter.

The first movement of air flow meter air measuring flap (about 5°) closes the fuel pump contacts

and provides power to fuel pump after engine has started. With engine stopped, no air flow is present, measuring flap closes and fuel pump contacts are opened to cut power to fuel pump. This method of circuitry reduces the risk of fire in a collision. The fuel pump is a sealed unit; no service required.

FUEL PRESSURE REGULATOR

The pressure regulator consists of a sealed, spring loaded diaphragm with a connection for intake manifold vacuum. Fuel is provided to fuel injectors under 36 psi (2.5 kg/cm²) pressure.

A connection for intake manifold vacuum provides a constant pressure differential which ensures that the amount of fuel injected is solely dependent upon injector "open" time. Fuel in excess of fuel pressure or pressure differential is returned to fuel tank. No service of pressure regulator is required.

FUEL INJECTORS

A fuel rail links the fuel pressure regulator with the fuel injectors. Each cylinder is provided with a solenoid-operated injector which sprays fuel toward back of each inlet valve. Each injector is energized through the ignition coil and grounded through the ECU to complete the circuit.

Each injector is linked to a resistor to reduce operating voltage to 3 volts and to protect injectors from power surges. Resistors are located in a single unit mounted on right side of firewall.

The ECU controls the length of time each injector is open. The "open" time of the injector governs the amount of fuel delivered. The injectors deliver 1/2 the amount of fuel required for 1 operating cycle each time they spray (twice per cycle).

ELECTRONIC CONTROL UNIT (ECU)

All components of the control system are electrically connected to the ECU. See Fig. 2. The ECU is a pre-programmed computer which receives and interprets data from various sensors to calculate the amount of fuel required by the engine to maintain efficiency with minimum exhaust emissions.

Fig. 2: Electronic Control Unit (ECU)

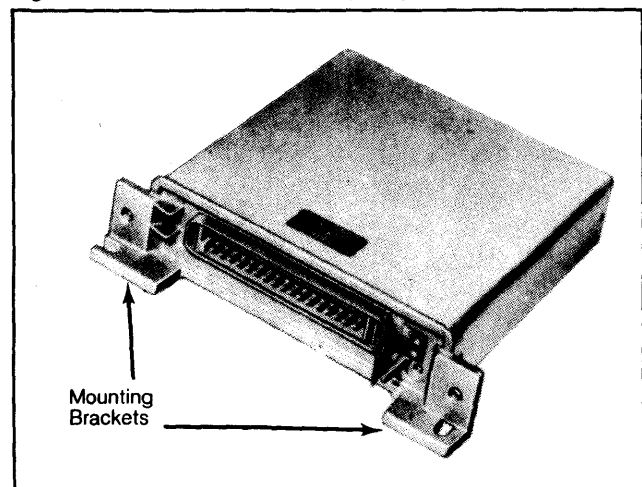

Unit located at front of luggage compartment.

LUCAS-BOSCH AFC SYSTEM (Cont.)

Impulses from the oxygen sensor(s) informs the ECU of oxygen content of exhaust gases and the ECU constantly adjusts the air/fuel ratio by controlling the injector "open" time.

The ECU provides fuel enrichment whenever engine is cranked, regardless of engine temperature. This is activated by a direct electrical connection from the starter circuit to the ECU. The ECU is a sealed unit; no service is required.

AIR FLOW METER

All engine air is drawn through the air flow meter. The meter is basically a tunnel with similarly shaped measuring flap and dampening flap (offset 90° on same casting).

The measuring flap swings on an axis in air stream against reverse pressure of a spiral spring and is connected to a potentiometer. The potentiometer transmits an electrical signal proportionate to the angular displacement of the measuring flap to inform the ECU of engine load. See Fig. 3.

In addition to monitoring air flow, the meter also controls fuel pump operation and idling. At idle, the measuring flap is almost closed due to spiral spring pressure. An idle air by-pass receives air from main air flow through a small hole, the size of which is controlled by the idle mixture screw. This adjustable air by-pass influences CO levels at low engine speeds.

AIR TEMPERATURE SENSOR

The air temperature sensor is an integral component of the air flow meter which converts the temperature of incoming air into electrical signals. These electrical signals are received by the ECU and processed to adjust the amount of fuel injected by the injectors. The air temperature sensor is a non-serviceable device.

Fig. 3: Lucas-Bosch AFC Air Flow Meter

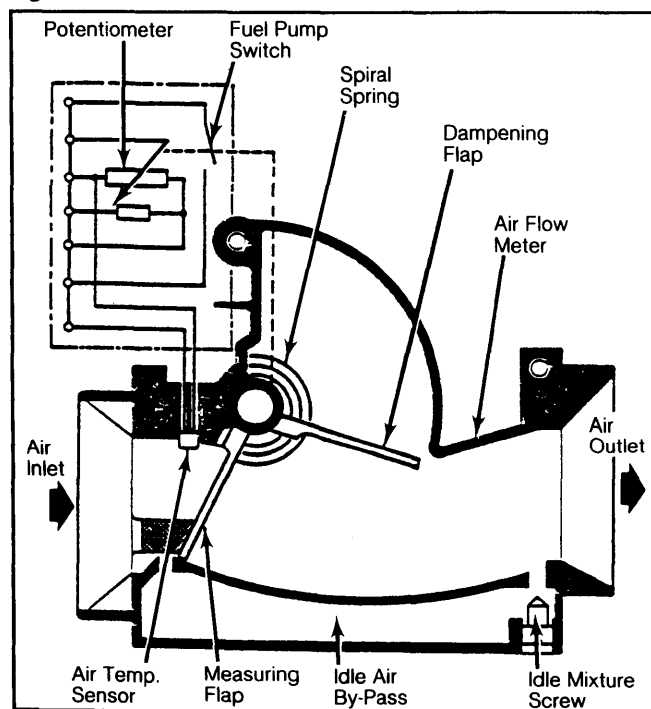

THROTTLE SWITCH

A contact type throttle switch is installed on throttle chamber. The throttle switch sends information on throttle position to ECU. On the contact switch, signals are sent when throttle is at idle or full throttle positions. See Fig. 4.

COOLANT TEMPERATURE SENSOR

This sensor provides ECU with temperature information relating to warm-up enrichment operation. During warm-up period after a cold engine start, additional fuel is required to maintain engine performance. As coolant temperature increases, the ECU decreases fuel enrichment until engine reaches normal operating temperature.

Fig. 4: Contact Type Throttle Switch

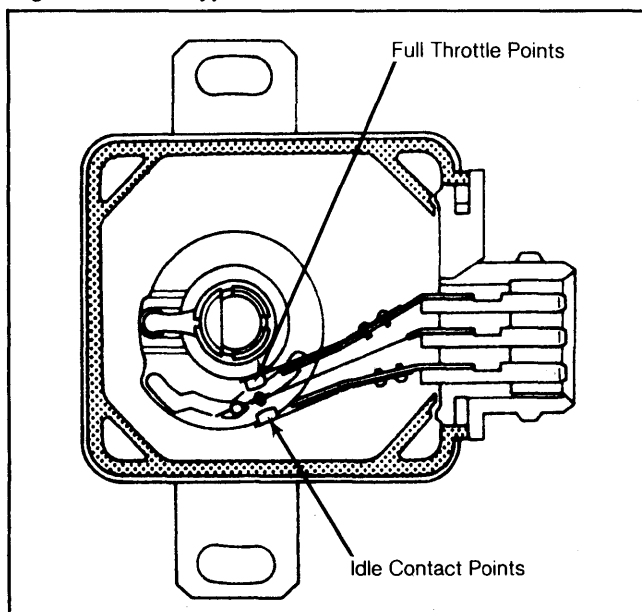

ELECTRICAL RELAYS

The main (double) relay activates the ECU, injector circuit and starting circuit when ignition is switched to start mode. The fuel pump relay activates the fuel pump during start mode. It is then controlled by air flow during operating mode. Relay is located in engine compartment, near battery.

COLD START SYSTEM

The cold start system provides additional air and fuel during cold engine starts. The cold start system consists of an auxiliary air valve which provides additional air, cold start injector which delivers additional fuel and a thermo time switch which controls operation of the cold start system.

The thermo time switch has a bi-metal contact surrounded by a heating coil which is energized during engine cranking. This switch limits cold start system to 5-12 seconds under extreme cold engine starts in relation to engine coolant temperature. When coolant temperature is above 95°F (35°C), bi-metal contact breaks ground circuit of cold start injector and cold start enrichment is bypassed.

1982 Fuel Injection

LUCAS-BOSCH AFC SYSTEM (Cont.)

Fig. 5: Auxiliary Air Valve

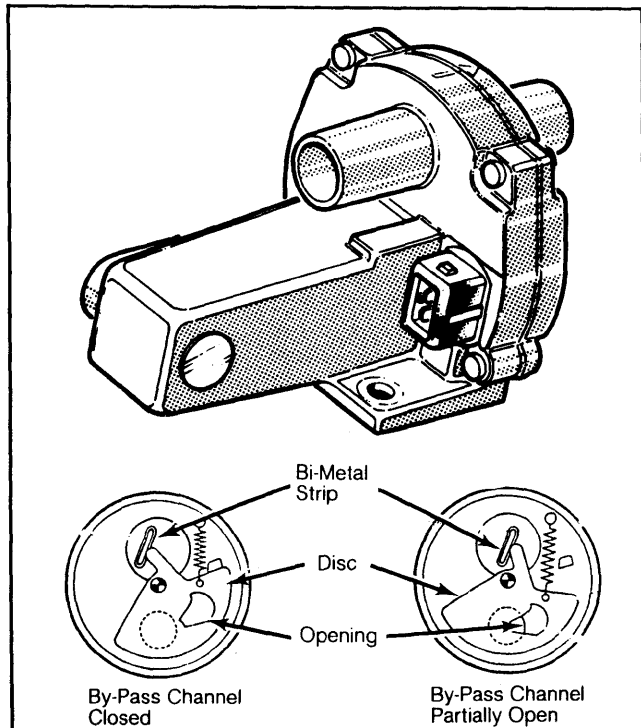

The auxiliary air valve provides additional air during cold engine starts and warm-up period. The valve consists of an electrically heated bi-metal strip, movable disc and air by-pass channel.

The heater coil on the bi-metal strip is energized by the fuel pump relay. Control of the valve is based upon engine temperature; the air by-pass channel is open when engine is cold and gradually closes as temperature rises. At predetermined temperatures, air by-pass channel is blocked and additional air flow stops. See Fig. 5.

TESTING

NOTE: The Lucas-Bosch AFC fuel injection system maintains constant fuel pressure in fuel lines and components at all times. Be sure to relieve pressure before attempting to open system at any point for testing. Do not allow fuel to flow onto engine or electrical parts, or allow an open flame in area while testing fuel system or components.

ELECTRONIC CONTROL UNIT (ECU)

Do not attempt to test ECU, permanent damage could result. It is possible to check plug wires for continuity. The ECU should only be judged faulty after compression is checked, ignition system has been tested and found problem-free, and all other fuel injection components have been thoroughly tested (including wiring).

FUEL PRESSURE

1) Depressurize fuel system by disconnecting fuel pump ground lead and cranking engine for a few

seconds. Turn ignition switch off and reconnect fuel pump ground lead.

2) Disconnect fuel rail at cold start injector and connect fuel pressure gauge. Disconnect negative lead from ignition coil and turn ignition switch on. Pressure reading should be 35.5-37 psi (2.5-2.6 kg/cm²).

3) Slow pressure drop is permissible; sudden pressure drop requires check of entire fuel system for leaks. After testing fuel pressure, depressurize fuel system, remove test equipment and reconnect fuel lines and ignition coil negative lead.

4) Operate fuel change-over switch on dash and recheck reading. Reading from both fuel tanks should agree. On all models, if pressure reading is not to specifications, replace fuel pressure regulator.

AIR TEMPERATURE SENSOR

Disconnect negative battery strap and air flow meter connector. Connect ohmmeter leads to terminals 6 and 27 on potentiometer connector. Readings should be as shown in *Temperature/Resistance Relationship* chart. If not, replace temperature sensor and air flow meter as an assembly.

TEMPERATURE/RESISTANCE RELATIONSHIP

Temperature	Resistance (Ohms)
14°F (-10°C)	9200
32°F (0°C)	5000
68°F (20°C)	2500
104°F (40°C)	1180
140°F (60°C)	600

AUXILIARY AIR VALVE

1) Remove auxiliary air valve connector and connect an ohmmeter to both terminals. Resistance should read approximately 33 ohms. If not, continue testing as follows:

2) Remove auxiliary air valve from inlet manifold and immerse mounting plate in cold water, avoiding contact of terminals and by-pass channel with water.

3) The movable plate should fully expose by-pass channel. Gradually heat water. As temperature increases, channel should become blocked. If valve does not respond as outlined, replace auxiliary air valve.

THERMO TIME SWITCH

1) Using a thermometer, check engine coolant temperature. Compare coolant temperature with value stamped on thermo time switch body. Connect an ohmmeter between terminal "W" on switch and ground.

2) If coolant temperature is higher than switch value, a very high resistance denoting an open circuit should be obtained.

3) If coolant temperature is lower than switch value, a very low resistance denoting a closed circuit should be obtained. If switch does not respond as outlined, replace thermo time switch.

4) If switch passes resistance test, allow coolant temperature to cool below stamped value on switch. With ohmmeter connected, connect battery power via an isolating switch to terminal "G".

5) Using a stop watch, check delay time as ohmmeter changes between high and low resistance.

LUCAS-BOSCH AFC SYSTEM (Cont.)

Delay period should be as shown in Coolant/Delay Time Relationship chart. If not, replace thermo time switch.

COOLANT/DELAY TIME RELATIONSHIP

Temperature (Coolant)	Delay (Seconds)
-4°F (-20°C)	8
32°F (0°C)	4.5
50°F (10°C)	3.5
95°F (35°C)	0

COLD START INJECTOR

1) Remove electrical connector from cold start injector and connect voltmeter across connector terminals. Crank engine with ignition switch. Battery voltage should be present.

2) Release fuel system pressure and remove cold start injector with fuel lines attached. Reconnect electrical connector and place injector in container.

3) As cold engine is cranked with ignition switch, fuel spray should be observed until thermo time switch cuts off relay. When engine is warm, no fuel spray should occur during cranking. If injector does not respond as outlined, replace cold start injector.

COOLANT TEMPERATURE SENSOR

1) Disconnect battery ground cable and electrical connector from sensor. Connect an ohmmeter between sensor terminals. Reading should be as shown in Temperature/Resistance Relationship chart.

2) Disconnect ohmmeter and check resistance between each terminal and sensor body. A very high resistance denoting an open circuit should be obtained. If sensor does not respond as outlined, replace coolant temperature sensor.

TEMPERATURE/RESISTANCE RELATIONSHIP

Temperature (Coolant)	Resistance (Ohms)
14°F (0°C)	9200
32°F (0°C)	5900
68°F (20°C)	2500
104°F (40°C)	1180
140°F (60°C)	600
176°F (80°C)	325

THROTTLE SWITCH

Disconnect battery ground cable and throttle switch electrical connector. Connect a powered test lamp between terminals 3 and 18 of throttle switch. Open throttle; test lamp should glow when throttle nears wide open position. If not, replace throttle switch.

REMOVAL & INSTALLATION

AIR FLOW METER

Removal & Installation

Disconnect battery ground cable. Disconnect rubber hose from both sides of air flow meter. Disconnect air flow meter ground cable and remove bolts securing meter to bracket. Move air flow meter upward, disconnect

electrical connector and remove air flow meter. To install, reverse removal procedure.

ELECTRONIC CONTROL UNIT (ECU)

Removal

Disconnect battery ground cable. ECU is located at forward end of luggage compartment. Remove ECU cover, retaining band and cable clamp clip. Unclip end cover and lift out ECU. Disconnect pin connector and remove ECU.

Installation

To install, reverse removal procedure, making sure pin connector is installed squarely and securely.

COLD START INJECTOR

Removal & Installation

Disconnect battery ground cable and remove electrical connector from injector. Release fuel line pressure. Remove injector retaining screws and remove injector. To install, reverse removal procedure.

AUXILIARY AIR VALVE

CAUTION: Auxiliary air valve removal should be done only when engine is cold. Removal of valve requires having replacement valve ready for immediate installation or draining cooling system below level of valve.

Removal

Disconnect battery ground cable. Disconnect air hoses and electrical connector from auxiliary air valve. Remove coolant system cap. Remove valve retaining bolts and air valve.

Installation

Clean all gasket material from mating surfaces without damaging seating area. To install, coat new gasket with non-hardening sealing compound and reverse removal procedure.

COOLANT TEMPERATURE SENSOR

CAUTION: Coolant temperature sensor removal should be done only when engine is cold. Removal of sensor requires having replacement sensor ready for immediate installation or draining cooling system below level of sensor.

Removal & Installation

Disconnect battery ground cable. Drain coolant and disconnect sensor electrical connector. Loosen and remove sensor. To install, reverse removal procedure using suitable sealing compound on sensor threads. Replace sealing washers, if equipped.

THERMO TIME SWITCH

CAUTION: Thermo time switch removal should be done only when engine is cold. Removal of switch requires having replacement switch ready for immediate installation or draining cooling system below level of switch.

Removal & Installation

Disconnect battery ground cable. Drain coolant and disconnect switch electrical connector. Loosen and remove switch. To install, reverse removal procedure using suitable sealing compound on switch threads.

