

# 1982 Fuel Injection

## BOSCH AFC — EUROPEAN MODELS

BMW 528e, 633CSi, 733i; Fiat Spider 2000 & 2000 Turbo, X1/9; Porsche 928, 944; Renault 18i, Fuego, Fuego Turbo, Volkswagen Vanagon

**NOTE:** The Bosch AFC Fuel Injection system is used on all models. Variations may exist between model applications with the addition of auxiliary control systems. This article covers the Bosch AFC system in general, with manufacturer's differences noted. Federal Vanagon models do not use an oxygen sensor, so disregard oxygen sensor information for these vehicles.

### DESCRIPTION

The Bosch Air Flow Controlled (AFC) fuel injection system is an electronically controlled system operated by incoming air flow. The AFC fuel injection system also contains a feedback system which measures oxygen content of exhaust gases and maintains the air/fuel ratio at about 14.7:1.

The fuel injection system consists of an electric fuel pump, fuel pressure regulator, fuel injectors, Electronic Control Unit (ECU), air flow meter, air temperature sensor, throttle switch, coolant temperature switch (cylinder head temperature switch on Vanagon), oxygen sensor, catalytic converter and electrical relays.

In addition, all models except Porsche 944 are equipped with a cold start system to aid in cold engine starts. The cold start system consists of an auxiliary air valve, cold start injector and thermo time switch. An air conditioning solenoid valve is installed on Renault models equipped with air conditioning to provide additional air when compressor is activated.

Fiat Spider 2000 Turbo models are equipped with a boost enrichment circuit, load enrichment circuit

and an overboost protection circuit which provide necessary information to ECU on turbo operation.

California Vanagon models are equipped with a speed limit switch between throttle switch and ECU which deactivates the oxygen sensor at engine speeds in excess of 3000 RPM. BMW, Porsche 944 and Renault Fuego Turbo models are equipped with electronic engine control. On these vehicles the ECU controls ignition timing in addition to fuel injection.

**Fig. 2: BMW AFC Fuel Injection System**

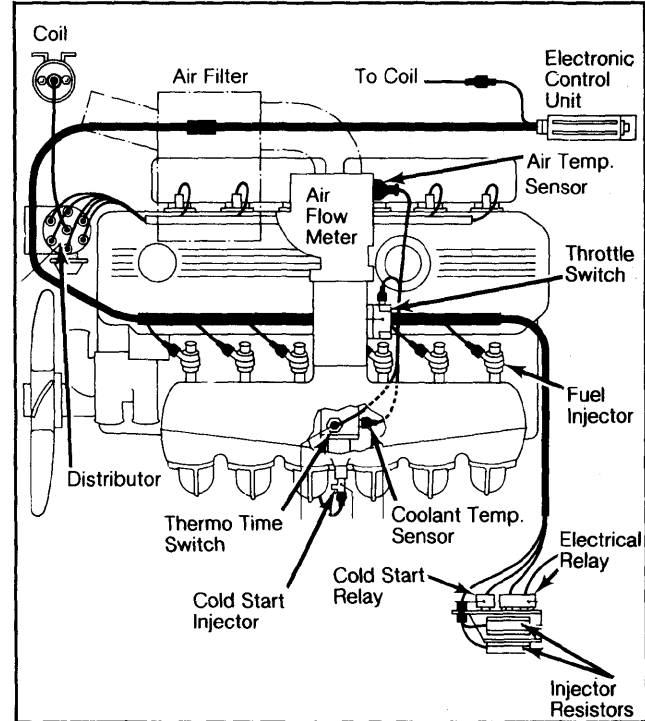

**Fig. 1: Fiat AFC Fuel Injection System**

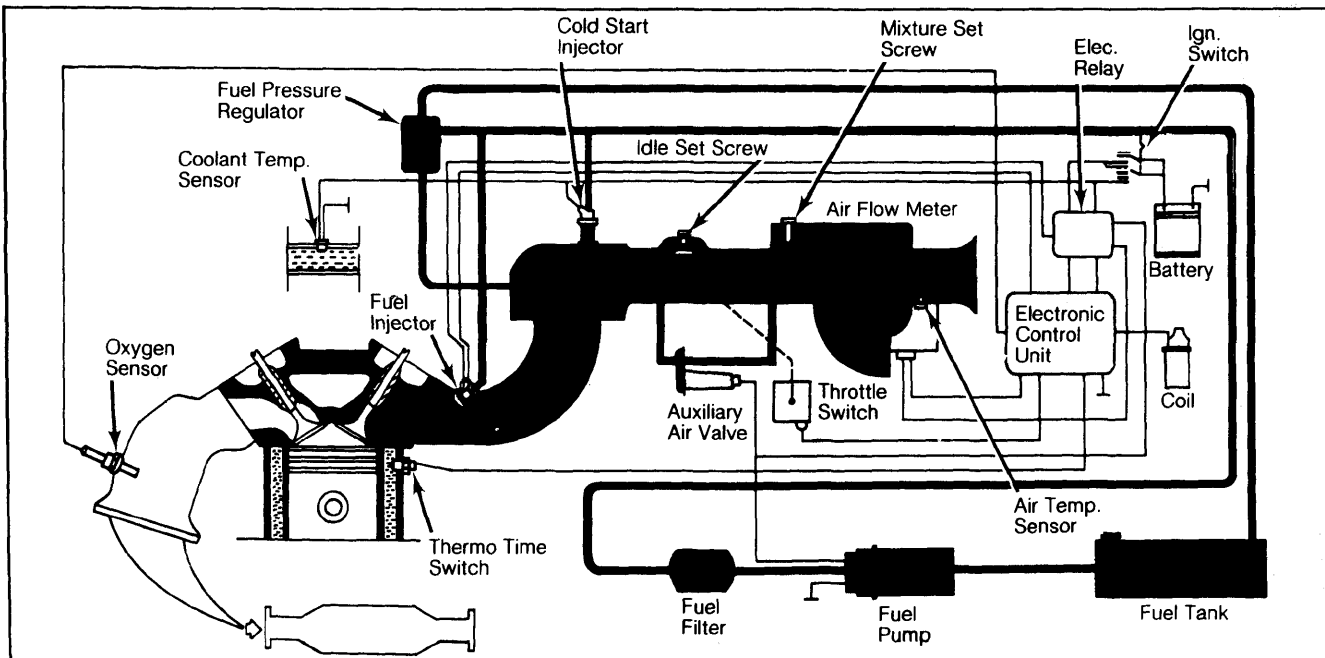

## BOSCH AFC — EUROPEAN MODELS (Cont.)

### ELECTRIC FUEL PUMP

The fuel pump provides fuel under pressure to the fuel pressure regulator. Power for operation during cranking mode is provided from starter relay via the fuel pump relay. After the engine has started, control of the fuel pump is by a fuel pump circuit in the air flow meter.

The first movement of the air flow meter air measuring flap (about 5°) closes the fuel pump contacts and provides power to fuel pump after engine has started. With engine stopped, no air flow is present, measuring flap closes and fuel pump contacts are opened to cut power to fuel pump. This circuit reduces the risk of fire in a collision. The fuel pump is a sealed unit. No service is required.

### FUEL PRESSURE REGULATOR

The pressure regulator (2 regulators on Porsche 928) consists of a sealed, spring loaded diaphragm with a connection for intake manifold vacuum. Fuel is provided to fuel injectors under approximately 36 psi (2.5 kg/cm<sup>2</sup>) pressure.

A connection for intake manifold vacuum provides a constant pressure differential which ensures that the amount of fuel injected is solely dependent upon injector "open" time. Excess fuel is returned to fuel tank. No service of pressure regulator is required.

**Fig. 3: Porsche 928 AFC Fuel Injection System**

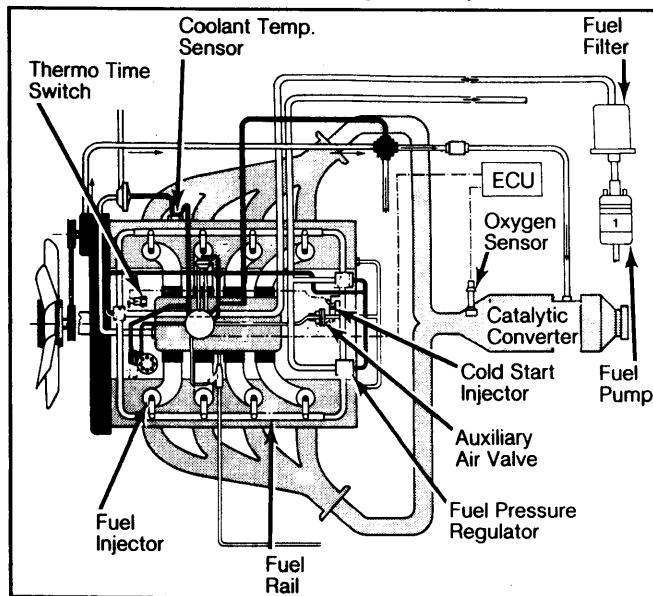

### FUEL INJECTORS

A fuel rail links the fuel pressure regulator with the fuel injectors. Each cylinder is provided with a solenoid-operated injector which sprays fuel towards back of each inlet valve. Each injector is energized through the ignition coil and grounded through the ECU to complete the circuit.

Each injector is linked to a resistor (resistor may be external or integral with injector or ECU) to reduce operating voltage to 3 volts and to protect injectors from power surges. The ECU controls the length of time each injector is open.

The "open" time of the injector governs the amount of fuel delivered. The injectors deliver 1/2 the

amount of fuel required for an operating cycle each time they open (twice per cycle).

**Fig. 4: Renault 18i AFC Fuel Injection System**

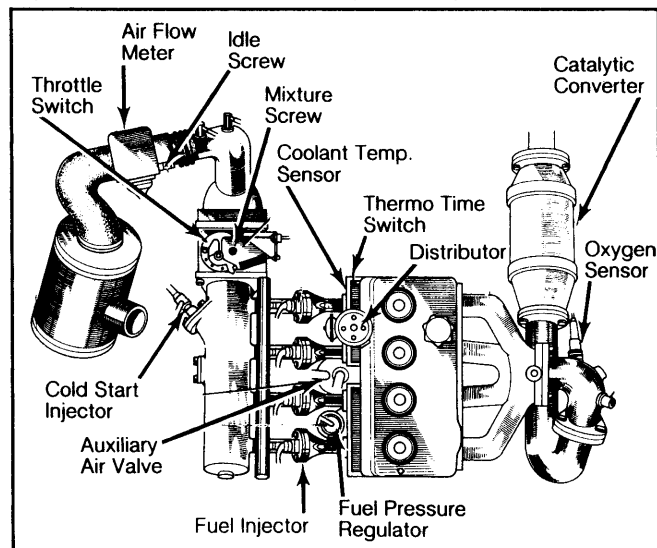

### ELECTRONIC CONTROL UNIT (ECU)

All components of the control system are electrically connected to the ECU. See Fig. 5. The ECU is a preprogrammed computer which receives and interprets data from various sensors. It calculates the amount of fuel required by the engine to maintain efficiency with minimum exhaust emissions.

Impulses from the oxygen sensor inform the ECU of oxygen content of exhaust gases and the ECU constantly adjusts the air/fuel ratio by controlling the injector "open" time.

The ECU provides fuel enrichment whenever engine is cranked, regardless of engine temperature. This is activated by a direct electrical connection from the starter circuit to the ECU. On BMW, Porsche 944 and Renault Fuego Turbo models, the ECU also controls ignition timing. The ECU is a sealed unit. No service is required.

**Fig. 5: Electronic Control Unit (ECU)**

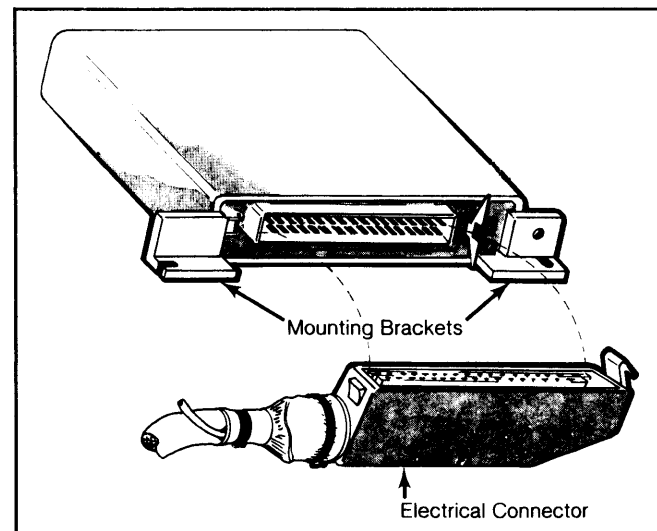

# 1982 Fuel Injection

## BOSCH AFC — EUROPEAN MODELS (Cont.)

### AIR FLOW METER

All engine air is drawn through the air flow meter. The meter contains a tunnel with measuring flap and dampening flap (offset 90° on same casting). The measuring flap swings in air stream against pressure of a spiral spring and is connected to a potentiometer.

The potentiometer transmits an electrical signal determined by the measuring flap position to inform the ECU of engine load. See Fig. 6. In addition to monitoring the air flow, the meter also controls fuel pump operation and idling. At idle, the measuring flap is almost closed due to spiral spring pressure.

An idle air by-pass receives air from main air flow through a small hole, the size of which is controlled by the idle mixture screw. This adjustable air by-pass influences CO levels at low engine speeds.

Fig. 6: Bosch AFC Air Flow Meter

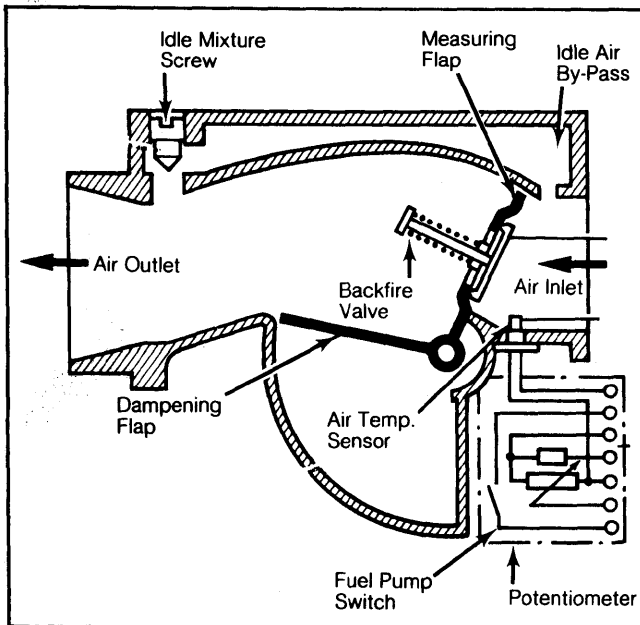
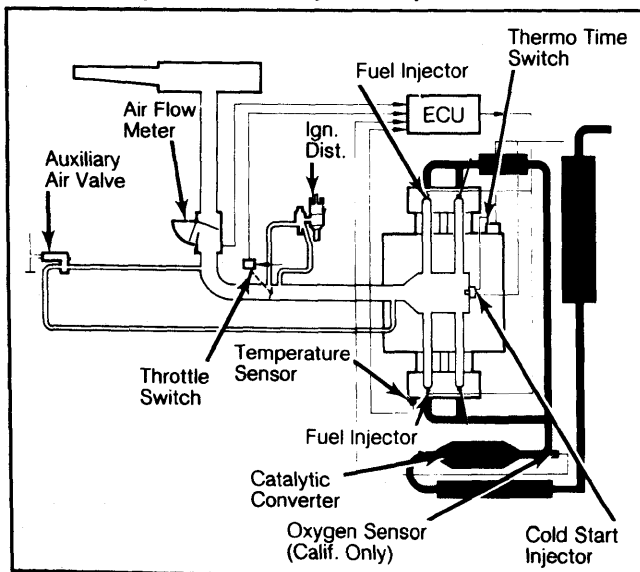

Fig. 7: Vanagon AFC Fuel Injection System



### AIR TEMPERATURE SENSOR

The air temperature sensor is part of air flow meter. It converts the temperature of incoming air into electrical signals. These signals are received by the ECU and used to adjust the amount of fuel injected. The air temperature sensor is a non-serviceable device.

### THROTTLE SWITCH

A contact-type throttle switch is installed on the throttle chamber of all models. It converts throttle position into electrical signals to inform ECU of throttle position. See Fig. 8.

The potentiometer within the air flow meter prevents loss of engine power during sudden acceleration/deceleration by signaling the ECU of necessary fuel enrichment requirements.

Fig. 8: Contact Type Throttle Switch

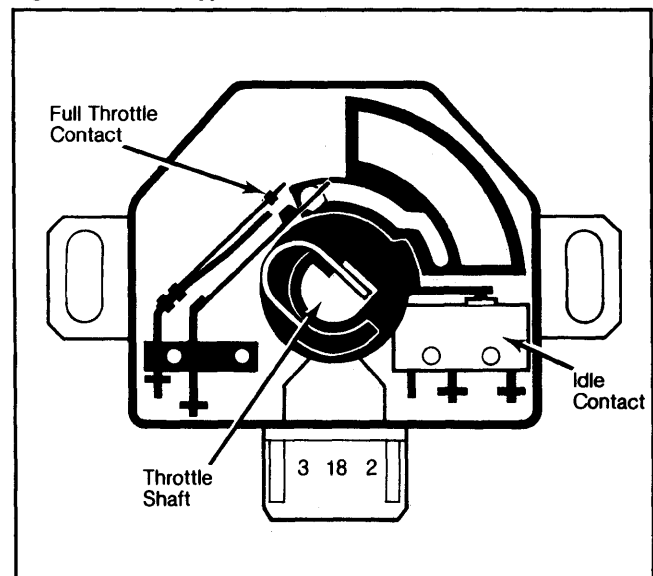

All models except Vanagon.

### COOLANT TEMPERATURE SENSOR

**NOTE:** Vanagon models use a temperature sensor located in cylinder head. Any reference made to coolant temperature sensor within this article also applies to the Vanagon temperature sensor.

This sensor provides ECU with engine temperature information relating to warm-up enrichment operation. During warm-up period after a cold engine start, additional fuel is required to maintain engine performance. As engine temperature increases, the ECU decreases fuel enrichment until engine reaches normal operating temperature.

### ELECTRICAL RELAYS

The main relay activates the ECU, injector circuit and starting circuit when ignition is switched to start mode. The fuel pump relay activates the fuel pump during the start mode and is then controlled by air flow during operating mode. Some models incorporate all relays within a single relay set or dual relay. The cold start system is also activated through the relay set.

## BOSCH AFC — EUROPEAN MODELS (Cont.)

**NOTE:** Relay set is located in following positions: **BMW models** — 528e, bracket above power brake cylinder; 633CSi, behind coolant reservoir; 733i, right side of firewall. **Renault models** — under passenger seat. **Vanagon models** — left side of firewall.

### COLD START SYSTEM

**NOTE:** Porsche 944 does not use cold start system. Instead, additional fuel for cold starts is supplied through injectors.

The cold start system provides additional air and fuel during cold engine starts. It consists of an auxiliary air valve which provides additional air, cold start injector which delivers additional fuel and a thermo time switch which controls operation. The thermo time switch has a bi-metal contact surrounded by a heating coil which is energized during engine cranking.

This switch limits cold start system operation to 5-12 seconds during extremely cold engine starts. When engine temperature is above 95°F (35°C), bi-metal contact breaks ground circuit of cold start injector and cold start enrichment is by-passed.

### AUXILIARY AIR VALVE

The auxiliary air valve provides additional air during cold engine starts and warm-up. The valve consists of an electrically heated bi-metal strip, movable disc and air by-pass channel. The heater coil on the bi-metal strip is energized by the fuel pump relay.

**Fig. 9: Auxiliary Air Valve**

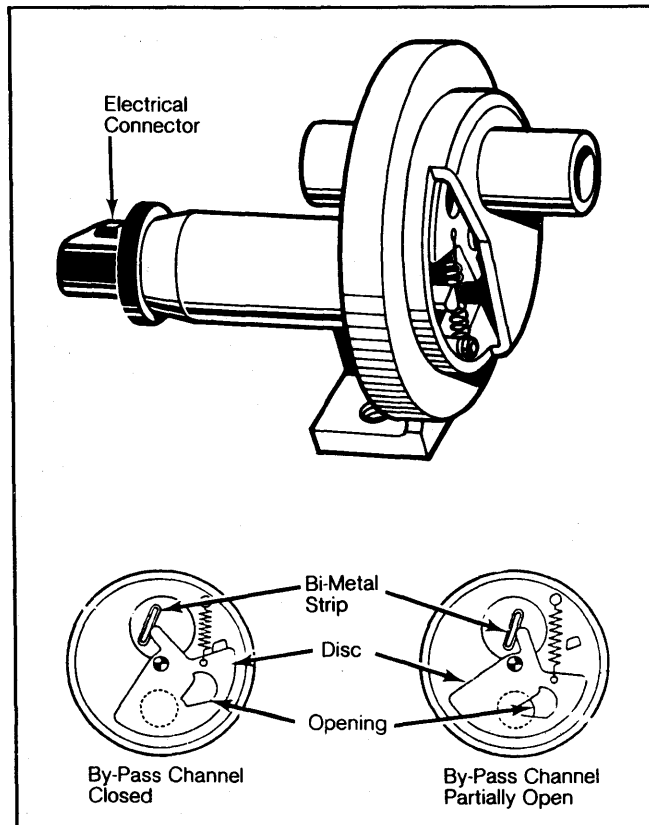

By-pass channel closes as engine temperature rises.

Control of the valve is based upon engine temperature. The air by-pass channel is open when engine is cold and gradually closes as temperature rises. At predetermined temperatures, air by-pass channel is blocked and additional air flow stops. See Fig. 9.

### AIR CONDITIONING SOLENOID VALVE RENAULT ONLY

On vehicles equipped with air conditioning, a solenoid valve delivers additional air to compensate for drop in idle speed when air conditioner is activated.

The solenoid is electrically actuated through the compressor clutch circuit to open a circuit behind throttle plate. The diameter of the air circuit on manual transmission models is 0.12" (3.0 mm) and 0.14" (3.5 mm) on automatic transmission models. See Fig. 10.

**Fig. 10: Renault Air Conditioning Solenoid Valve**

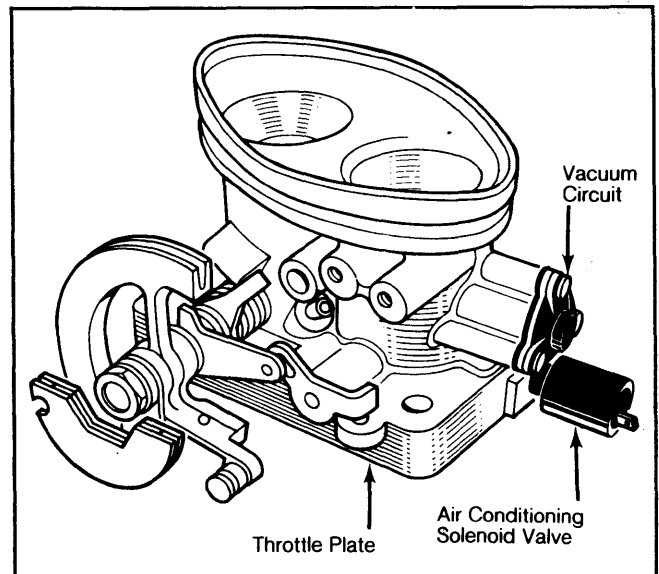

### FIAT TURBO ACCESSORIES FIAT SPIDER 2000 TURBO ONLY

The addition of a turbocharger to the Fiat Spider 2000 requires additional devices. These devices and their operation is as follows:

#### Boost Enrichment Circuit

This circuit consists of 2 boost pressure switches wired into the fuel injection electrical system. These switches provide an electrical signal to the ECU to provide additional fuel while engine is operating with boost from the turbocharger. See Fig. 11.

#### Load Enrichment Circuit

This circuit consists of 1 boost pressure switch wired into the throttle switch of the fuel injection electrical system. This switch provides a wide open throttle signal to the ECU whenever boost pressure is present, which in turn signals the ECU to provide power enrichment. See Fig. 11.

#### Overboost Protection Circuit

This circuit consists of 1 boost pressure switch wired into the fuel injection electrical system. If boost pressure exceeds 9 psi (.66 kg/cm<sup>2</sup>), the overboost switch opens, signaling the ECU that boost pressure is excessive.

# 1982 Fuel Injection

## BOSCH AFC — EUROPEAN MODELS (Cont.)

The ECU then cuts electrical signal to the fuel injectors. When boost pressure drops within safe limits, the overboost switch closes and ECU provides power to fuel injectors. See Fig. 11.

Fig. 11: Fiat Spider 2000 Turbo Accessories

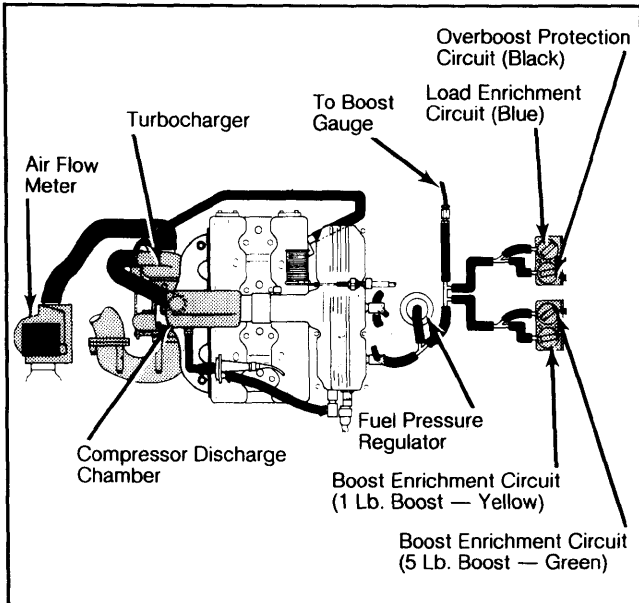

### PORSCHE 944 ACCESSORIES

Electronic engine control (control of both fuel injection and ignition timing) on these vehicles requires additional devices. These devices include speed sensor and reference sensors on flywheel, a pressure damper located at inlet of injector collector tube, and a high altitude switch.

### RENAULT TURBO ACCESSORIES FUEGO TURBO ONLY

Electronic engine control (control of both fuel injection and ignition timing) on turbo models requires additional devices. These devices include magnetic position sensor on clutch housing, vacuum sensor on electronic control unit, and spark knock detector on cylinder head.

## TESTING

**NOTE:** The Bosch AFC fuel injection system maintains constant fuel pressure in fuel lines and component parts at all times. Be sure to relieve pressure before attempting to open system at any point for testing. For further testing of related components on BMW vehicles, see BMW MOTRONIC EMISSION CONTROL SYSTEM in EXHAUST EMISSION SYSTEMS Section.

### ELECTRONIC CONTROL UNIT

Do not attempt to test ECU, as permanent damage could result. It is possible to check plug wires for continuity. The ECU should only be judged faulty after compression is checked, ignition system has been tested and found free of problems, and all other fuel injection

components have been thoroughly tested (including wiring).

## FUEL PRESSURE

### Fiat

1) Release fuel system pressure. Disconnect vacuum hose from fuel pressure regulator. Remove fuel supply line at cold start injector and connect fuel pressure gauge in line with a "Y" connector.

2) Crank engine and check pressure reading in Fuel Pressure Specifications chart. If pressure is lower or higher than specified, pinch return fuel line. If pressure increases, replace regulator. If pressure remains constant, check fuel pump operation. If no reading is measured, replace fuel pump and repeat test.

### Porsche

1) Remove capped nut from test connection on fuel rail without damaging seal. Connect fuel pressure gauge to test connection. Working inside passenger compartment, fold up passenger foot support (if equipped) and unplug fuel pump relay from central electric board.

2) Fuel pump relay is second box from right side on bottom row on 928, second box from left in row furthest from fuses on 944. Using jumper wire, connect together terminals 30 and 87 for 928, 30 and 87b on 944. Fuel pump should run. Fuel pressure should be as specified in chart. If not, replace fuel pump.

### All Other Models

1) Release fuel system pressure. Remove fuel supply line at cold start injector and connect fuel pressure gauge. Disconnect vacuum hose from pressure regulator and connect hand vacuum pump to regulator. Start engine and check pressure reading in Fuel Pressure Specifications chart.

2) Apply 16 in. Hg to pressure regulator. Reading should drop to approximately 29 psi (2.0 kg/cm<sup>2</sup>). If pressure is too low, check fuel pump delivery rate. If pressure is too high, check fuel return line. If readings are still not as specified, replace regulator.

## FUEL PRESSURE SPECIFICATIONS

Application	Pressure psi (kg/cm <sup>2</sup> )
Fiat	
X1/9 .....	33-39 (2.3-2.7)
Spider & Spider Turbo .....	39-45 (2.7-3.2)
All Others .....	33-39 (2.3-2.7)

## FUEL PUMP CIRCUIT

1) Remove electrical connector from air flow meter. Connect terminals 36 and 39 with jumper wire. Disconnect fuel input line at fuel pressure regulator and place in container. Turn ignition on and push air measuring flap open.

2) Fuel should flow into container. If fuel does not flow but clicking sound is heard, replace fuel pump. Fuel circuit is good. If no clicking sound is heard, replace air flow meter assembly and repeat test.

## AIR TEMPERATURE SENSOR

**NOTE:** Testing procedure not available for Porsche or Renault.

## BOSCH AFC — EUROPEAN MODELS (Cont.)

Turn ignition switch off. Disconnect electrical connector at air flow meter and connect ohmmeter between terminals 6 and 22 on BMW, 6 and 27 on all others. Readings should be as follows. If not, replace temperature sensor and air flow meter as an assembly.

### TEMPERATURE/RESISTANCE RELATIONSHIP

Temperature	Resistance (Ohms)
14°F (-10°C) .....	7,000-12,000
68°F (20°C) .....	2,000-3,000
122°F (50°C) .....	1 760-970

<sup>1</sup> — Fiat 250-400 ohms.

### AIR FLOW METER POTENTIOMETER

**NOTE:** Testing procedures not available for BMW, Porsche or Renault models.

Turn ignition switch off. Disconnect electrical connector from air flow meter and connect ohmmeter between terminals shown in table and note readings. If readings are not to specifications, replace air flow meter.

### AIR FLOW METER RESISTANCE

Terminal No.	Resistance (Ohms)
6 & 7 .....	<sup>1</sup> 40-300
6 & 8 .....	<sup>1</sup> 30-260
6 & 9 .....	<sup>1</sup> 200-400
7 & 8 .....	100-500
8 & 9 .....	70-140

<sup>1</sup> — Vanagon only.

### AUXILIARY AIR VALVE

**NOTE:** Testing procedures not available for Porsche.

#### BMW

1) With engine at normal operating temperature and idle speed set to specifications, turn air conditioner on. Connect ohmmeter to Black wire of valve connector.

2) Voltage should be registered and air should flow through valve. Turn air conditioner off. No voltage or air should flow through valve. If valve does not respond as outlined, replace auxiliary air valve.

#### Fiat

1) With engine warm and at idle speed, pinch off hose between throttle chamber and air valve. Engine speed should drop. If not, proceed to next step.

2) Remove hoses from each end of regulator. Visually check opening in valve. Valve should be open when cold and should close as temperature increases.

3) Check continuity of valve at electrical connector. If continuity does not exist, air valve is defective and should be replaced. Check operation of valve by carefully prying valve open with a flat bladed screwdriver and then closing valve. Replace valve if operation is not smooth.

#### Renault

1) Warm engine to temperature of about 68°F (20°C) and stop engine. Disconnect air hoses and electrical connector from valve. Visually check that

diaphragm is partially open. Connect battery power to valve terminals. After 8 minutes, diaphragm should be completely closed.

2) If not, check internal resistance of valve with an ohmmeter connected to both terminals. Resistance should be 40 ohms on turbocharged models, and 49 ohms on all others. If valve does not respond as outlined, replace auxiliary air valve.

#### Volkswagen

1) Disconnect electrical connector and connect ohmmeter leads to valve terminals. Resistance should measure approximately 30 ohms. Pull off hoses and disconnect ohmmeter. Valve should be open on cold engine and closed on warm engine.

2) Reconnect electrical connector and turn ignition switch "ON". Valve should be completely closed after 5 minutes. If valve does not respond as outlined, replace auxiliary air valve.

### THERMO TIME SWITCH

**NOTE:** Testing procedures not available for Porsche.

#### BMW

1) Disconnect electrical connector at thermo time switch. Connect ohmmeter to terminal "G" and ground. Reading should be 40-70 ohms.

2) Connect ohmmeter between terminal 85 ("W" on switch) and ground. Using a jumper wire, connect terminal 86 with terminal 30 ("G" on switch). For temperatures above 59°F (115°C), zero reading should be obtained for 0-8 seconds.

**NOTE:** Terminal "W" on 528e thermo time switch is connector terminal number 86c.

#### Fiat

1) Disconnect electrical connector from cold start injector. Connect test light between terminals, operate starter and note time test light glows. Light should not glow if coolant temperature is above 95°F (35°C) and should glow for 1-8 seconds at temperatures below 95°F (35°C).

2) If light does not glow as outlined, check relay and wiring. If good, replace thermo time switch.

#### Renault

1) Remove thermo time switch and install plug to prevent loss of coolant. Cool thermo time switch by

**Fig. 12: Testing Renault Thermo Time Switch**

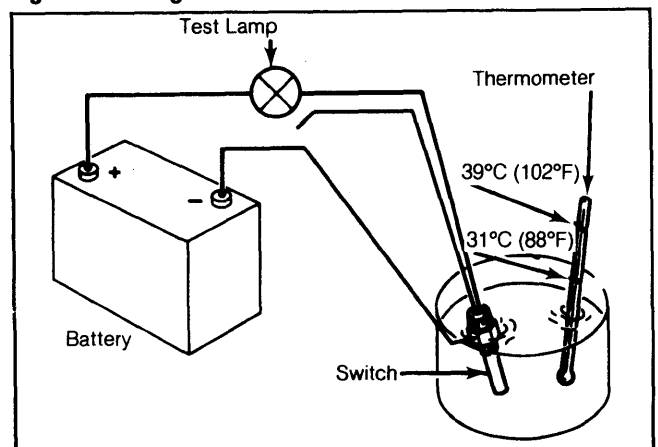

# 1982 Fuel Injection

## BOSCH AFC — EUROPEAN MODELS (Cont.)

immersing in cold water. Connect Black wire to a test lamp and battery positive terminal. Connect battery negative terminal to switch body. Test lamp should glow. See Fig. 12.

2) Insert thermometer in water and gradually heat water. Test lamp should glow until temperature reaches 88-102°F (31-39°C). If switch does not respond as outlined, continue testing as follows:

3) Cool switch to temperature below that stamped on side of switch. Connect ohmmeter between terminal "G" and switch housing (ground). Reading should be 25-40 ohms. Connect ohmmeter between terminal "W" and ground. Reading should be 0 ohms. Connect ohmmeter between both terminals. Reading should be 25-40 ohms.

4) Heat switch to temperature above 104°F (40°C). Connect ohmmeter between terminal "G" and switch housing (ground). Reading should be 50-80 ohms. Connect ohmmeter between terminal "W" and ground.

5) Reading should be 100-160 ohms. Connect ohmmeter between both terminals. Reading should be 50-80 ohms. If switch does not respond as outlined in steps 3) and 4), replace thermo time switch.

### Volkswagen

1) With engine cold and air temperature below 68°F (20°C), disconnect electrical connector from cold start injector and connect test lamp to connector terminals. Disconnect electrical connector from No. 1 ignition coil terminal.

2) Operate starter. Test lamp should glow brightly. After 11 seconds (maximum), test lamp should dim or go out. If not, replace thermo time switch.

### COLD START INJECTOR

**NOTE:** Testing procedures not available for Porsche or Renault models.

### BMW

1) Remove cold start injector. Connect lead 61 1 440 to cold start injector between terminal "B+" and ground. Place container under injector.

2) Pull off relay 1. Connect 87 on relay socket with B+. Cold start injector should spray fuel. If not, replace injector.

### Fiat

1) Release fuel system pressure and remove cold start injector from intake manifold without removing fuel lines or electrical connector. Place injector in container.

2) Turn ignition on and crank engine. With engine coolant temperature below 95°F (35°C), fuel should be sprayed for 1-8 seconds. Above 95°F (35°C), no fuel should be sprayed.

3) If injector sprays continuously, drips or does not spray fuel as outlined, replace cold start injector.

### Volkswagen

1) Connect fuel gauge to fuel ring on top of cold start injector. Briefly operate starter until fuel pressure is present. Disconnect electrical connector from injector. Using 2 jumper wires, apply battery power to injector. Fuel pressure should drop slowly. If not, replace cold start injector.

2) Remove fuel gauge from injector and reconnect fuel line. Remove cold start injector from intake manifold with fuel line connected. Disconnect electrical connectors from injector and No. 1 terminal on ignition

coil. Operate starter. Injector should not leak. If injector leaks, replace cold start injector.

### COOLANT TEMPERATURE SENSOR

#### All Models

1) Warm engine to normal operating temperature and stop engine. Using a thermometer, measure temperature of coolant (oil on Volkswagen models). Disconnect electrical connector from temperature sensor and connect 1 lead of ohmmeter to terminal in sensor and other lead to ground. Ohmmeter readings should be as specified in table. If not, replace temperature sensor.

2) On Volkswagen models, if resistance reading is too high, touch ground lead of ohmmeter to sensor body. If resistance is as specified in table, corrosion is present between sensor and cylinder head. If resistance is still not as specified, replace temperature sensor.

### TEMPERATURE/RESISTANCE RELATIONSHIP

Temperature	Resistance (Ohms)
14°F (-10°C) .....	7,000-12,000
68°F (20°C) .....	2,000-3,000
176°F (80°C) .....	200-400

### FIAT TURBO ACCESSORIES FIAT SPIDER 2000 TURBO ONLY

**CAUTION:** Do not exceed 12 psi (.84 kg/cm<sup>2</sup>) air pressure during any test.

#### Boost Enrichment Switches

1) Disconnect vacuum hoses from "Y" fittings. Connect an air pressure regulator with pressure gauge attached to "Y" fitting. Disconnect boost enrichment electrical connectors. See Fig. 13.

2) Connect an ohmmeter to boost enrichment electrical connector terminals 1 and 2. Slowly apply air

**Fig. 13: Testing Fiat Spider 2000 Turbo Boost Enrichment Switches**

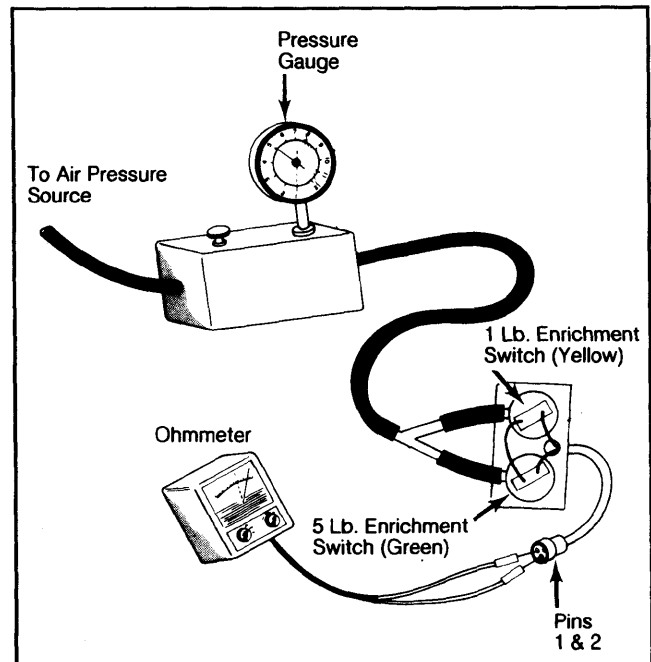

## BOSCH AFC — EUROPEAN MODELS (Cont.)

pressure to regulator and check that switch makes an audible click at 0.5-1.5 psi (0.04-0.11 kg/cm<sup>2</sup>). Ohmmeter should read 1500-2000 ohms.

3) Slowly increase pressure and check that other switch makes an audible click at 4.5-5.5 psi (0.32-0.39 kg/cm<sup>2</sup>). Ohmmeter should read 1750-2750 ohms. If not, replace boost enrichment switches.

**NOTE:** The 1 lb. enrichment switch is color coded Yellow and the 5 lb. enrichment switch is color coded Green.

### Load Enrichment Switch

1) Disconnect vacuum hoses from "Y" fittings and connect an air pressure regulator with pressure gauge attached to "Y" fitting. Disconnect load enrichment switch electrical connector. See Fig. 14.

2) Connect an ohmmeter to load enrichment electrical connector terminals 1 and 3. Zero ohmmeter. Ohmmeter should give infinity reading. Slowly apply air pressure to regulator and check that switch makes an audible click at about 1 psi (.07 kg/cm<sup>2</sup>) and ohmmeter reads 0 ohms. If not, replace load enrichment switch (color coded Blue).

**Fig. 14: Testing Fiat Spider 2000 Turbo Load Enrichment Switch**

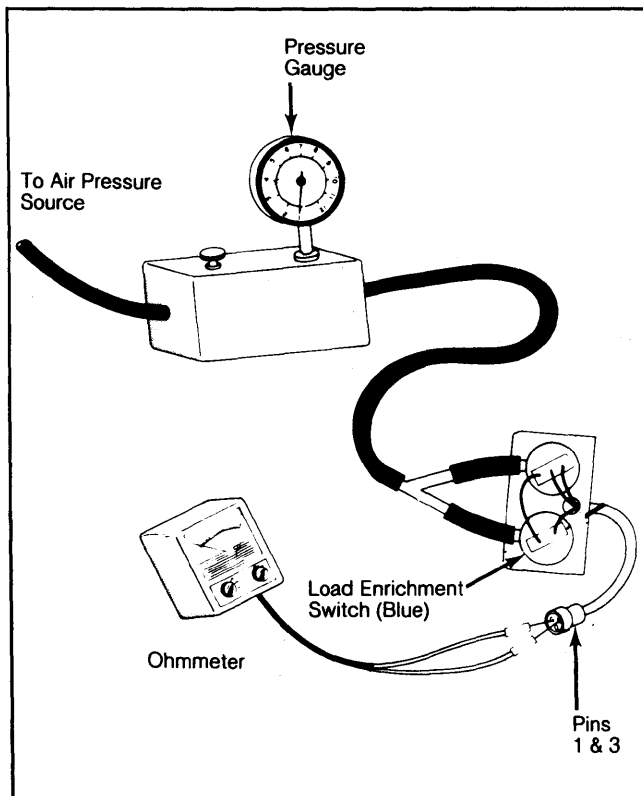

### Overboost Protection Switch

1) With air pressure regulator still connected to "Y" connector, move ohmmeter leads to electrical connector terminals 1 and 2. Ohmmeter should give an infinity reading. See Fig. 15.

2) Slowly apply air pressure to regulator and check that switch makes an audible click at about 9 psi (.63 kg/cm<sup>2</sup>) and ohmmeter reads 0 ohms. If not, replace overboost protection switch (color coded Black).

**Fig. 15: Testing Fiat Spider 2000 Turbo Overboost Protection Switch**

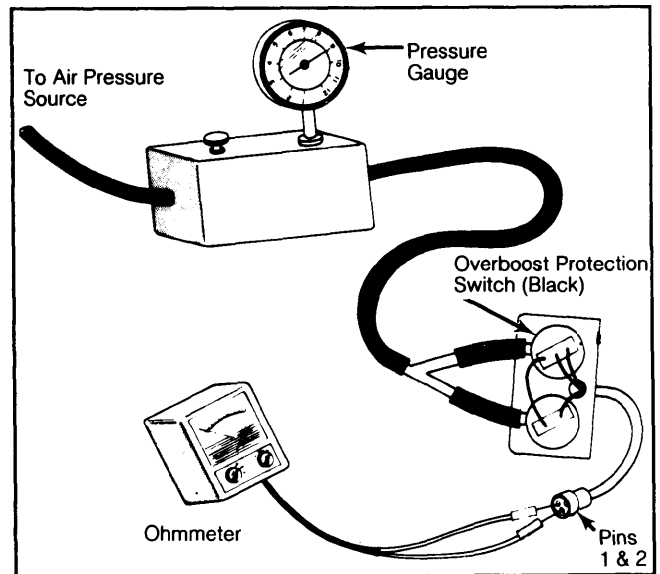

### SPEED LIMIT SWITCH CALIF. VOLKSWAGEN MODELS

Remove speed limit switch from firewall and connect positive voltmeter lead to terminal 8 and negative voltmeter lead to terminal 6. Start engine and accelerate to 3000 RPM. Voltmeter should indicate battery voltage. If not, replace speed limit switch.

**Fig. 16: Testing Speed Limit Switch**

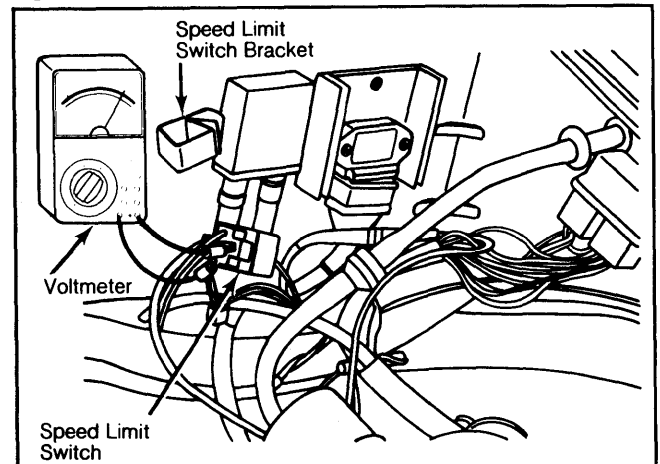

Calif. Volkswagen models.

## REMOVAL & INSTALLATION

**NOTE:** The Bosch AFC fuel injection system maintains constant fuel pressure in fuel lines and component parts at all times. Be sure to relieve pressure before attempting to open system at any point for removal or installation of components. Do not allow fuel to flow onto engine or electrical parts and do not allow open flame or sparks in area while servicing fuel system components.

# 1982 Fuel Injection

## BOSCH AFC — EUROPEAN MODELS (Cont.)

### ELECTRONIC CONTROL UNIT

1) Disconnect battery ground cable. On Renault models, remove passenger seat and fold back carpet. On all models, disconnect electrical connector retaining clamps or press back on clip located on wire end of connector.

2) Disconnect electrical connector, swinging to right if necessary to remove. Remove ECU retaining screws and remove ECU: To install, reverse removal procedure. ECU is located as follows:

- BMW 528e & 633CSi — Glove compartment.
- BMW 733i — Right kick panel, behind speaker.
- Fiat — Under dash on right side.
- Porsche 944 — Under dash.
- Porsche 928 — Right kick panel.
- Renault — Under carpet under passenger seat.
- Volkswagen — Right side of engine compartment.

### AIR FLOW METER

**NOTE:** Removal and installation procedures not available for Porsche or Volkswagen models.

#### BMW

Unscrew hose clamp. Remove cover attaching nuts. Pull out plug for electrical connectors. Pull air flow meter out of air cleaner housing and remove. To install, reverse removal procedure.

#### Fiat

1) Disconnect battery ground cable and air flow meter electrical connector. Remove air hoses from both sides of air flow meter. Remove mounting clamp bolt and washer from top of meter, then remove clamp.

2) From under meter, remove spacer and bushing. Remove 2 bolts, lock washers, plain washers and bushings securing meter to bracket. Remove air flow meter.

3) To install, reverse removal procedure. Make sure rubber bushing is installed under air flow meter and air hose connections are tight.

#### Renault

Disconnect battery ground cable. Disconnect electrical connector from air flow meter. Separate air hoses from air flow meter. Unclip retaining hook and remove air flow meter. To install, reverse removal procedure and ensure retaining hook is secured.

### THROTTLE SWITCH

Disconnect battery ground cable. Disconnect throttle switch electrical connector. Remove 2 screws securing throttle switch to housing. Remove switch by slowly pulling switch off throttle shaft. To install, reverse removal procedure. Make sure switch is aligned on throttle shaft and after replacement perform throttle switch adjustment. See *Adjustments in this article*.

### COLD START INJECTOR

Disconnect battery ground cable and remove electrical connector from cold start injector. Release fuel system pressure and remove fuel supply line from injector. Remove injector retaining bolts and remove injector. To install, reverse removal procedures.

### AUXILIARY AIR VALVE

**NOTE:** Replacement of auxiliary air valve requires that immediate replacement be available or

draining cooling system (oil on Volkswagen models) below level of valve.

Disconnect battery ground cable and remove electrical connector from air valve. Remove air hoses from valve. Remove 2 bolts securing valve to cylinder head and remove valve. To install, reverse removal procedure.

### COOLANT TEMPERATURE SENSOR

**NOTE:** Replacement of temperature sensor should be done only when engine is cold. Removal of sensor requires having replacement sensor ready for immediate installation or draining cooling system below level of sensor (oil on Volkswagen models).

Disconnect battery ground cable. Drain coolant as required and disconnect electrical connector from sensor. Loosen and remove sensor. To install, reverse removal procedure using sealer on threads of sensor. Replace sealing washers (if equipped).

### THERMO TIME SWITCH

**NOTE:** Thermo time switch removal should be done only when engine is cold. Removal of switch requires having replacement switch ready for immediate installation or draining cooling system (oil on Volkswagen models) below level of switch.

Disconnect battery ground cable and drain cooling system as required. Disconnect electrical connector from switch. Loosen and remove switch. To install, reverse removal procedure, using sealer on switch threads.

### FUEL PRESSURE REGULATOR

Disconnect battery ground cable and relieve fuel system pressure. Disconnect fuel lines and vacuum line at regulator. Remove pressure regulator, separating from bracket (if installed). To install, reverse removal procedure.

### FUEL INJECTORS

**NOTE:** Removal and installation procedures not available for Porsche or Volkswagen models.

#### BMW

1) Disconnect battery ground cable and relieve fuel system pressure. Unscrew mounting bolts of injection tube. Push up injection tube until injectors have been taken out of guide on intake manifold.

2) Pull off electrical plug on fuel injector. Lift off lock from injector and pull injector out of injection tube. To install, reverse removal procedure, replacing seals.

#### Fiat X1/9

1) Disconnect battery ground cable and relieve fuel system pressure. Disconnect fuel supply line from fuel rail, fuel return line from pressure regulator, vacuum hose from pressure regulator, fuel supply line from cold start injector and main air supply hose from throttle housing.

2) Disconnect accelerator cable from linkage, electrical connectors for throttle switch and cold start injector, auxiliary air valve hose from intake manifold and crankcase evaporative by-pass hose from intake manifold.

# 1982 Fuel Injection

## BOSCH AFC — EUROPEAN MODELS (Cont.)

Fig. 17: BMW AFC Fuel Injection Wiring Diagram

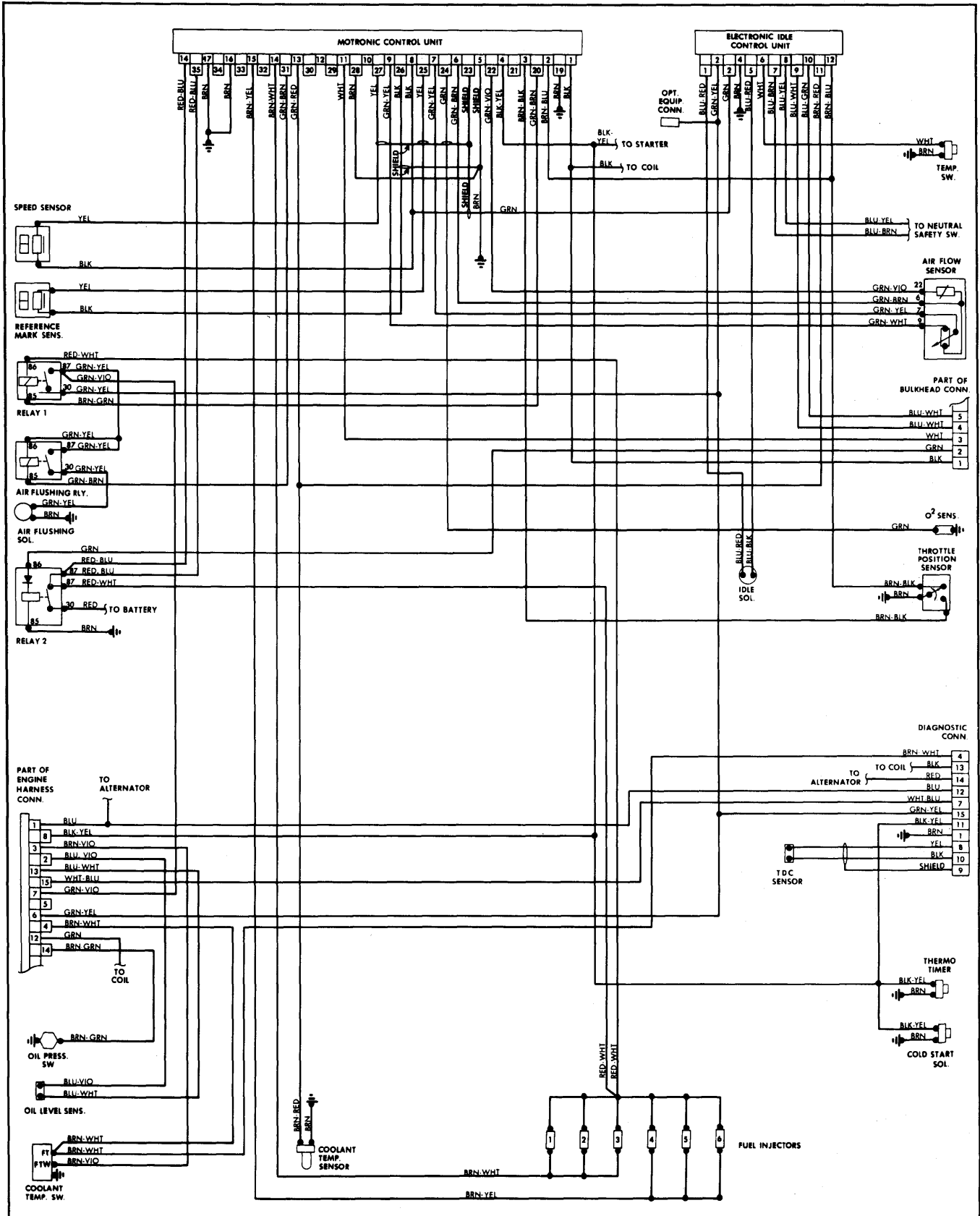

# 1982 Fuel Injection

## BOSCH AFC — EUROPEAN MODELS (Cont.)

Fig. 18: Fiat AFC Fuel Injection Wiring Diagram

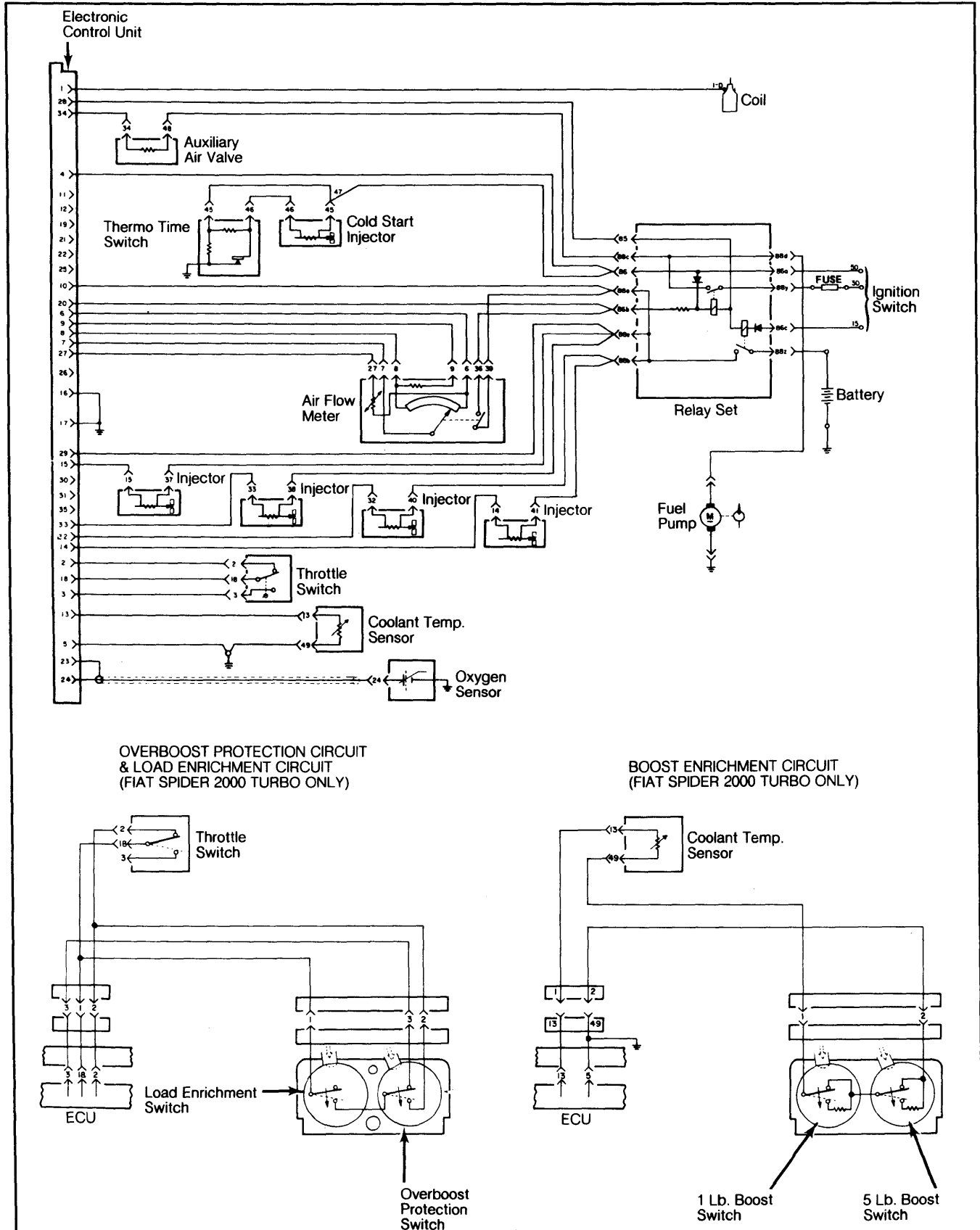

## BOSCH AFC — EUROPEAN MODELS (Cont.)

Remove 2 intake manifold cooling air duct retaining nuts and washers. Disconnect cooling air hose from duct and remove duct.

3) Remove nuts and washers holding air intake to manifold. Carefully lift air intake off manifold studs and tilt air intake backwards. Disconnect electrical connectors from injectors.

4) Remove 2 bolts and washers holding fuel injectors in intake manifold. Remove injectors and adapters from fuel rail, being careful not to damage bushings and "O" rings on injectors and adapters. Remove fuel rail. Remove small and large rubber bushings from injectors.

5) Remove retainers from injectors and "O" rings from adapters. Replace defective injectors using new hose. To install, reverse removal procedure. Be sure to replace "O" rings on adapters and large and small rubber bushings on injectors.

### Fiat Spider 2000 & Spider 2000 Turbo

1) Disconnect battery ground cable and relieve fuel system pressure. Disconnect electrical connectors at all injectors. Remove fuel supply hose from fuel rail, fuel return line from pressure regulator, fuel line from cold start injector and vacuum line from pressure regulator.

2) Remove fuel rail mounting bolts and 4 injector retaining nuts. Remove fuel rail, injectors and pressure regulator as an assembly. Remove injectors from fuel rail by pulling off fuel hoses. To install, reverse removal procedure.

### Renault

1) Disconnect battery ground cable and relieve fuel system pressure. Remove injector retaining bolts. Disconnect fuel lines and electrical connectors. Remove fuel rail with injectors attached. Remove injector seals.

2) Remove injectors from fuel rail by melting hose lengthwise with a soldering gun until injector can be removed from fuel rail. Thoroughly clean fuel rail assembly of rubber.

3) To install, reverse removal procedure. Install injector on fuel rail with new hose and ensure hose is fully seated on injector and fuel rail. Connect hose with a clamp. Ensure injector seals are installed.

## ADJUSTMENTS

**NOTE:** For all on-vehicle adjustments not covered in this article, see appropriate TUNE-UP SERVICE PROCEDURES article.

### Fiat

1) Before adjusting throttle switch, ensure engine speed is set to specifications. With engine off, remove electrical connector from throttle switch, loosen 2 screws and connect an ohmmeter between terminals 18 (center) and 2 (right of center).

2) Rotate switch clockwise until ohmmeter reading is 0 ohms. Tighten mounting screws at point ohmmeter reading registers 0 ohms. If throttle switch cannot be adjusted as described, replace switch.

### Porsche 944

To adjust throttle switch, move the throttle against idle stop. Unscrew throttle switch screws and turn throttle switch until idle contact closes. Tighten screws. When properly adjusted, idle contact will open at a 1° angle as throttle is opened.

Fig. 19: Renault 18i AFC Fuel Injection Wiring Diagram (Fuego Similar)

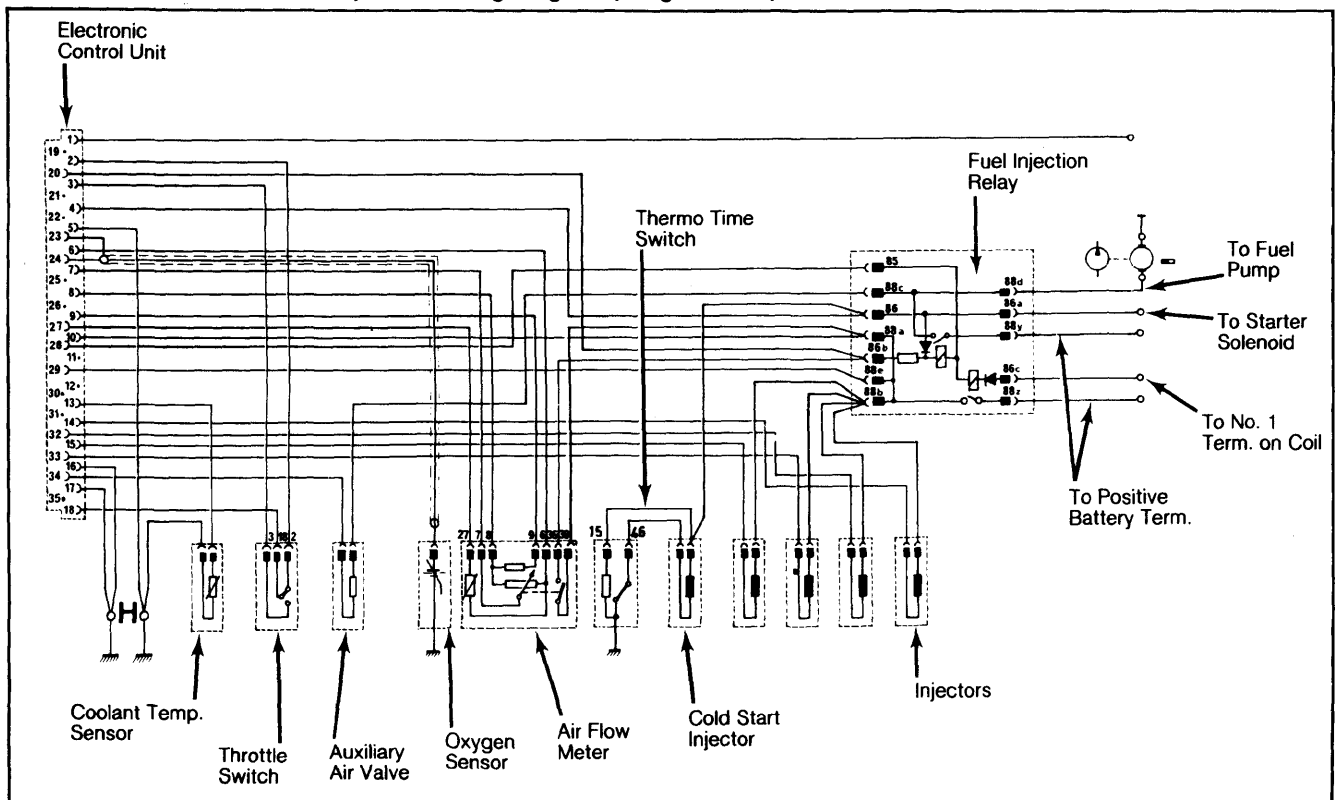

# 1982 Fuel Injection

## BOSCH AFC — EUROPEAN MODELS (Cont.)

### Renault

With the throttle plate against its idle stop, slowly rotate the throttle switch in the direction of throttle plate opening until the inner stop can be felt. Tighten the fixing screws.

### Volkswagen

1) Disconnect electrical connector at throttle switch. Zero ohmmeter and connect ohmmeter leads to both terminals on switch. With throttle valve closed, ohmmeter reading should register infinity reading. Slowly

open throttle valve. Just before reaching stop, ohmmeter reading should register 0 ohms.

2) If switch does not respond as outlined in step 1), fully depress accelerator pedal and hold in position. Loosen throttle switch and move switch until ohmmeter reading changes from infinity reading to 0 ohms and tighten switch. Roller of switch should be centered on curved arm of throttle lever. If switch cannot be adjusted as described, replace throttle switch.

Fig. 20: Volkswagen AFC Fuel Injection Wiring Diagram

