

## TYF SINGLE BARREL

Subaru 1.8L, Volkswagen Rabbit 1.7L,

### DESCRIPTION

TYF carburetor is a single barrel down draft type consisting of five systems which enable it to provide correct fuel/air ratio under various operating conditions and loads. It also incorporates a pulsing air control solenoid allowing it to interface with an electronic feedback fuel control system. The five systems are:

- Float Circuit System
- Low-Speed System
- High-Speed System
- Accelerating Pump System
- Choke System

The basic purpose of feedback control is to provide a narrow air/fuel ratio band so that the catalytic converter will operate at maximum efficiency.

### ADJUSTMENTS

**NOTE:** For all on-vehicle adjustments not covered in this article, see the appropriate TUNE-UP SERVICE PROCEDURES article.

#### FLOAT TRAVEL

##### Float Level

1) Remove air horn and detach air horn gasket. Position float at air horn. Invert air horn to free float. At this point, measure the distance shown in Fig. 1.

**Fig. 1: Float Adjustment Being Made With Air Horn Inverted**

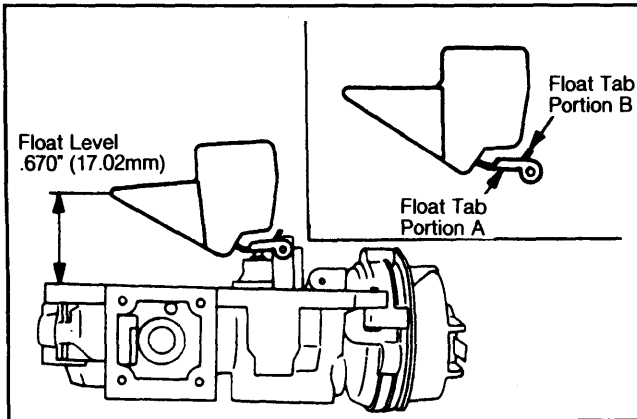

Bend tab portion "A" to adjust float to proper height.

2) If distance is outside specifications of .670" (17.02 mm). Bend tab portion "A" to adjust distance. After distance has been adjusted properly, turn air horn right side up to lower float.

##### Float Drop

To adjust float drop, place air horn in an upright position, the distance between top of float at notch on outer end of float and bowl cover should be 1½" (38 mm). Adjust by bending stop tab "B" on float lever. See Fig. 1.

#### ENGINE OFF THROTTLE STOP SCREW

Turn adjusting screw clockwise until it just contacts throttle lever, continue 1 complete turn. This

adjustment should be made before pump and metering rod adjustment.

#### ACCELERATOR PUMP

1) Remove carburetor air horn. Remove plug from air horn. Remove float, needle, lifting link and metering rod. Reinstall carburetor air horn.

2) Hold carburetor in vise at idle screw boss. Place dial indicator with 40 mm extension over pump plunger. Measure travel from full closed to full open throttle. Plunger travel should be .265" (6.7 mm).

3) To adjust pump stroke, bend connecting rod at lower bend. Lengthening the rod will increase pump stroke, shortening the rod will decrease pump stroke. Remove carburetor air horn, reinstall float and metering rod.

**NOTE:** Metering rod must always be checked and adjusted after adjusting pump stroke.

#### METERING ROD

1) Remove air horn from carburetor and remove tamper resistant plug over metering rod. Reinstall air horn.

2) Use a dial indicator or gauge through hole in air horn. Pushing metering rod downward to its bottomed position, measure distance from air horn to top of metering rod adjusting screw. With throttle closed and metering rod spring lifting rod to its upper position, the amount of lift from bottomed position should be .050" (1.3 mm).

3) To adjust, rotate adjusting screw with a torx head, T-9 driver. After adjustment install tamper resistant plug.

#### AUTOMATIC CHOKE

The choke valve is linked to the bimetal housing through the choke lever. The choke valve is kept opened at the degree corresponding to the ambient temperature by means of the bimetal force. Bimetal housing is set at 1 notch to rich side, as marked on choke housing (10 degrees per notch).

**Fig. 2: Checking and Adjusting Choke Cam Index**

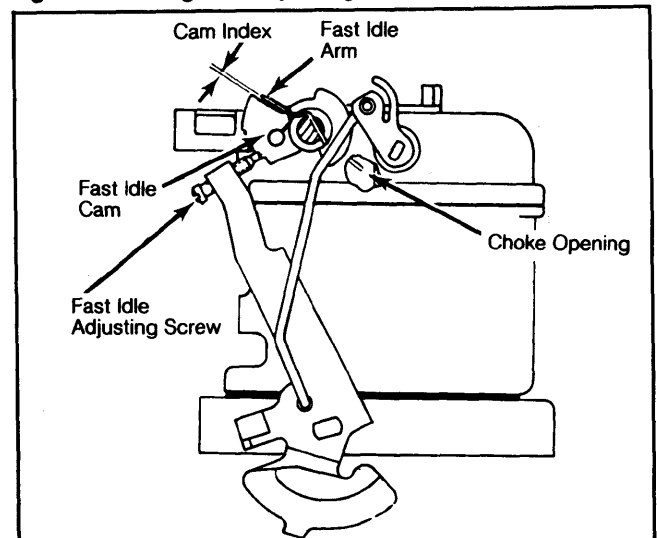

If necessary, adjust by bending fast idle arm.

# 1982 Carter-Weber Carburetors

## TYF SINGLE BARREL (Cont.)

### CHOKE CAM INDEX

1) Set adjusting screw for fast idle speed on the 4th step of fast idle cam. Apply vacuum to pull down diaphragm. A gap less than .039" (1 mm) should exist between fast idle arm and fast idle cam.

2) If necessary, adjust by bending fast idle arm.

### CHOKE UNLOADER

Hold throttle valve in wide open position and close choke valve as far as possible without forcing. There should be .152" (3.8 mm) clearance between lower edge of choke valve and inner wall of air horn. Adjust by bending tab.

### CHOKE PULL-DOWN

1) Set adjusting screw for fast idle speed on top step of fast idle cam. Connect manually operated vacuum pump to pull down unit and build up vacuum.

2) Close choke valve slightly by pressing gently. Check gap between bottom of choke plate and air horn, gap should be .152" (3.8 mm). Adjust gap at adjustment screw on pull down unit. After adjustment, seal screw with sealant.

### FAST IDLE (ON VEHICLE)

With fast idle screw on 2nd step, adjust fast idle screw to 2800-3200 RPM.

### IDLE SOLENOID

With engine running and solenoid activated, adjust hex nut on solenoid plunger to 820-900 RPM.

### SOLEVAC

#### Models With Air Conditioning

Turn on air conditioner to energize vacuum section of solevac. Adjust to 820-900 RPM with screw on lever.

Fig. 3: Exploded View of the Carter-Weber TYF Carburetor

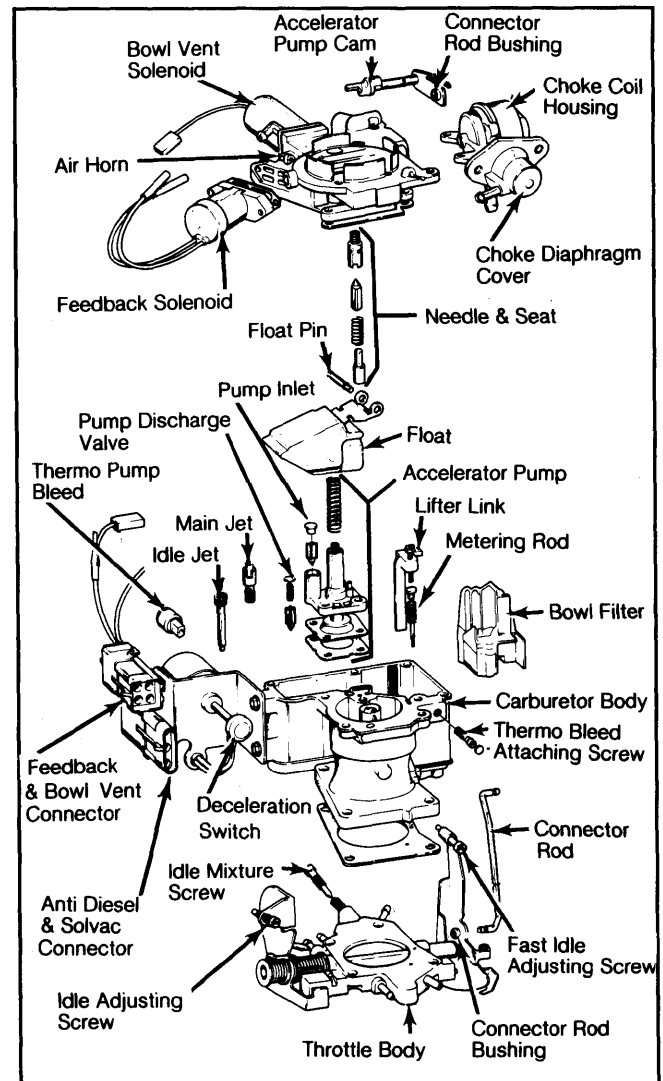

### CARBURETOR ADJUSTMENT SPECIFICATIONS

Application	Float Level	Choke Unloader	Choke Pull-Down	Fast Idle	Auto. Choke
Subaru & Volkswagen Rabbit	.670" (17.02 mm)	.152" (3.8 mm)	.152" (3.8 mm)	2800-3200 ....	1 Notch (10°)