

## AISAN 2-BARREL — TOYOTA 2F ENGINE

Land Cruiser

### DESCRIPTION

Carburetor is a 2-barrel, down draft type with vacuum operated choke breaker to improve cold engine operation. A secondary slow port helps fuel mixing at start of secondary valve opening. Improvement of operation is noticed during low speed load. A piston type accelerator pump is incorporated into the primary barrel.

Other equipment includes a diaphragm to open secondary valve at high speed and full throttle operation. A throttle stop solenoid is also used to prevent dieseling during engine shut down.

### CARBURETOR IDENTIFICATION

Application	Carb. No.
All Models .....	21100-61141

### ADJUSTMENTS

**NOTE:** For all on-vehicle adjustments not covered in this article, see appropriate TUNE-UP SERVICE PROCEDURES article.

**NOTE:** It is recommended that Toyota carburetor adjusting kits 09240-00014 and 09240-00020 be used to make the following adjustments.

#### FLOAT LEVEL

Turn air horn assembly upside-down. Measure clearance between upper surface of float and gasket surface of air horn. Bend center float tab until float level is correct. See Fig. 1.

Fig. 1: Float Level Adjustment

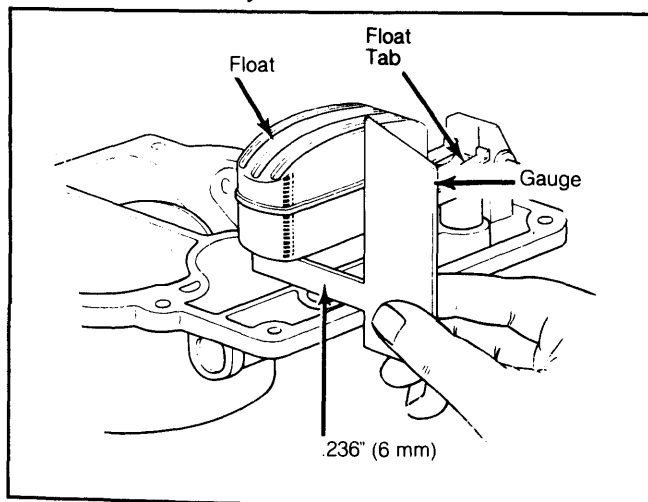

Adjust by bending float tab.

#### FLOAT DROP

Lift up float assembly and measure clearance between needle valve plunger and float lip. Adjust clearance to specification by bending both outside float tabs. See Fig. 2.

Fig. 2: Float Drop Adjustment

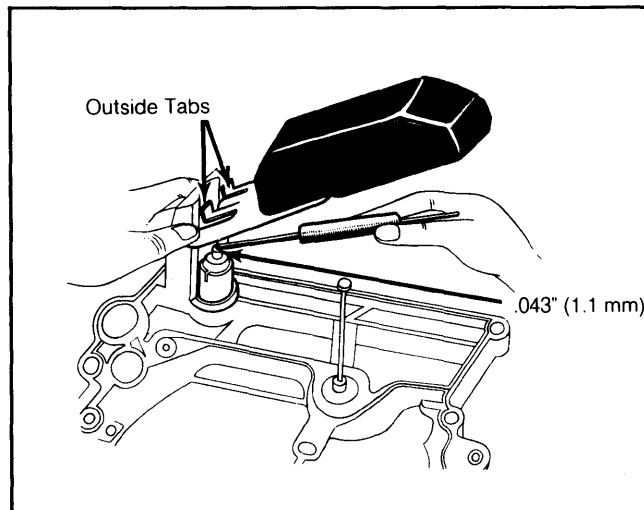

Adjust by bending both outside float tabs.

#### PRIMARY & SECONDARY THROTTLE VALVES

Open primary throttle valve. Then open secondary throttle valve. Make sure valves are perpendicular to flange surface when fully opened. Bend throttle lever stopper(s) until proper opening is obtained.

#### FAST IDLE (BENCH ADJUSTMENT)

Fully close choke valve. Check clearance between throttle bore and primary throttle valve. Adjust clearance to .051 inch (1.3 mm) by turning fast idle adjusting screw. See Fig. 3.

Fig. 3: Fast Idle Adjustment

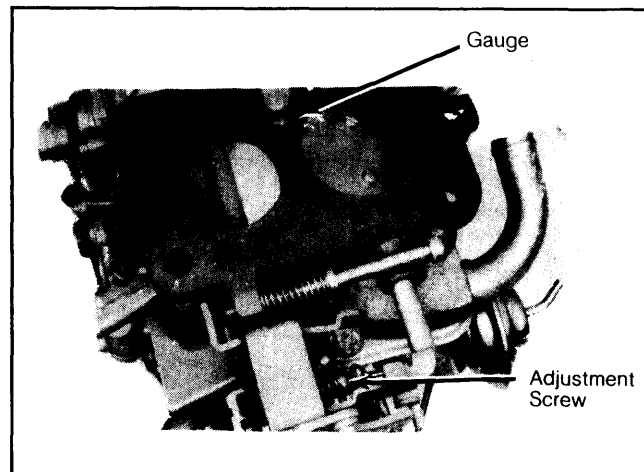

Adjust by turning fast idle adjusting screw.

#### CHOKE BREAKER ADJUSTMENT

1) Apply vacuum to choke breaker diaphragm. Insert angle gauge. While closing choke valve by hand, check choke valve angle.

2) Set choke valve angle to 45° by bending choke breaker link at existing bend. After adjustment, ensure smooth operation of choke valve. See Fig. 4.

# 1982 Aisan Carburetors

## AISAN 2-BARREL — TOYOTA 2F ENGINE (Cont.)

**Fig. 4: Choke Breaker Adjustment**

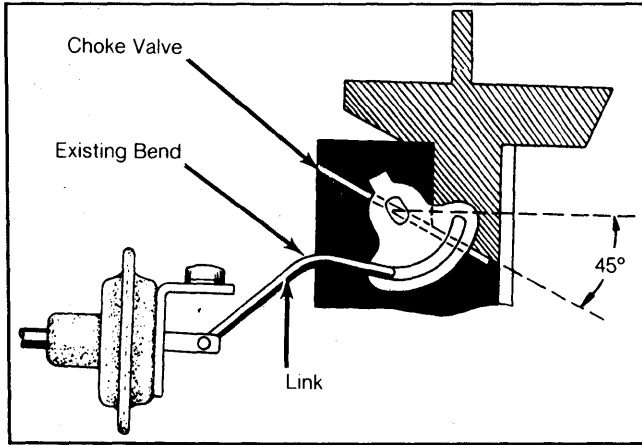

Adjust by bending link at existing bend.

### CHOKE OPENER

Close choke valve by turning choke shaft lever. Apply vacuum to diaphragm. Insert angle gauge. Bend choke shaft stopper to obtain 75° angle between choke valve and bore. See Fig. 5.

**Fig. 5: Choke Opener Adjustment**

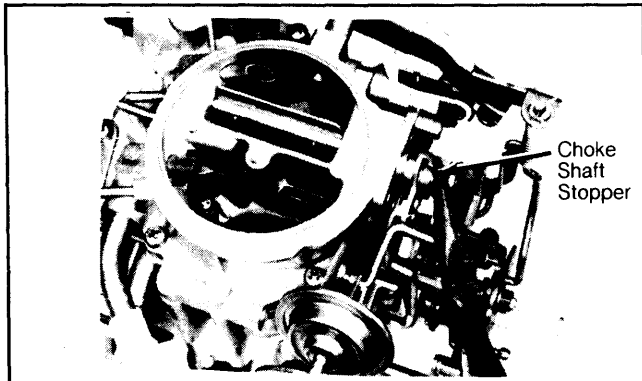

Bend choke shaft stopper to adjust.

### CHOKE UNLOADER

Open primary throttle valve. Insert angle gauge. Bend primary throttle arm to obtain 50° angle between choke valve and bore. See Fig. 6.

**Fig. 6: Choke Unloader & Secondary Touch Adjustment**

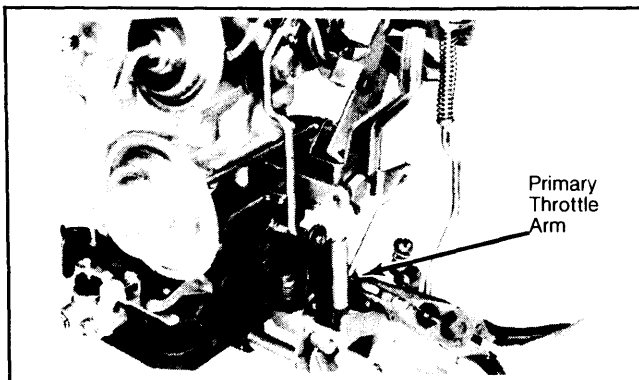

Bend primary throttle arm to adjust.

### SECONDARY TOUCH ANGLE

Insert angle gauge into primary throttle valve opening at the same time the secondary throttle valve starts to open. Bend primary throttle arm to obtain 67° angle between primary throttle valve and bore. See Fig. 6.

### SLOW CUT VALVE

Set primary throttle valve opening to secondary touch angle (67°). Adjust slow cut valve stroke to .059-.079" (1.5-2.0 mm) by bending lever shown in Fig. 7.

**Fig. 7: Slow Cut Valve Adjustment**

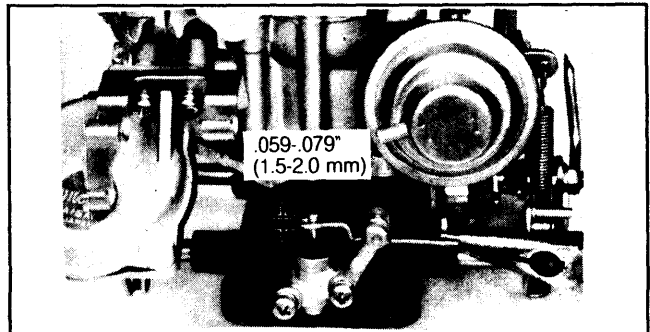

Bend lever to adjust.

### SECONDARY THROTTLE OPENING ANGLE (KICK-UP)

Bend secondary throttle lever to obtain 25° angle between secondary throttle valve and bore when primary valve is fully open. See Fig. 8.

**Fig. 8: Secondary Throttle Opening Angle (Kick-Up) Adjustment**

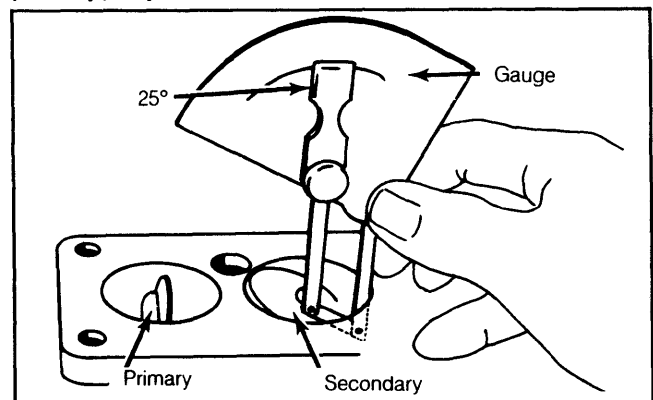

Bend secondary throttle lever to adjust.

## OVERHAUL

### DISASSEMBLY

**NOTE:** It is recommended that Toyota carburetor driver kit 09860-11011 be used during carburetor overhaul.

#### Air Horn

1) Remove pump connecting link, pump arm and fast idle connecting link. Remove choke breaker connecting link and choke breaker.

## AISAN 2-BARREL — TOYOTA 2F ENGINE (Cont.)

2) Remove screws securing air horn to carburetor body and carefully lift off air horn assembly. See Fig. 9.

**Fig. 9: Exploded View of Carburetor Air Horn**

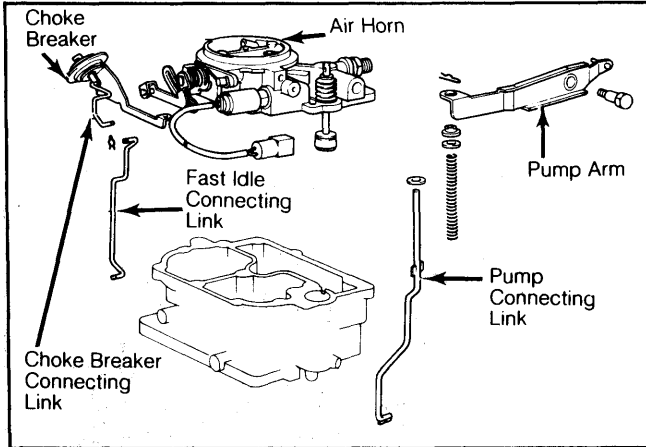

### Float Assembly

1) Remove solenoid valve, pump plunger, boot, float lever pin and float. Remove air horn gasket, needle valve, spring and pin.

2) Using driver, remove needle valve seat by turning counterclockwise. Remove power piston retainer, power piston and spring. See Fig. 10.

**Fig. 10: Exploded View of Carburetor Float Parts**

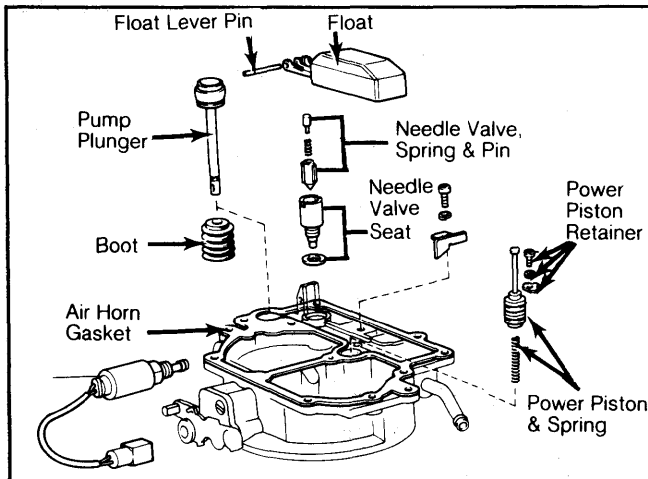

### Choke System

File off ends of choke valve set screws and remove choke valve. Unhook choke valve relief spring. Pull out choke shaft. See Fig. 11.

**Fig. 11: Exploded View of Carburetor Choke Assembly**

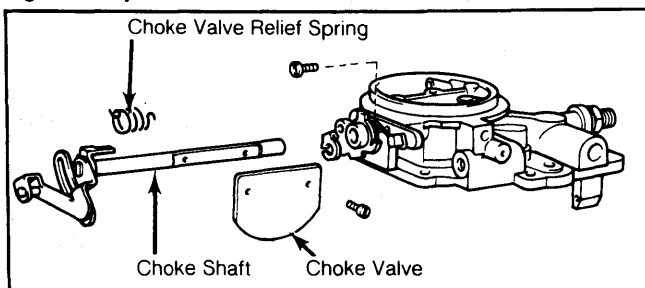

### Main Body

1) Remove discharge weight, spring, steel ball, and pump damping spring. Using tweezers, remove check ball retainer, then remove steel ball for pump plunger.

2) Using driver, remove 1st and 2nd slow jets, and power valve by turning counterclockwise, then remove 1st and 2nd main jets. Remove small venturi, sight gauge glass, and diaphragm.

3) Remove choke wire clamp, back spring for throttle shaft, choke opener connecting arm and choke opener. See Fig. 12.

**Fig. 12: Exploded View of Carburetor Main Body**

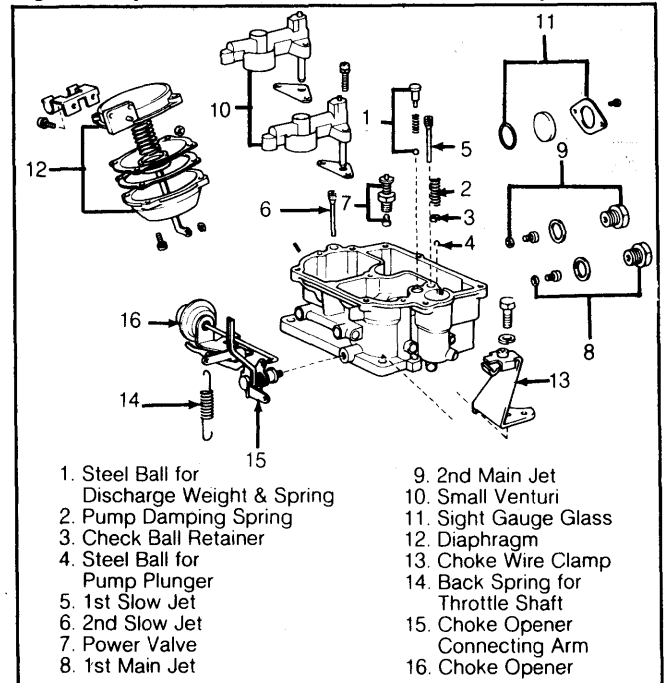

### Flange Parts

Using driver, remove vacuum passage bolt by turning counterclockwise. Remove slow cut valve. See Fig. 13.

**Fig. 13: Exploded View of Carburetor Flange Parts**

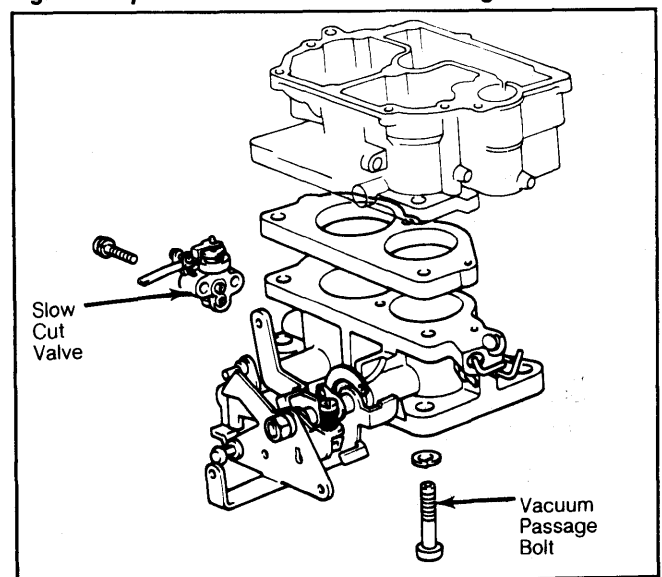

# 1982 Aisan Carburetors

## AISAN 2-BARREL — TOYOTA 2F ENGINE (Cont.)

### CLEANING & INSPECTION

Clean all parts in carburetor cleaner and blow dry. Do not attempt to clean jets or other passages with wire or other metal objects. Inspect all parts for wear or damage and replace necessary parts.

### REASSEMBLY

Using new gaskets, reverse disassembly procedure and make note of the following:

1) When installing 1st and 2nd main jets, 1st jet is "brass" colored and 2nd jet is "chrome" colored.

2) When installing 1st and 2nd small venturies, 1st venturi is "chrome" colored and 2nd venturi is "brass" colored.

3) Select fast throttle shaft shim to obtain .004" (.1 mm) clearance. Shims are available in thicknesses of .004-.024" (.1-.6 mm).

4) When installing steel balls, make sure that smaller ball goes to pump plunger and larger ball goes to discharge weight.

5) After installing choke valve, stake the choke shaft screws. Using driver, install needle valve seat by turning clockwise.

### CARBURETOR ADJUSTMENT SPECIFICATIONS

Application	Float Level In. (mm)	Float Drop In. (mm)	Fast Idle Opening In. (mm)	Choke Breaker Angle	Accel. Pump Stroke In. (mm)	Slow Cut Valve Stroke In. (mm)
Land Cruiser	.236 (6)	.043 (1.1)	.051 (1.3)	45°	.374 (9.5)	.059-.079 (1.5-2.0)