

1982 Volvo V6 Tune-Up

TUNE-UP

GLE

ENGINE IDENTIFICATION

B28F engine identification number is stamped in lower left front corner of block above front cover of oil pan.

ENGINE COMPRESSION

Check compression with engine at normal operating temperature, spark plugs removed, throttle valve wide open and at normal cranking speed (250-300 RPM). Crank engine at least 6 "puffs" per cylinder.

COMPRESSION SPECIFICATIONS

Compression Ratio	8.8:1
Compression Pressure	114-156 psi (8-11 kg/cm ²)

VALVE CLEARANCE

1) Adjust valves with engine cold. Rotate crankshaft so that No. 1 cylinder is at TDC of ignition stroke (both rocker arms for No. 1 cylinder have clearance).

NOTE: Crank pulley has 2 notches. When No. 1 cylinder is at TDC, upper notch will align with "0" notch on timing marker and lower crank pulley notch will be 150° counterclockwise from upper notch. (Second notch is TDC for No. 6 cylinder when aligned with "0" on timing marker).

2) Adjust intake valves of cylinder Nos. 1, 2 and 4, and exhaust valves of cylinder Nos. 1, 3 and 6. Rotate crankshaft 360°. This will set No. 1 cylinder at TDC of exhaust stroke (rocker arms for No. 1 cylinder with no clearance). Adjust intake valves of cylinder Nos. 3, 5 and 6, and exhaust valves of cylinder Nos. 2, 4 and 5.

VALVE CLEARANCE SPECIFICATIONS

Application	Intake In. (mm)	Exhaust In. (mm)
All Models004-.006 (.10-.15)	.010-.012 (.25-.30)

VALVE ARRANGEMENT

Right Bank — E-I-E-I-E-I (Front to rear)
Left Bank — I-E-I-E-I-E (Front to rear)

SPARK PLUGS

SPARK PLUG TYPE

Application	Bosch No.
All Models	HR6DS

SPARK PLUG SPECIFICATIONS

Application	Gap In. (mm)	Torque Ft. Lbs. (N.m)
All Models030 (.75)	9 (12)

Fig. 1: Firing Order and Distributor Rotation

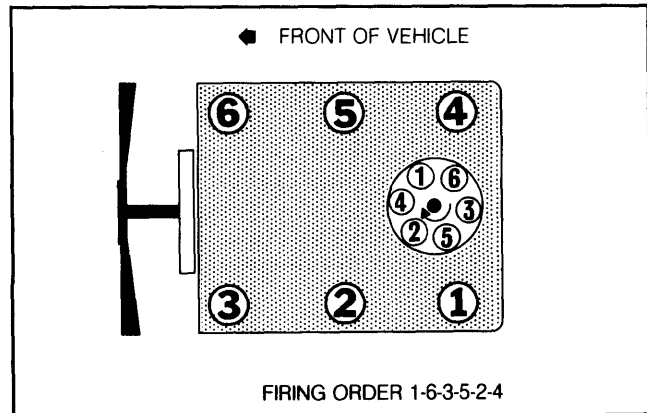

DISTRIBUTOR

All models are equipped with Bosch Electronic Ignition Systems. No adjustments are required.

IGNITION TIMING

Connect a timing light and tachometer. Remove and plug vacuum hose at distributor. With engine at normal operating temperature and idle RPM, rotate distributor to set timing. Reconnect distributor vacuum hose and remove test equipment.

IGNITION TIMING SPECIFICATIONS (Degrees BTDC@RPM)

Application	1 Timing
All Models	10@900

¹ — With distributor vacuum hose disconnected and plugged.

Fig. 2: Ignition Timing Mark Location

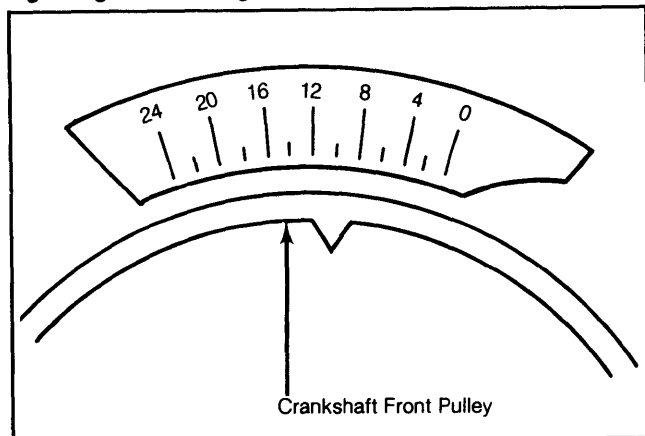

TUNE-UP (Cont.)

IDLE SPEED & MIXTURE

IDLE SPEED

All models are equipped with electronic idle speed control and no adjustments are possible.

IDLE MIXTURE

NOTE: Adjustment is not a normal tune-up procedure and should not be performed unless vehicle fails emission testing.

1) Remove mixture control unit and punch out mixture plug (steel ball) with a punch. Reinstall mixture control unit. Disconnect oxygen sensor.

2) Remove plugs from header pipes (1 for each cylinder bank) and connect CO probe to each pipe. Connect tachometer and start engine. Run engine until normal operating temperature is reached.

Fig. 3: CO Meter Installation

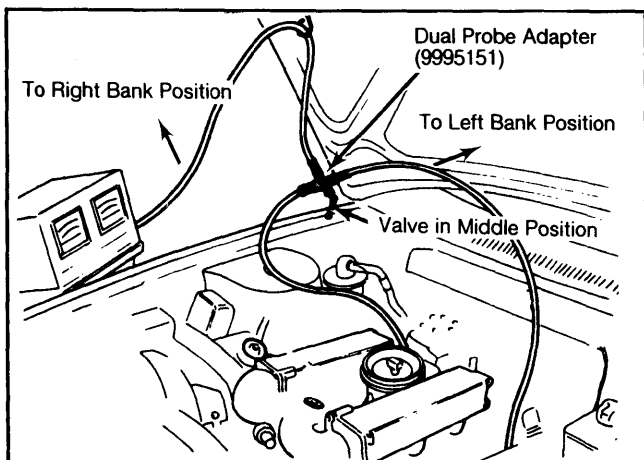

3) Turn dual probe adapter to center position.

In this position exhaust gases are admitted from both cylinder banks for total CO level reading. Read CO level. With CO meter and tachometer still attached, install air cleaner and connect hoses.

4) Insert adjusting wrench into hole in mixture control unit and adjust CO. After each adjustment, adjusting wrench must be removed and adjustment hole covered to prevent a lean mixture while checking CO level. See Fig. 4.

Fig. 4: Idle Mixture Adjustment

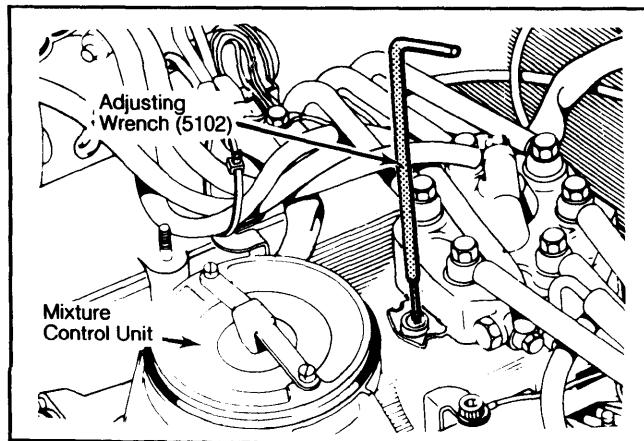

5) To check CO balance between left and right cylinder banks, turn dual probe adapter toward left cylinder bank and check CO reading. If left bank CO level is not within specifications, correct by removing balance screw plug and adjusting balance screw "2". See Fig. 5.

Fig. 5: Balance and Air Adjusting Screw Locations

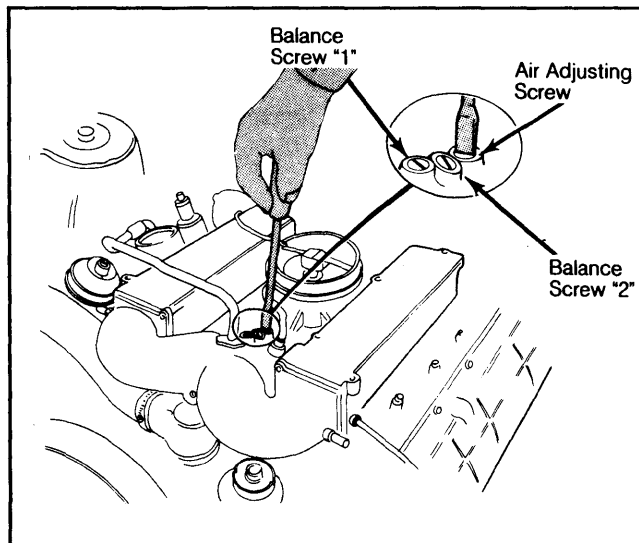

NOTE: CO reading should be equal for both banks and correct for the whole system.

6) Turn dual probe adapter toward right cylinder bank and check CO reading. If right bank CO level is not within specifications, correct by removing balance screw plug and adjusting balance screw "1".

NOTE: CO reading should be equal for both banks and correct for the whole system.

7) Recheck CO level with dual probe adapter in center position. If necessary, repeat adjustment procedure. Reconnect oxygen sensor electrical connector. Remove test equipment, insert exhaust pipe plugs and seal mixture adjustment hole.

IDLE SPEED & CO LEVEL

Application	Idle RPM	CO%
All Models	900	¹ 0.7-1.3

¹ — Oxygen sensor disconnected. With oxygen sensor connected, CO level should be below 1.0%.

FUEL PUMP

FUEL PUMP PERFORMANCE

Application	Pressure psi (kg/cm ²)	Volume in 30 sec. Pints (Liters)
All Models	64-75 (4.5-5.3)	1.7 (0.8)

EXHAUST EMISSION SYSTEMS

See EXHAUST EMISSION SYSTEMS section.

1982 Volvo V6 Tune-Up

GENERAL SERVICING

IGNITION

DISTRIBUTOR

All models are equipped with Bosch Electronic Ignition Systems. No adjustments are required.

FUEL SYSTEM

FUEL INJECTION

All models are equipped with Bosch Lambda CIS fuel injection system with oxygen sensor.

ELECTRICAL

BATTERY

BATTERY SPECIFICATIONS

Application	Amp. Hr. Rating
All Models	60

STARTER

All models are equipped with Bosch overrunning clutch starters.

STARTER SPECIFICATION

Application	Volts	Amps	Test RPM
All Models	11.5	30-50	5500-7500

ALTERNATOR

All models are equipped with Bosch alternators with integral voltage regulators.

ALTERNATOR SPECIFICATIONS

Application	Rated Amp. Output
All Models	70

ALTERNATOR REGULATOR

All models are equipped with Bosch alternator regulators, integral with alternator.

REGULATOR OPERATING VOLTAGE

Application	Voltage
All Models	13.0-15.0

SERVICE SPECIFICATIONS

BELT ADJUSTMENT

Application	¹ Deflection In. (mm)
All Belts2-.4 (5-10)

¹ — Deflection is measured with moderate thumb pressure applied at midpoint of longest belt run.

REPLACEMENT INTERVALS

Component	Miles
Oil Filter	7500
Air Filter	30,000
Fuel Filter	15,000
Fuel Tank Filter	60,000
PCV Valve	30,000
Spark Plugs	30,000
Oxygen Sensor	30,000

FLUID CAPACITIES

Application	Quantity
Crankcase (Including Filter)	4.0 qts. (3.8L)
Cooling System (Including Heater)	10.0 qts. (9.4L)
Auto. Trans. (ATF Type F)	14.6 pts. (6.9L)
Rear Axle (SAE 90)	3.4 pts. (1.6L)
Fuel Tank	15.8 gals. (60.0L)