

## TUNE-UP

DL, GL, GLT, GLT Turbo

### ENGINE IDENTIFICATION

Identification number for B21F type engine is stamped on left side of engine block near the distributor.

#### ENGINE CODE

| Application                     | Code    |
|---------------------------------|---------|
| CIS Engine                      |         |
| Man. Trans. ....                | 498-960 |
| Auto. Trans. ....               | 498-961 |
| LH-Jetronic Engine <sup>1</sup> |         |
| Man. Trans. ....                | 498-962 |
| Auto. Trans. ....               | 498-963 |
| Turbo .....                     | 498-898 |

<sup>1</sup> — Used on some 4-door and 5-door DL models.

### ENGINE COMPRESSION

Check compression with engine at normal operating temperature, all spark plugs removed, throttle valve wide open and at normal cranking speed (250-300 RPM). Crank engine at least 6 "puffs" per cylinder.

#### COMPRESSION SPECIFICATIONS

|                        |  |
|------------------------|--|
| Compression Ratio      |  |
| Turbo .....            | 7.5:1                                  |
| All Other Models ..... | 9.3:1                                  |
| Compression Pressure   |  |
| Turbo .....            | <sup>1</sup>                           |
| All Other Models ..... | 128-156 psi (9-11 kg/cm <sup>2</sup> ) |

<sup>1</sup> — Information not available from manufacturer.

### VALVE CLEARANCE

1) Valve clearance is adjusted with engine shut off and either warm or cold. Remove valve cover. Turn crankshaft center bolt until camshaft is in position for firing No. 1 cylinder. Both cam lobes should point up at equally large angles. Pulley timing mark should be at 0°.

2) Check valve clearance of No. 1 cylinder, using a feeler gauge between camshaft lobe and adjusting discs. Intake and exhaust valves have same clearance.

3) If clearances are incorrect adjust by changing thickness of discs, which are available in .002" (.05 mm) increments from .130" (3.30 mm) to .177" (4.50 mm). Use tools 5022 and 5026 to depress and remove disc.

#### VALVE CLEARANCE SPECIFICATIONS

| Application        | Cold<br>In. (mm)       | Hot<br>In. (mm)        |
|--------------------|------------------------|------------------------|
| Intake and Exhaust |                        |                        |
| Checking .....     | .012-.018<br>(.30-.45) | .014-.020<br>(.35-.50) |
| Setting .....      | .014-.016<br>(.35-.40) | .016-.018<br>(.40-.45) |

4) After valves for No. 1 cylinder are properly adjusted, rotate crankshaft to firing position for No. 3, No. 4 and No. 2 cylinders in sequence and complete adjustment.

### VALVE ARRANGEMENT

E-I-E-I-E-I-E-I (Front to rear)

### SPARK PLUGS

#### SPARK PLUG TYPE

| Application      | Bosch No. |
|------------------|-----------|
| All Models ..... | WR7DS     |

#### SPARK PLUG SPECIFICATIONS

| Application      | Gap<br>In. (mm) | Torque<br>Ft. Lbs. (N.m) |
|------------------|-----------------|--------------------------|
| All Models ..... | .030 (.75)      | 19 (26)                  |

### DISTRIBUTOR

All models except Turbo are equipped with a Volvo Breakerless Ignition System, featuring computer controlled spark advance and a Hall Effect distributor. The Turbo is equipped with a Bosch Electronic Ignition System. For both systems, no adjustments are required.

Fig. 1: Firing Order and Distributor Rotation

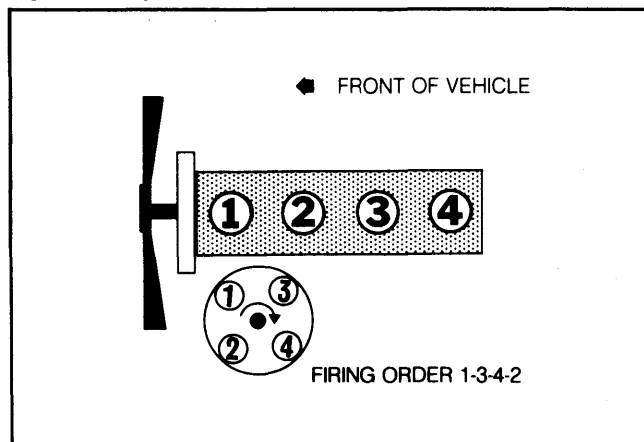

### IGNITION TIMING

Connect timing light and tachometer. Remove and plug vacuum hose at distributor (if equipped). With engine at normal operating temperature and at idle RPM, rotate distributor to set timing. Reinstall vacuum hose. Remove test equipment.

#### IGNITION TIMING (Degrees BTDC@RPM)

| Application        | Timing |
|--------------------|--------|
| Turbo Engine ..... | 12@900 |
| All Others .....   | 12@750 |

# 1982 Volvo 4 Tune-Up

## TUNE-UP (Cont.)

**Fig. 2: Timing Mark Location**

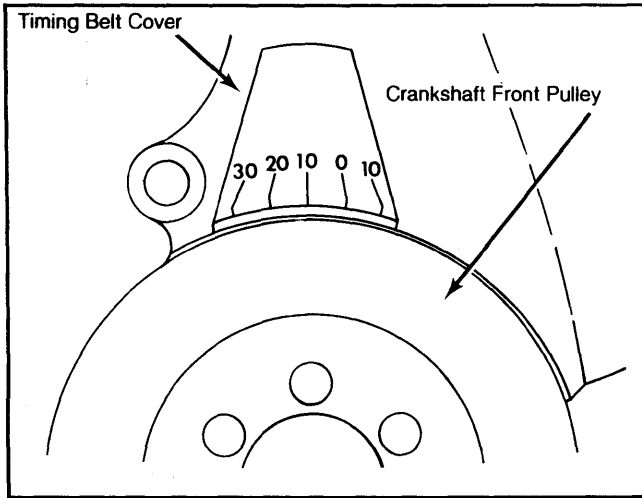

**Fig. 3: Idle Mixture Adjustment**

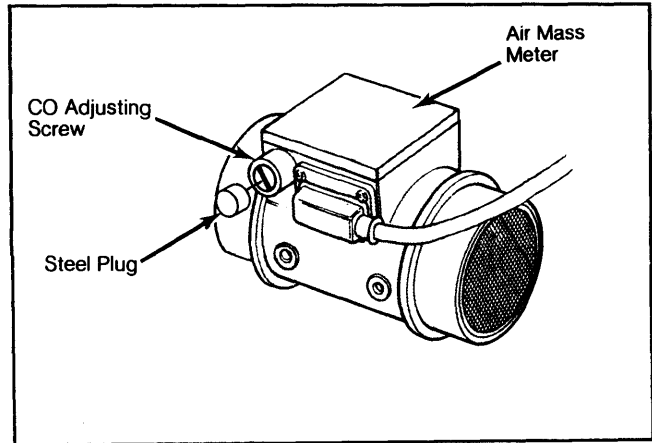

*LH-Jetronic models shown.*

### IDLE SPEED & MIXTURE

#### IDLE SPEED

All models are equipped with electronic idle speed control and no adjustments are possible.

#### IDLE MIXTURE

**NOTE:** Adjustment is not a normal tune-up procedure and should not be performed unless vehicle fails emission testing.

1) On CIS models, remove mixture control unit, separate control unit and drive out mixture plug (steel ball) with a punch. Reassemble control unit and reinstall.

2) On LH-Jetronic models, remove the aluminum/steel plug from air mass meter to gain access to mixture screw. On all models, disconnect oxygen sensor connector. Remove plug from exhaust pipe (in front of converter) and insert CO meter probe.

3) If CO reading is not within specifications, insert adjusting wrench (5015) or screwdriver (LH-Jetronic models only) into adjustment hole and adjust CO reading to specifications.

4) Reconnect oxygen sensor electrical connector and check CO reading. Repeat adjustment procedure if necessary. See Fig. 3. After each adjustment, remove adjusting wrench and cover adjustment hole. This will prevent a lean mixture while checking CO level.

5) After CO adjustment, remove test equipment. Insert exhaust pipe plug and seal mixture adjustment hole.

**Fig. 4: Idle Mixture Adjustment**

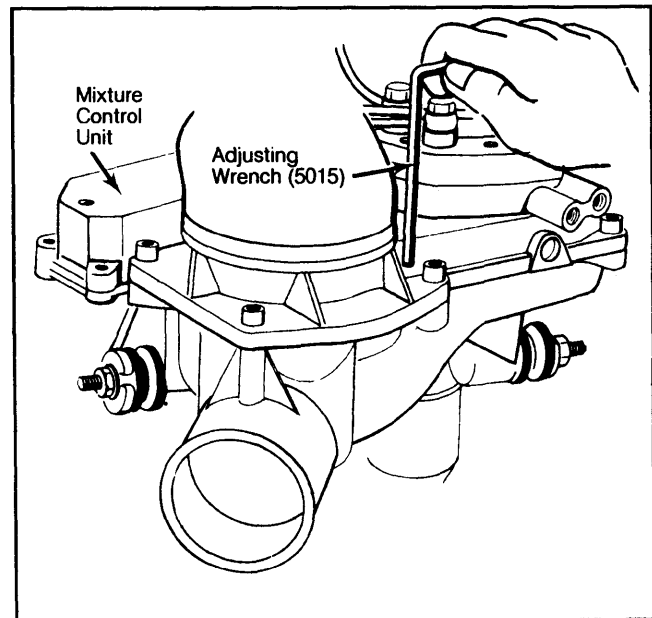

*CIS models shown.*

### FUEL PUMP

Check fuel pump with full battery charge and clean fuel filter.

#### FUEL PUMP PERFORMANCE

| Application | Pressure<br>psi (kg/cm <sup>2</sup> ) | Volume in 30 sec.<br>Pints (Liters) |
|-------------|---------------------------------------|-------------------------------------|
| Turbo       | 75-83 (5.2-5.8)                       | 2.1 (1.0)                           |
| All Others  | 64-76 (4.5-5.3)                       | 1.7 (0.8)                           |

#### IDLE SPEED & CO LEVEL

| Application      | Idle RPM | <sup>1</sup> CO% |
|------------------|----------|------------------|
| Non-Turbo        |          |                  |
| CIS Injection    | 750      | 0.7-1.3          |
| LH-Jetronic Inj. | 750      | 0.4-0.8          |
| Turbo            | 900      | 0.7-1.3          |

<sup>1</sup> — With oxygen sensor disconnected. Less than 1% with oxygen sensor connected.

### EXHAUST EMISSION SYSTEMS

See EXHAUST EMISSION SYSTEMS section.

# 1982 Volvo 4 Tune-Up

1-121

## GENERAL SERVICING

### IGNITION

#### DISTRIBUTOR

All models except Turbo are equipped with a Volvo Breakerless Ignition System, featuring computer controlled spark advance and a Hall Effect distributor. The Turbo is equipped with a Bosch Electronic Ignition System. For both systems, no adjustments are required.

### FUEL SYSTEMS

#### FUEL INJECTION

Some 4-door and 5-door DL models are equipped with Bosch LH-Jetronic fuel injection with oxygen sensor. All other models are equipped with Bosch Lambda CIS fuel injection with oxygen sensor.

### ELECTRICAL

#### BATTERY

##### BATTERY SPECIFICATIONS

| Application      | Amp. Hour Rating |
|------------------|------------------|
| All Models ..... | 55               |

#### STARTER

All models are equipped with Bosch overrunning clutch starters.

##### STARTER SPECIFICATIONS

| Application      | Volts | Amps  | Test RPM  |
|------------------|-------|-------|-----------|
| All Models ..... | 11.5  | 30-50 | 5500-7500 |

#### ALTERNATOR

All models are equipped with Bosch alternators with integral voltage regulators.

##### ALTERNATOR SPECIFICATIONS

| Application      | Rated Amp. Output |
|------------------|-------------------|
| All Models ..... | 70                |

#### ALTERNATOR REGULATOR

All models are equipped with Bosch alternator regulators.

##### REGULATOR OPERATING VOLTAGE@68°F (20°C)

| Application      | Voltage   |
|------------------|-----------|
| All Models ..... | 13.0-15.0 |

### SERVICE SPECIFICATIONS

#### BELT ADJUSTMENT

| Application     | <sup>1</sup> Deflection In. (mm) |
|-----------------|----------------------------------|
| All Belts ..... | 2-4 (5-10)                       |

<sup>1</sup> — Deflection is measured with moderate thumb pressure applied at midpoint of longest belt run.

#### REPLACEMENT INTERVALS

| Component              | Miles  |
|------------------------|--------|
| Oil Filter             |        |
| Turbo .....            | 3750   |
| All Other Models ..... | 7500   |
| Air Filter .....       | 30,000 |
| Fuel Filter .....      | 15,000 |
| Fuel Tank Filter ..... | 60,000 |
| Spark Plugs .....      | 30,000 |
| Oxygen Sensor .....    | 30,000 |
| PCV Valve .....        | 30,000 |

#### FLUID CAPACITIES

| Application                            | Quantity           |
|--|--------------------|
| Crankcase (Including Filter)           |                    |
| Exc. Turbo .....                       | 4.0 qts. (3.8L)    |
| Turbo .....                            | 4.7 qts. (4.5L)    |
| Cooling System (Includes Heater) ..... | 10.0 qts. (9.4L)   |
| Man. Trans. (ATF Type F)               |                    |
| With Overdrive .....                   | 4.8 pts. (2.3L)    |
| Without Overdrive .....                | 1.6 pts. (0.8L)    |
| Auto. Trans. (ATF Type F) .....        | 14.6 pts. (6.9L)   |
| Rear Axle (SAE 90) .....               | 3.4 pts. (1.6L)    |
| Fuel Tank .....                        | 15.8 gals. (60.0L) |