

1982 Mazda Rotary Tune-Up

TUNE-UP

RX7

ENGINE IDENTIFICATION

Engine type code is stamped on rear rotor housing, to the rear of oil filter. Engine serial number is stamped on front rotor housing behind distributor.

ENGINE COMPRESSION

Start and run engine until it reaches normal operating temperature. Disconnect all spark plug wires and remove 1 spark plug from each chamber. Check compression of each chamber with engine at cranking speed (250 RPM).

COMPRESSION SPECIFICATIONS

Min. Compression Pressure	86 psi (6.0 kg/cm ²)
Max. Variation	21 psi (1.5 kg/cm ²)

SPARK PLUGS

SPARK PLUG TYPE

Application	Nippondenso No.	NGK No.
All Models	W25EDR14	BR8EQ14

SPARK PLUG SPECIFICATIONS

Application	Gap In. (mm)	Torque Ft. Lbs. (N.m)
All Models	.055 (1.4)	11 (15)

HIGH TENSION WIRE RESISTANCE

Carefully remove high tension wires from spark plugs and distributor cap. Using an ohmmeter, measure resistance of wires while gently twisting wires. If resistance is not to specifications, or fluctuates from infinity to any value, replace high tension wire(s).

WIRE RESISTANCE

Application	Ohms
All Models	3300-7000 per foot

DISTRIBUTOR

All models are equipped with Mitsubishi electronic ignition with 2 pick-up coils. Air gap is non-adjustable.

Fig. 1: Firing Order and Distributor Rotation

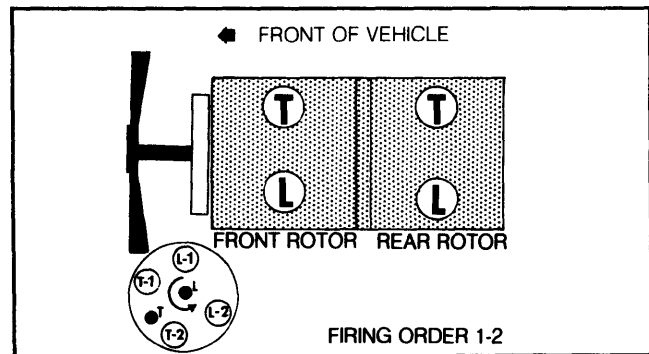

IGNITION TIMING

NOTE: On vehicles equipped with automatic transmission, place selector lever in "D" position and block the wheels.

1) Warm engine to normal operating temperature. Connect a tachometer, then connect timing light to leading (lower) spark plug of front rotor. Start engine and run at idle speed.

2) Check ignition timing and rotate distributor to correct if necessary. Tighten distributor lock nut and recheck timing.

Fig. 2: Connecting Timing Light

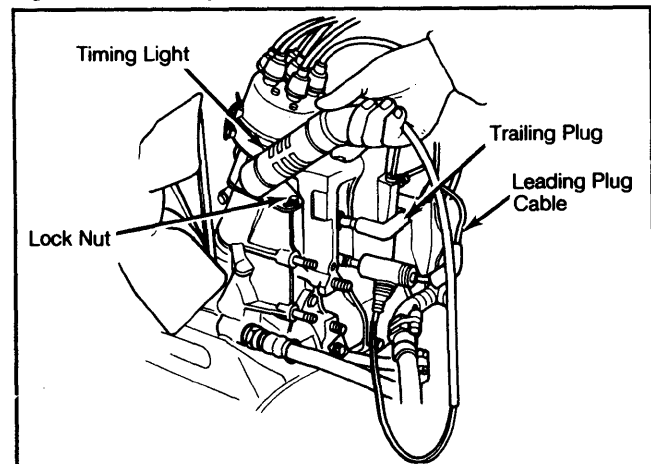

Check leading plug timing first.

Fig. 3: Ignition Timing Mark Location

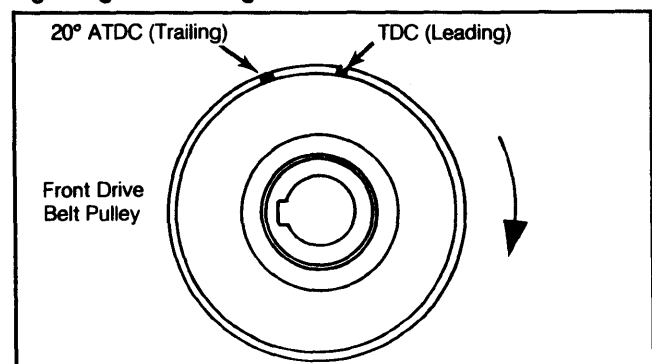

TUNE-UP (Cont.)

3) Connect timing light to trailing (upper) plug of front rotor. Start engine and check timing. If not correct, loosen vacuum unit attaching screws and move vacuum unit in or out to adjust trailing timing. Remove test equipment.

IGNITION TIMING

Application	Timing
Leading	TDC
Trailing	20°ATDC

IDLE SPEED & MIXTURE

NOTE: Mixture adjustment is NOT part of normal tune-up procedure and should not be performed unless carburetor is overhauled or vehicle fails emissions testing.

1) Switch off all accessories. Remove fuel filler cap. Disconnect and plug idle compensator tube at air cleaner. Connect tachometer to engine. Ensure parking brake is engaged and wheels are blocked.

2) On manual transmission models, make sure dashpot rod does not keep throttle lever from returning to stop. On air conditioned models, make sure throttle opener does not keep throttle lever from returning to stop.

3) Warm engine to normal operating temperature. Place automatic transmission in "D". Check idle speed. Adjust curb idle speed to specification by turning throttle adjusting screw.

NOTE: Idle mixture adjustment requires removal of carburetor to remove limiter cap.

4) Using a hacksaw, cut through limiter cap and mixture screw 0.4" (10 mm) from cap end. Remove mixture screw and install new mixture screw.

5) To install new mixture screw, tighten screw lightly and ensure it is fully seated. Back screw out 3 turns for preliminary adjustment. Reinstall carburetor with new gaskets and warm engine to normal operating temperature.

6) To adjust idle mixture, set idle speed to idle set specification by turning throttle set screw (automatic transmission in "N"). Set idle speed to highest RPM obtainable by turning mixture screw. Reset idle speed to idle set specification by turning throttle screw. See Fig. 4.

7) Turn mixture screw until lean drop specification is obtained (automatic transmission in "N"). On automatic transmission, shift transmission to "D" and set idle speed to curb idle specification by turning throttle screw.

IDLE SPEED & MIXTURE

Application	Curb Idle RPM	Idle Set RPM	Lean Drop RPM
Man. Trans.	750	770	750
Auto. Trans.	¹ 750	² 870	² 840

¹ — Transmission in "D".

² — Transmission in "N".

Fig. 4: Carburetor Adjusting Screw Locations

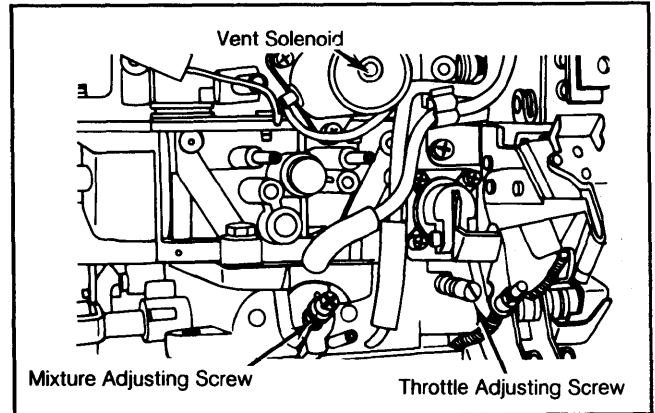

COLD (FAST) IDLE RPM

NOTE: Carburetor must be removed to check and/or adjust fast idle.

Adjust fast idle by setting angle of primary throttle valve with choke valve fully closed. Clearance between primary throttle valve and throttle bore should be .032-.040" (0.8-1.0 mm). If not to specification, bend fast idle rod until correct clearance is obtained.

FUEL PUMP

FUEL PUMP PERFORMANCE

Application	Pressure psi (kg/cm ²)	Volume in 30 Sec. Pints (Liters)
All Models	4.2 (.3)	1.3 (1.2)

EXHAUST EMISSION SYSTEMS

See EXHAUST EMISSION SYSTEMS section.

GENERAL SERVICING

IGNITION

DISTRIBUTOR

All models are equipped with Mitsubishi electronic ignition systems.

IGNITION COIL

RESISTANCE Ohms@68°F (20°C)

Application	Primary	Secondary
All Models81-.99

1982 Mazda Rotary Tune-Up

GENERAL SERVICING (Cont.)

FUEL SYSTEMS

CARBURETOR

All models use a Hitachi 4-Bbl. carburetor.

ELECTRICAL

BATTERY

BATTERY SPECIFICATIONS

Application	Amp. Hr. Capacity
G60-5 & Y60-5	45
NS70S	55

STARTER

All models are equipped with a Mitsubishi starter using an overrunning clutch.

STARTER SPECIFICATIONS

Application	Volts	Amps	Test RPM
Man. Trans.	11.5	50	5600
Auto. Trans.	11.5	100	3500

ALTERNATOR

All models are equipped with a Mitsubishi alternator.

ALTERNATOR SPECIFICATIONS

Application	Rated Amp. Output
All Models	50

ALTERNATOR REGULATOR

All models are equipped with a Mitsubishi voltage regulator.

REGULATOR OPERATING VOLTAGE@68°F (20°C)

Application	Voltage
All Models	13.5

SERVICE SPECIFICATIONS

BELT ADJUSTMENT

Application	¹ Deflection In. (mm)
Alternator Belt5-.7 (13-17)
Air Pump Belt43-.51 (11-13)
A/C Belt39-.47 (10-12)

¹ — Deflection is with 22 lbs. (10 kg) pressure applied midway on longest belt run.

REPLACEMENT INTERVALS

Component	Miles
Engine Oil	7500
Oil Filter	15,000
Air Filter	30,000
Spark Plugs	30,000

FLUID CAPACITIES

Application	Quantity
Crankcase (Includes Filter)	5.5 qts. (5.2L)
Cooling System (Includes Heater)	10.0 qts. (9.5L)
Man. Trans. (SAE 90)	2.1 qts. (1.9L)
Auto Trans. (ATF Type F)	6.6 qts. (6.2L)
Rear Axle (SAE 90)	2.6 pts. (1.2L)
Fuel Tank	16.4 gals. (62.1L)