

1982 Mazda 4 Tune-Up

TUNE-UP

B2000 Pickup, GLC, 626

ENGINE IDENTIFICATION

Engine serial number and model code are stamped on right front upper wall of cylinder block.

ENGINE COMPRESSION

Check compression pressure with engine at normal operating temperature, spark plugs removed, throttle valve wide open and engine at cranking speed. Crank engine until maximum pressure is reached at each cylinder.

COMPRESSION SPECIFICATIONS

Normal Compression Pressure	171 psi (12 kg/cm ²)
Min. Compression Pressure	128 psi (9 kg/cm ²)
Max. Variation	28 psi (2 kg/cm ²)

VALVE CLEARANCE

Adjust valves with engine at normal operating temperature.

VALVE CLEARANCE SPECIFICATIONS

Application	Clearance In. (mm)
Intake	
GLC010 (.25)
626 & B2000012 (.30)
Exhaust012 (.30)

VALVE ARRANGEMENT

Right Side — All Exhaust
Left Side — All Intake

SPARK PLUGS

SPARK PLUG TYPE

Application	NGK No.
All Models BPR-5ES or BPR-6ES

SPARK PLUG SPECIFICATIONS

Application	Gap In. (mm)	Torque Ft. Lbs. (N.m)
All Models031 (0.8) 13 (18)

HIGH TENSION WIRE RESISTANCE

Carefully remove high tension wires from spark plugs and distributor cap. Using an ohmmeter, check resistance of wires while gently twisting wire. If resistance is not to specification, or fluctuates from infinity to any value, replace wire.

WIRE RESISTANCE

Application	Ohms
All Models 3300-7000 per ft.

Fig. 1: Firing Order and Distributor Rotation (GLC Exc. Wagon)

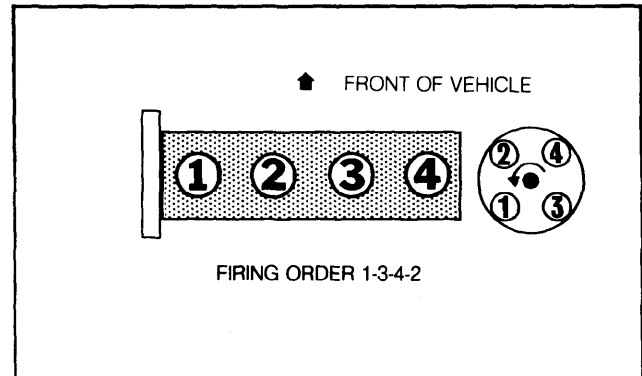
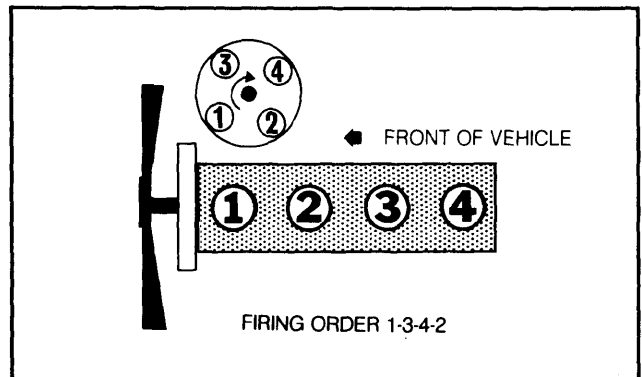

Fig. 2: Firing Order and Distributor Rotation (GLC Wagon, 626 & B2000)



DISTRIBUTOR

All models are equipped with a Mitsubishi breakerless electronic ignition system and no adjustments are needed.

IGNITION TIMING

Timing is checked with engine at normal operating temperature, idle speed set to specification and Man. Trans. in neutral or Auto. Trans. in "D". Connect a timing light and tachometer to engine. Start engine and rotate distributor until specified mark on crankshaft pulley aligns with indicator pin.

IGNITION TIMING (Degrees BTDC@RPM)

Application	Man. Trans.	Auto Trans.
GLC	8@850	8@750
GLC Wagon	8@800	8@750
626	5@650	5@650
B2000	8@650

¹ — Auto. Trans. in "D".

TUNE-UP (Cont.)

Fig. 3: Ignition Timing Mark Location

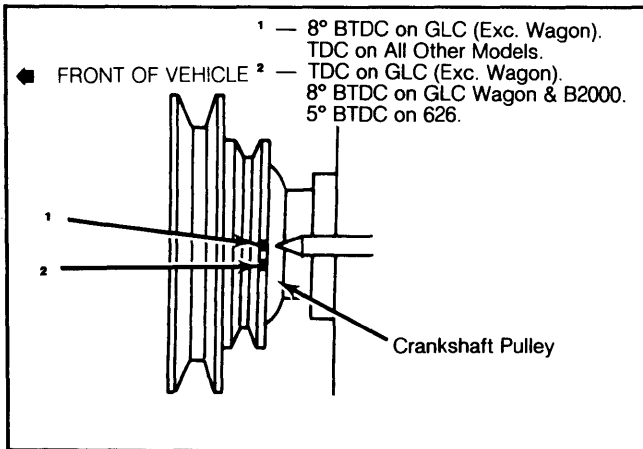

IDLE SPEED AND MIXTURE

IDLE SPEED

1) Switch off all accessories. Set parking brake and block drive wheels. Connect tachometer to engine.

2) Warm engine to normal operating temperature. Place automatic transmission in "D". Check idle speed. Adjust curb idle to specification by turning throttle adjusting screw.

NOTE: On GLC models (Except Wagon), do not adjust curb idle until electric fan motor stops running.

IDLE SPEED (RPM)

Application	Man. Trans.	1 Auto. Trans.
GLC	850	750
GLC Wagon	800	750
626	650	650
B2000	650

1 — Auto. Trans. in "D".

Fig. 4: Carburetor Adjustment Screw Location

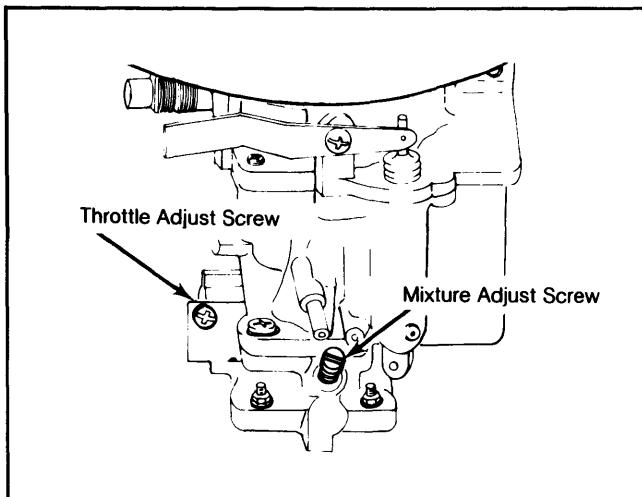

IDLE MIXTURE

NOTE: Idle mixture adjustment is generally not required. Idle mixture adjustment should be performed during carburetor overhaul. All models require removal and disassembly of carburetor to remove idle mixture screw limiter shell and blind cap.

626 Models

1) Start and run engine until it reaches normal operating temperature. Disconnect reed valve air hose and plug reed valve port. Connect an exhaust gas analyzer to the vehicle and measure CO concentration.

2) Adjust CO concentration to specifications by turning mixture adjusting screw. Reconnect air hose and check for increase in idle speed. If idle speed changes when air hose is installed, adjustment procedure must be repeated.

IDLE MIXTURE ADJUSTMENT

Application	CO %
626	2.0

All Other Models

1) Remove carburetor from engine. Separate carburetor main body and throttle body. Using a hacksaw, cut through limiter shell (from cap end) .27" (7 mm) on GLC models (except Wagon) or .47" (12 mm) on all other models. See Fig. 5. Remove and discard limiter shell, mixture spring and mixture screw.

2) Install new limiter shell with flat portion facing up. To install new mixture screw, tighten screw lightly and ensure it is fully seated. Back screw out 3 turns on B2000 models and 4 turns on all other models for preliminary adjustment.

3) Reinstall carburetor with new gaskets and warm engine to normal operating temperature. Connect exhaust gas analyzer. Switch off all accessories.

4) On Federal B2000 models, disconnect air cleaner-to-reed valve hose at reed valve port. On Calif. B2000 models, disconnect air by-pass valve-to-check valve hose at check valve and plug check valve port. On all other models, disconnect air control valve-to-check valve hoses at check valves and plug check valve ports.

Fig. 5: Idle Mixture Limiter Shell

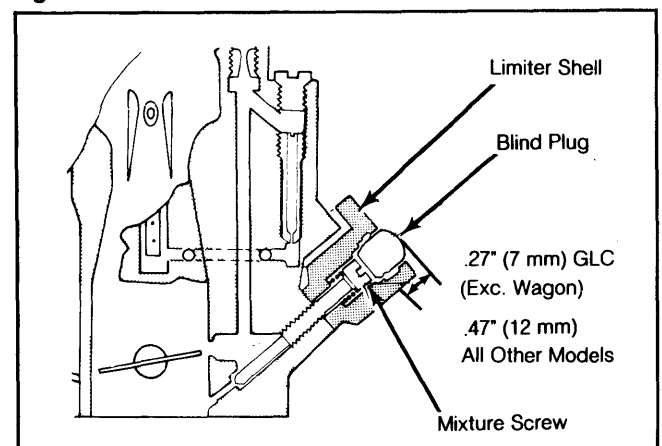

5) On all models, adjust idle speed to idle set specification using throttle adjusting screw. See Mixture

1982 Mazda 4 Tune-Up

TUNE-UP (Cont.)

Adjustment specifications. Using mixture screw, set idle speed to highest obtainable RPM.

6) Using throttle screw, set idle speed to idle set specification. Turn mixture screw clockwise until lean drop specification is obtained. See *Mixture Adjustment specifications.*

7) Check CO concentration. If less than 1%, turn mixture screw counterclockwise 1/2 turn (1/4 turn on B2000 models). Reconnect air hose and check curb idle speed. After adjusting idle mixture, install blind plug in limiter shell.

IDLE MIXTURE ADJUSTMENT

Application	Idle Set RPM	Lean Drop RPM
GLC		
Man. Trans	880	850
Auto Trans. ¹	1030	1000
GLC Wagon		
Man. Trans	830	800
Auto Trans. ¹	1030	1000
B2000		
Federal	670	650
Calif.	620	600

¹ — Auto. Trans. in "N".

COLD (FAST) IDLE RPM

1) Adjust fast idle by setting angle of primary throttle valve with choke fully closed. Position fast idle cam on first step (second step on GLC Wagon and 626 models.)

2) Clearance between primary throttle valve and throttle bore should be .026" (.67 mm) on GLC models; .031" (.78 mm) on GLC Wagon models; .018-.030" (.45-.75 mm) on 626 models; and .05-.06" (1.3-1.5 mm) on B2000 models. Adjust angle to specifications by turning adjusting screw.

FUEL PUMP

FUEL PUMP PERFORMANCE

Application	Pressure psi (kg/cm ²)	Volume in 30 Sec. Pints (Liters)
GLC	3.3 (.24)	.7 (.3)
626 & B2000	3.2 (.23)	.8 (.4)

EXHAUST EMISSION SYSTEMS

See EXHAUST EMISSION SYSTEMS section.

GENERAL SERVICING

IGNITION

DISTRIBUTOR

All models are equipped with a Mitsubishi breakerless electronic ignition system.

IGNITION COIL

RESISTANCE Ohms@68°F (20°C)

Application	Primary	Secondary
GLC, GLC Wagon & 626	1.15
B200090	7000

FUEL SYSTEMS

All GLC models use Hitachi 2-bbl. carburetors. All other models use Nikki 2-bbl. carburetors.

ELECTRICAL

BATTERY

BATTERY SPECIFICATIONS

Application	Amp Hr. Rating
GLC	
Federal	45
Calif.	33
GLC Wagon	60
626 & B2000	¹ 45

¹ — 70 Amp. Battery also available on B2000.

STARTER

All models are equipped with a Mitsubishi starter that uses an overrunning clutch.

STARTER SPECIFICATIONS

Application	Volts	Amps	Test RPM
626 Auto Trans.	11.5	60	6600
All Other Models	11.5	53	6800

ALTERNATOR

All models use Mitsubishi alternators.

ALTERNATOR SPECIFICATIONS

Application	Rated Amp. Output
B2000	50
GLC	30
626	42

ALTERNATOR REGULATOR

All models are equipped with a Mitsubishi adjustable alternator regulator.

REGULATOR OPERATING VOLTAGE@68°F (20°C)

Application	Voltage
All Models	13.0-15.0

1982 Mazda 4 Tune-Up

GENERAL SERVICING (Cont.)

SERVICE SPECIFICATIONS

BELT ADJUSTMENT

Application	¹ Deflection In. (mm)
Alternator Belt	² .3-.4 (8-10)
Air Conditioner Belt6-.7 (15-18)
Air Pump Belt	
GLC Wagon	³ .3-.4 (8-10)
626 & B20004-.6 (10-15)

¹ — Deflection is with 22 lbs. (10 kg) pressure applied midway on longest belt run.

² — GLC (except Wagon) is .47-.50" (12-13 mm).

³ — GLC (except Wagon) is .63-.70" (16-18 mm); with A/C, .43-.50" (11-13 mm).

REPLACEMENT INTERVALS

Component	Miles
Oil Filter	7500
Air Filter	30,000
Fuel Filter (B2000)	15,000
Spark Plugs	30,000

FLUID CAPACITIES

Application	Quantity
Crankcase (Includes Filter)	
GLC	3.9 qts. (3.7L)
B2000	4.1 qts. (3.9L)
626	3.8 qts. (3.6L)
Cooling System (Includes Heater)	
GLC	5.8 qts. (5.5L)
626	7.9 qts. (7.5L)
B2000	7.6 qts. (7.2L)
Manual Transaxle (ATF type "F")	3.4 qts. (3.2L)
Manual Transmission (SAE 80W-90)	
4-Speed	
GLC Wagon	1.4 qts. (1.3L)
B2000	1.5 qts. (1.4L)
5-Speed	1.8 qts. (1.7L)
Automatic Transaxle (ATF Type "F")	6.0 qts. (5.7L)
Automatic Transmission (ATF Type "F")	
GLC Wagon	6.0 qts. (5.7L)
626	6.6 qts. (6.2L)
Rear Axle (SAE 80W-90)	
GLC Wagon	1.6 pts. (.8L)
626	2.6 pts. (1.2L)
B2000	2.8 pts. (1.3L)
Fuel Tank	
GLC	11.1 gals. (42.0L)
GLC Wagon	11.9 gals. (45.0L)
626	14.5 gals. (54.9L)
B2000	
Standard Bed	14.8 gals. (56.0L)
Long Bed	17.4 gals. (65.9L)