

# 1982 LUV 4 Tune-Up

## TUNE-UP

### Pickup

### ENGINE IDENTIFICATION

Engine serial number is stamped on pad between distributor and cylinder head.

#### ENGINE CODE

| Application   | Code  |
|---------------|-------|
| 1817 cc ..... | G1802 |

### COMPRESSION PRESSURE

Test compression with engine at normal operating temperature, spark plugs removed, throttle valve wide open and engine at cranking speed (300 RPM.)

#### COMPRESSION SPECIFICATIONS

|  |                                  |
|--|----------------------------------|
| Compression Ratio .....                | 8.5:1                            |
| Compression Pressure .....             | 170 psi (12 kg/cm <sup>2</sup> ) |
| Max. Variation Between Cylinders ..... | 15%                              |

### VALVE CLEARANCE

**NOTE:** Before adjusting valve clearance, check torque of cylinder head and camshaft bolts. Valves should be adjusted every 15,000 miles with engine cold.

1) Measure valve clearance between rocker arm and valve stem. Position No. 1 piston on TDC of compression stroke. Adjust intake valve on cylinder No. 1 and 2, and exhaust valves on cylinder No. 1 and 3.

2) Turn crankshaft 1 full revolution until No. 4 piston is at TDC of compression stroke. Adjust intake valves on cylinder No. 3 and 4, and exhaust valves on cylinder No. 2 and 4.

#### VALVE CLEARANCE SPECIFICATIONS

| Application                   | Intake<br>In. (mm) | Exhaust<br>In. (mm) |
|-------------------------------|--------------------|---------------------|
| All Models <sup>1</sup> ..... | .006 (.15)         | .010 (.25)          |

<sup>1</sup> — Set valves with engine cold.

### VALVE ARRANGEMENT

Right Side — All Intake  
Left Side — All Exhaust

### SPARK PLUGS

#### SPARK PLUG TYPE

| Application      | NGK No.  |
|------------------|----------|
| All Models ..... | BPR6ES11 |

#### SPARK PLUG SPECIFICATIONS

| Application      | Gap<br>In. (mm) | Torque<br>Ft. Lbs. (N.m) |
|------------------|-----------------|--------------------------|
| All Models ..... | .040 (1.05)     | 18-25 (24-33)            |

### HIGH TENSION WIRE RESISTANCE

Carefully remove high tension wires from spark plugs and from distributor cap. Using an ohmmeter check resistance of wire while gently twisting wire. If resistance is not to specification, or fluctuates from infinity to any value, replace wire.

#### WIRE RESISTANCE

| Application      | Ohms          |
|------------------|---------------|
| All Models ..... | 31,500-73,500 |

### DISTRIBUTOR

All models equipped with Nippondenso electronic ignition system.

#### DISTRIBUTOR SPECIFICATIONS

|               |                       |
|---------------|-----------------------|
| Air Gap ..... | .008-.016" (.2-.4 mm) |
|---------------|-----------------------|

Fig. 1: Firing Order and Distributor Rotation

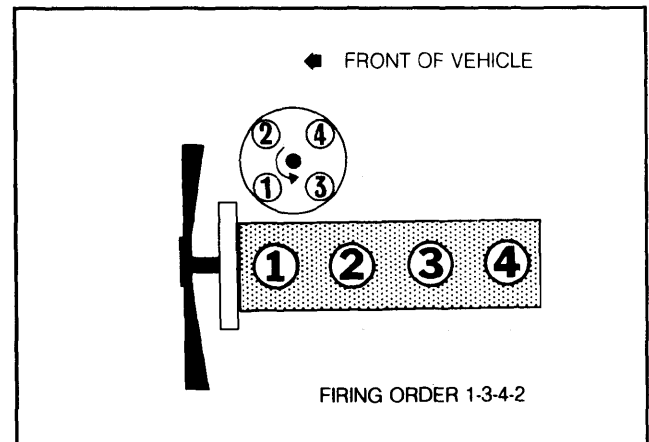

### IGNITION TIMING

1) Ensure engine is warmed up to normal operating temperature, and that air gap in distributor is correct.

2) Connect timing light to either No. 1 or No. 4 cylinder. Remove distributor vacuum advance line and plug.

3) Loosen distributor clamping bolts and turn distributor until timing is within specifications.

# 1982 LUV 4 Tune-Up

## TUNE-UP (Cont.)

**Fig. 2: Ignition Timing Mark Location**

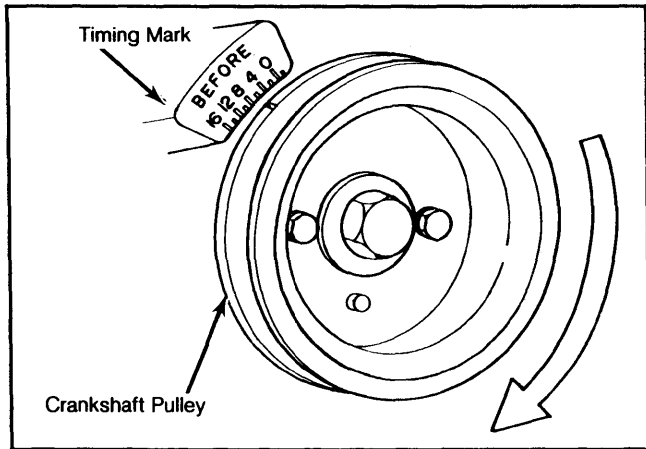

### IGNITION TIMING (Degrees BTDC@RPM)

| Application                            | Timing |
|--|--------|
| Federal Man. Trans. <sup>1</sup> ..... | 6@800  |
| All Other Models <sup>1</sup> .....    | 6@900  |

<sup>1</sup> — Disconnect and plug distributor vacuum hose.

### IDLE SPEED & MIXTURE

**NOTE:** Mixture adjustment is NOT a part of normal tune-up procedure and should not be performed unless carburetor is replaced or vehicle fails emissions testing.

1) Remove carburetor assembly. Remove plug from idel mixture screw by using a screwdriver which will insert into the slit on carburetor lower flange. See Fig. 3. Reinstall carburetor assembly.

**Fig. 3: Removing Idle Mixture Screw Plug.**

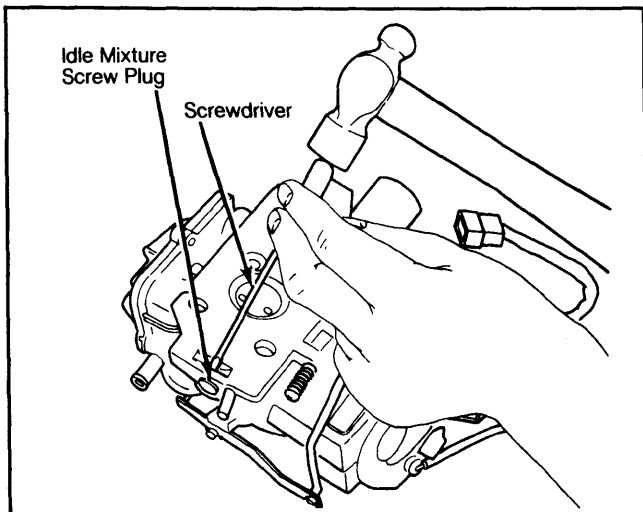

Carburetor must be removed and turned over to access plug

2) Check valve clearance and ignition timing. Choke should be open, air conditioning off. Disconnect and plug distributor vacuum line, canister purge line and EGR vacuum line. Close rubber idle compensator vacuum hose by bending.

3) Turn idle mixture adjusting screw fully in, then back out 2 turns (Federal) or 1 turn (Calif.). Set throttle adjusting screw to obtain specified mixture RPM.

4) Adjust idle mixture screw to obtain maximum RPM. Reset throttle adjusting screw to achieve specified mixture RPM. Turn idle mixture screw clockwise until speed drops to specified curb idle.

5) If equipped with air conditioner, turn on to maximum cooling and high blower. Open throttle slightly to allow solenoid to extend. Close throttle. Adjust solenoid screw to give 900 RPM idle. Replace tamper-proof plug.

### IDLE SPEED & MIXTURE

| Application       | Idle RPM | Mixture RPM |
|-------------------|----------|-------------|
| Federal           |          |             |
| Man. Trans. ....  | 800      | 850         |
| Auto. Trans. .... | 900      | 950         |
| Calif. ....       | 900      | 950         |

### COLD (FAST) IDLE

1) Automatic choke fast idle is adjusted by opening angle of throttle valve on carburetor, rather than by engine speed. Adjust valve opening at 1st step of fast idle cam by using thottle adjusting screw. Adjust to 16° manual transmission or 18° on automatic transmission.

2) Disconnect and plug distributor, hot idle compensator and EGR valve vacuum hoses after engine warm-up. If fast idle speed is not to specifications repeat step 1).

### FAST IDLE

| Application      | RPM  |
|------------------|------|
| All Models ..... | 3200 |

### AUTOMATIC CHOKE

Automatic choke is set from factory and is non-adjustable.

### FUEL PUMP

#### FUEL PUMP PERFORMANCE

| Application      | Pressure psi (kg/cm <sup>2</sup> ) |
|------------------|------------------------------------|
| All Models ..... | 3.6 (.25)                          |

### EXHAUST EMISSION SYSTEMS

See EXHAUST EMISSION SYSTEMS section.

# 1982 LUV 4 Tune-Up

1-63

## GENERAL SERVICING

### IGNITION

#### DISTRIBUTOR

All Models are equipped with a Nippondenso electronic distributor.

#### IGNITION COIL

##### RESISTANCE Ohms@68°F (20°C)

| Application | Primary   | Secondary     |
|-------------|-----------|---------------|
| All Models  | .083-1.02 | 12,150-14,850 |

### FUEL SYSTEMS

#### CARBURETORS

All models use Hitachi 2 Bbl. carburetors.

##### HITACHI CARBURETORS

| Application  | Model No.  |
|--------------|------------|
| Federal      |            |
| Man. Trans.  | DCH340-211 |
| 4-WD         | DCH340-212 |
| Auto. Trans. | DCH340-211 |
| Calif.       |            |
| Man. Trans.  | DCH340-213 |
| 4-WD         | DCH340-213 |
| Auto Trans.  | DCH340-214 |

### ELECTRICAL

#### BATTERY

##### BATTERY SPECIFICATIONS

| Application | Amp. Hr. Rating |
|-------------|-----------------|
| All Models  | 50              |

#### STARTER

All models use Hitachi starters.

##### STARTER SPECIFICATIONS

| Application | Volts | Amps | Test RPM |
|-------------|-------|------|----------|
| All Models  | 12    | 70   | 6000     |

#### ALTERNATOR

All models use Hitachi alternators.

##### ALTERNATOR SPECIFICATIONS

| Application | Rated Amp. Output |
|-------------|-------------------|
| All Models  | 40 or 50          |

#### ALTERNATOR REGULATOR

All models use Hitachi alternator regulator.

##### REGULATOR OPERATING VOLTAGE

| Application | Voltage   |
|-------------|-----------|
| All Models  | 13.8-14.8 |

### SERVICE SPECIFICATIONS

##### BELT ADJUSTMENT

| Application     | Deflection In. (mm) |
|-----------------|---------------------|
| All Drive Belts | .4 (10)             |

<sup>1</sup> — With moderate hand pressure applied midway between pulleys belt run.

##### REPLACEMENT INTERVALS

| Component   | Miles               |
|-------------|---------------------|
| Oil Filter  | <sup>1</sup> 15,000 |
| Air Filter  | 30,000              |
| Fuel Filter | 30,000              |
| Spark Plugs | 30,000              |

<sup>1</sup> — Replace at 7500 miles and then every 15,000 miles.

##### FLUID CAPACITIES

| Application                   | Quantity           |
|-------------------------------|--------------------|
| Crankcase (Includes Filter)   | 4.2 qts. (4.0L)    |
| Cooling System                |                    |
| Auto. Trans.                  | 6.4 qts. (6.0L)    |
| Man. Trans.                   | 6.8 qts. (6.5L)    |
| Man. Trans. (SAE 30)          |                    |
| 2-WD                          | 2.7 pts. (1.3L)    |
| 4-WD (Includes Trans. Case)   | 5.3 pts. (2.5L)    |
| Auto. Trans. (Dexron II)      |                    |
| Refill                        | 3.5 qts. (3.3L)    |
| Overhaul (Includes Converter) | 7.0 qts. (6.6L)    |
| Front Axle (SAE 90)           | 1.7 pts. (.8L)     |
| Rear Axle (SAE 90)            | 2.7 pts. (1.3L)    |
| Fuel Tank                     |                    |
| Short Wheelbase               | 13.2 gals. (50.0L) |
| Long Wheelbase                | 18.5 gals. (70.0L) |