

1982 Courier 4 Tune-Up

TUNE-UP

Pickup

ENGINE IDENTIFICATION

The engine identification number is stamped on right side of engine block below distributor and on model identification plate attached to body at right rear corner of engine compartment. Engine model code is the 8th digit of identification number.

ENGINE CODE

Application	Code
2000 cc	1
2300 cc	2

ENGINE COMPRESSION

Check compression pressure with engine at normal operating temperature. Remove spark plugs. Throttle valve should be wide open and engine at cranking speed. Crank engine at least 5 strokes and record highest reading. Repeat for each cylinder. Compression pressure is within specifications if lowest reading cylinder is more than 75% of highest.

COMPRESSION SPECIFICATIONS

Compression Ratio	8.6:1
Max. Variation Between Cylinders	25%

VALVE CLEARANCE

NOTE: Valve adjustment is required on 2.0L engines only. The 2.3L engine is equipped with hydraulic valve lifters which require no adjustment during engine tune-up.

1) Run engine until normal operating temperature is reached. Turn off engine and remove valve rocker arm cover. Tighten cylinder head bolts to 70 ft. lbs. (95 N.m). Rotate crankshaft so that No. 1 piston is at TDC. Check clearance with a feeler gauge.

2) If clearance is incorrect, loosen adjusting screw lock nut and adjust clearance by turning adjusting screw with feeler gauge inserted. Adjust valves in firing order sequence.

VALVE CLEARANCE SPECIFICATIONS

Application	Clearance In. (mm)
Intake & Exhaust (Hot)012 (.3)

VALVE ARRANGEMENT

2000 cc
 Right Side — All Exhaust
 Left Side — All Intake
 2300 cc
 E-I-E-I-E-I-E-I (Front to rear)

SPARK PLUGS

SPARK PLUG TYPE

Application	NGK No.
2000 cc	BPR5ES
2300 cc	BPR5EFS

SPARK PLUG SPECIFICATIONS

Application	Gap In. (mm)	Torque Ft. Lbs. (N.m)
2000 cc031 (.8)	11-15 (15-20)
2300 cc034 (.9)	5-10 (7-14)

HIGH TENSION WIRE RESISTANCE

Carefully remove ends of wire from spark plug and distributor. Using an ohmmeter, check resistance of wire while gently twisting wire. If resistance is incorrect, or fluctuates from infinity to any value, replace wire.

WIRE RESISTANCE

Application	Ohms
All Models	570

DISTRIBUTOR

All the models are equipped with Mitsubishi breakerless, electronic ignition system.

AIR GAP

Application	Gap In. (mm)
All Models016 (.4)

Fig. 1: Firing Order and Distributor Rotation

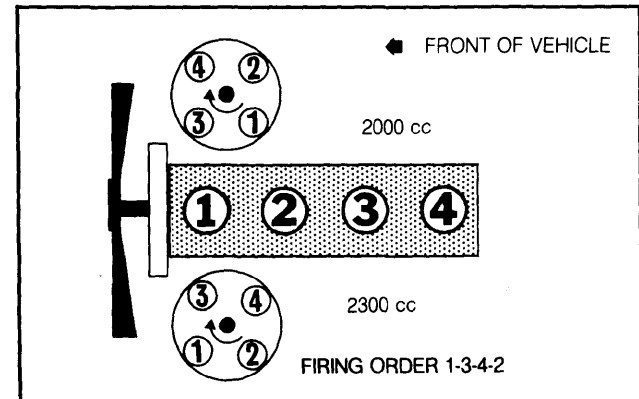

IGNITION TIMING

Check or adjust ignition timing with engine at normal operating temperature and idle speed. Distributor vacuum advance line should be disconnected and plugged on 2.3L engines.

TUNE-UP (Cont.)

IGNITION TIMING (Degrees BTDC@RPM)

Application	Timing
2000 cc	8@650
2300 cc	6@850

Fig. 2: Ignition Timing Mark Locations

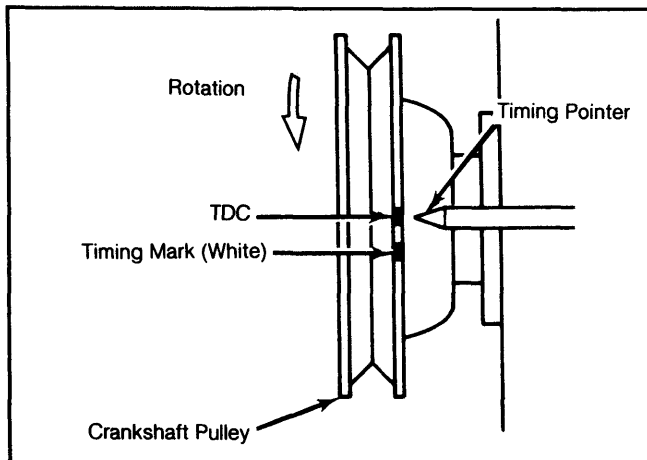

Timing mark is 8° BTDC on 2000 cc engines and at 6° BTDC on 2300 cc engines.

IDLE SPEED & MIXTURE

NOTE: Mixture adjustment is NOT a part of normal tune-up procedures and should not be performed unless carburetor is replaced or vehicle fails emissions testing.

1) Check and adjust ignition timing and carburetor float level. With transmission in Neutral and engine at normal operating temperature, check that choke is fully open.

2) Connect a tachometer and run engine at 2000 RPM for 3 minutes. Disconnect hose between canister and air cleaner. Adjust idle speed as necessary, by turning throttle adjusting screw. Reconnect hose.

3) On 2000 cc engines with low altitude emissions, remove mixture adjusting screw and shell. To remove, pull outward on shell while turning counterclockwise, or cut shell at point shown in Fig. 3. Connect exhaust gas analyzer to vehicle.

Fig. 3: Mixture Adjusting Screw and Shell Removal

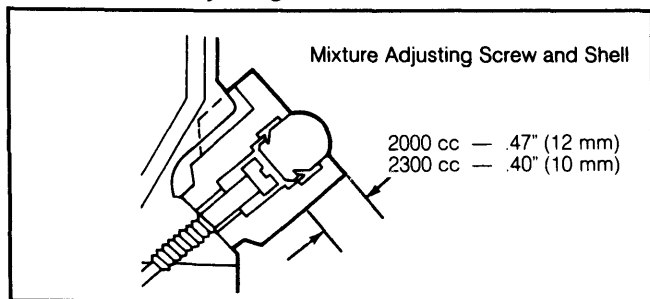

Cut off cap at depth shown. Install new blind plug after final adjustment has been made.

4) On California models, disconnect air bypass valve hose at check valve and plug valve port. On Federal models, disconnect air cleaner hose at reed valve and plug valve port.

5) On 2000 cc models, adjust speed to 20 RPM higher than mixture RPM by turning throttle adjusting screw. Adjust mixture screw to obtain highest possible RPM. Reset engine speed to 20 RPM higher than mixture RPM by turning throttle adjusting screw.

6) Turn mixture screw clockwise to obtain mixture RPM. If CO level is incorrect, turn mixture screw counterclockwise ¼ turn. Reconnect air hose and adjust to curb idle speed with throttle adjusting screw. Install mixture screw blind plug.

7) On 2300 cc models, adjust idle speed to mixture RPM by turning throttle adjusting screw. Check CO level and adjust as necessary by turning mixture screw. If idle speed changes, readjust mixture RPM with throttle adjusting screw and recheck CO percentage.

8) Reconnect air hose. If necessary, adjust idle speed to curb idle RPM. Install mixture screw blind plug.

IDLE SPEED & CO LEVEL

Application	Idle RPM	CO%
2000 cc		
Federal	650	1.0
Calif.	650	1.0
2300 cc		
Man. Trans.	850	3.5
Auto. Trans.	1 700	3.5

1 — With trans. in "D".

COLD (FAST) IDLE RPM

With choke valve fully closed, position fast idle screw on highest step of fast idle cam. Measure clearance between lower edge of throttle valve and wall of throttle bore. If clearance is not within specifications, adjust by turning screw clockwise to increase clearance, counterclockwise to decrease clearance.

FAST IDLE SPECIFICATIONS

Application	Clearance In. (mm)
2000 cc05 (1.3)
2300 cc06 (1.5)

FUEL PUMP

FUEL PUMP PERFORMANCE

Application	Pressure psi (kg/cm ²)	Volume in 30 Sec. Pints (Liters)
All Models	2.8-3.6 (.20-.25)	1.0 (0.5)

EXHAUST EMISSION SYSTEMS

See EXHAUST EMISSION SYSTEMS section.

1982 Courier 4 Tune-Up

GENERAL SERVICING

IGNITION

DISTRIBUTOR

All models are equipped with a Mitsubishi breakerless, electronic ignition system.

DISTRIBUTOR PICK-UP COIL RESISTANCE

Application	Ohms
2000 cc	1050
2300 cc	760-840

IGNITION COIL

RESISTANCE Ohms@68°F (20°C)

Application	Primary	Secondary
All Models	0.9-1.1	7000-9800

FUEL SYSTEMS

CARBURETOR APPLICATIONS

Engine	Model
2000 cc	Nikki 2-Bbl.
2300 cc	Hitachi DCS 328 2-Bbl.

ELECTRICAL

BATTERY

BATTERY SPECIFICATIONS

Application	Amp. Hr. Rating
All Models	
Standard	45
Optional	70

STARTER

All models use Nippondenso solenoid-actuated, overrunning clutch type starters.

STARTER SPECIFICATIONS

Application	Volts	Amps.	Test RPM
All Models	11	50	5000

ALTERNATORS

All models use a Mitsubishi alternator.

ALTERNATOR SPECIFICATIONS

Application	Rated Amp. Output
All Models	35

ALTERNATOR REGULATOR

All models are equipped with Mitsubishi alternators with built-in voltage regulators.

REGULATOR OPERATING VOLTAGE@68°F (20°C)

Application	Voltage
All Models	14.5-15.8

SERVICE SPECIFICATIONS

BELT ADJUSTMENT

Application	¹ Deflection In. (mm)
Fan Belt	0.3-0.6 (8-15)
Air Pump	0.5-0.7 (13-18)
Alternator/Air Pump	0.4 (10)

¹ — Deflection is with 22 lbs. (10 kg) pressure applied midway on belt.

REPLACEMENT INTERVALS

Component	Miles
Oil Filter	7500
Air Filter	30,000
Fuel Filter	15,000
PCV Valve	30,000
Spark Plugs	30,000

CAPACITIES

Application	Quantity
Crankcase (Includes Filter)	
2000 cc	4.7 qts. (4.4L)
2300 cc	5.0 qts. (4.7L)
Cooling System	
2000 cc	7.6 qts. (7.2L)
2300 cc	8.8 qts. (8.3L)
Man. Trans. (SAE 90 with EP)	
4-Speed	1.5 qts. (1.4L)
5-Speed	1.8 qts. (1.7L)
Auto. Trans. (Type F Trans. Fluid)	6.6 qts. (6.2L)
Rear Axle (Hypoid Gear Lubricant)	2.8 pts. (1.3L)
Fuel Tank	
Standard	14.8 gals. (56.0L)
Optional	17.5 gals. (66.2L)