

# Distributors & Ignition Systems

## NIPPONDENSO ELECTRONIC IGNITION SYSTEM

<b>Isuzu</b>	<b>1800 (2WD)</b>	<b>Land Cruiser</b>
<b>I-Mark</b>	<b>Toyota</b>	<b>Pickup</b>
<b>P'UP</b>	<b>Celica</b>	<b>Starlet</b>
<b>LUV</b>	<b>Corolla</b>	<b>Supra</b>
<b>Subaru</b>	<b>Corona</b>	<b>Tercel</b>
<b>1600 (2WD)</b>	<b>Cressida</b>	

### DESCRIPTION

Nippondenso electronic ignition system includes a breakerless distributor, an ignitor (ignition control unit), a special ignition coil, an ignition signal generating mechanism (pick-up coil assembly) and ignition switch.

The distributor consists of a housing, rotor and cap. It contains a timing rotor (reluctor), magnet, and pick-up coil assembly. A transistorized ignitor is separate from the distributor. See Fig. 1. Distributors contain conventional centrifugal and vacuum advance mechanisms.

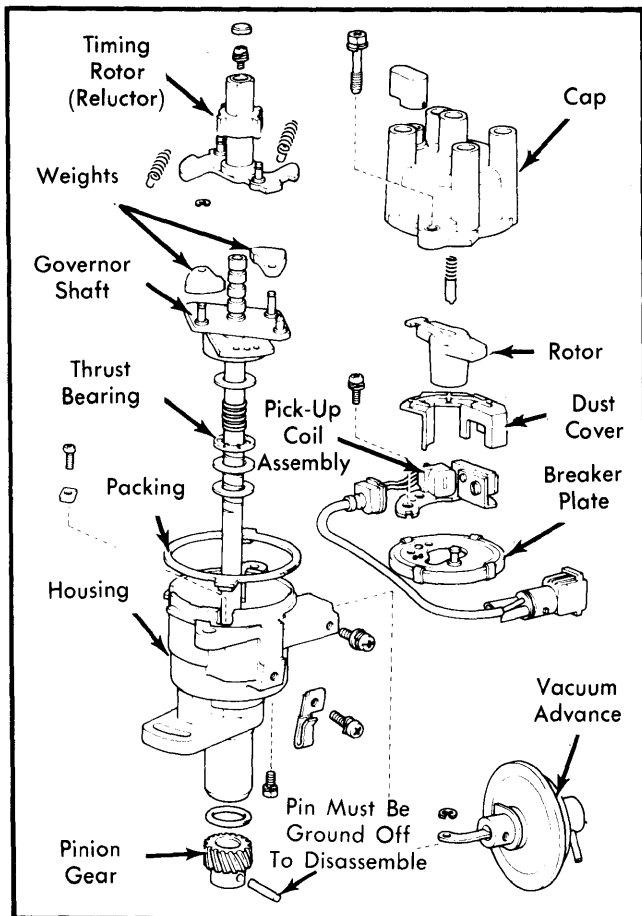

Fig. 1 Exploded View of Typical Nippondenso Distributor (Toyota Model Shown, Others Similar)

### OPERATION

As the timing rotor turns with the distributor shaft, its teeth (one for each engine cylinder) pass the pick-up coil assembly. See Fig. 2. As the air gap changes with the approach and passing of each tooth, the magnetic field varies. This creates a signal in the pick-up coil assembly.

The ignitor senses this signal and turns the ignition coil primary circuit on and off. This causes voltage to build and collapse,

resulting in a voltage surge in the secondary that fires the spark plugs.

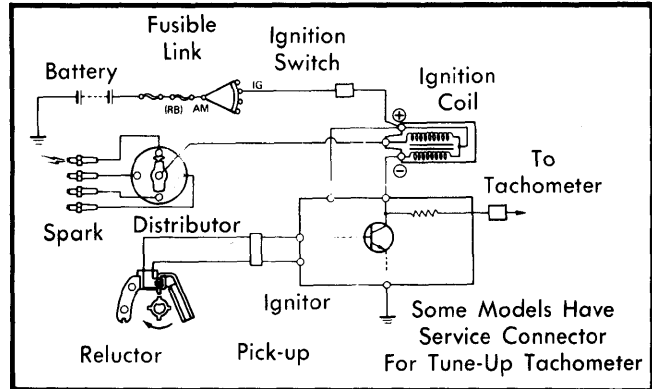

Fig. 2 Schematic of Celica & Corona Electronic Ignition Circuit (Other Models Similar)

### SPECIFICATIONS

Centrifugal & Vacuum Advance - See Specifications Tables in this section.

### ADJUSTMENT

**Timing Rotor (Reluctor)-to-Pick-Up Coil Air Gap** - Using a flat feeler gauge, check air gap. Gap should be .008-.016" (0.2-0.4 mm). If not, loosen screws and move pick-up coil against feeler gauge of proper thickness. Tighten screws and recheck air gap.

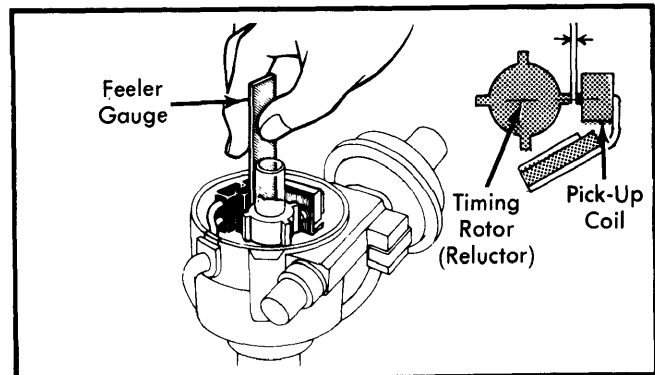

Fig. 3 Checking Timing Rotor-to-Pick-Up Coil Air Gap Using Feeler Gauge

### TESTING

**CAUTION** - Be sure all connections are correct, as reverse battery polarity within the system will damage the ignitor (ignition control unit). Do not disconnect battery while engine is running or transistors may be damaged. Do not allow water to enter ignitor. If a tachometer is connected to system, connect tachometer positive lead to coil negative terminal.

**CAUTION** - Be especially careful when checking Toyota systems, as a variety of ignition coil, ignitor, and resistor combinations are used. Connectors and wire colors also vary from model to model. Illustrations are for typical systems only.

## NIPPONDENSO ELECTRONIC IGNITION SYSTEM (Cont.)

### IGNITION COIL TEST

**NOTE** — All tests on the ignition coil are made with an ohmmeter with the ignition switch in the "OFF" position. If the resistance for any test is not within specifications, replace ignition coil.

**Primary Coil Resistance** — Connect an ohmmeter set in x1 range so leads touch coil positive and negative primary terminals (or connector terminals leading to them). See *Ignition Coil Resistance chart*.

**Secondary Coil Resistance** — Set an ohmmeter in the x100 range. Connect leads to coil primary terminal and to coil tower (high tension terminal). See *Ignition Coil Resistance chart*.

**Resistor Resistance** — Connect an ohmmeter, set in the x1 range, so that leads are connected to each side of resistor (or resistance wire), if equipped. See *Ignition Coil Resistance chart*.

Ignition Coil Resistance (Ohms)		
Application	Primary Resistance	Secondary Resistance
Isuzu & LUV .....	1.13-1.53 .....	10,200-13,800
Toyota		
Celica & Corona .....	0.8-1.1 .....	10,700-14,500
Corolla .....	0.8-1.1 .....	11,500-15,500
Cressida, Land Cruiser & Supra .....	0.5-0.7 .....	11,500-15,500
Pickup .....	0.4-0.5 .....	8,500-11,500
Starlet <sup>①</sup> .....	1.3-1.7 .....	10,000-15,000
Subaru <sup>②</sup> .....	1.06-1.30 .....	12,150-14,850
① — External resistor resistance	1.1-1.3 ohms.	
② — External resistor resistance	1.4-1.6 ohms.	

**Insulation Resistance** — Connect ohmmeter leads between coil positive terminal and mounting bracket of coil. Reading on all models should exceed 10,000 ohms (infinity).

**High Tension Wire Resistance** — Set ohmmeter to x1000 scale and attach leads to ends of high tension wire. On Isuzu and LUV, resistance should not exceed 73,500 ohms per foot. On all other models, resistance should not exceed 25,000 ohms. If it does, replace wires.

**Pick-Up Coil Resistance** — Measure pick-up coil resistance at distributor connector with ohmmeter. Check value against table.

Pick-Up Coil Resistance (Ohms)	
Application	Resistance
Cressida, Starlet & Supra .....	140-180
All Other Models .....	130-190

### IGNITOR TESTS

**NOTE** — Tests apply to Isuzu, LUV and Toyota models. Two different procedures are used for Toyota, depending on the model.

**Pickup & Starlet Models** — 1) Turn ignition switch "ON". On Pickup, disconnect Brown and Yellow wiring harness connectors. Connect voltmeter positive lead to the brown connector on wiring harness side.

2) On Starlet, remove coil cover. Connect voltmeter positive lead to resistor positive terminal and voltmeter negative lead to ground. All readings should be 12 volts.

3) On Pickup, reconnect Brown wiring harness connector. Connect voltmeter positive lead to Yellow connector (ignitor side). Connect negative lead to ignitor body. Reading should be 12 volts. On Starlet, connector voltmeter positive lead to coil negative terminal and negative lead to ground. Voltage should be less than 3 volts.

4) On all models, unplug wiring connector from distributor. Using a 1.5 volt dry cell battery, connect battery positive pole to Pink wire terminal and negative pole to White wire terminal. On Starlet, connect voltmeter positive probe to coil negative terminal and negative probe to ground.

5) On Pickup, connect voltmeter positive probe to Yellow connector (ignitor side) and negative probe to ground. Readings should be 7 volts.

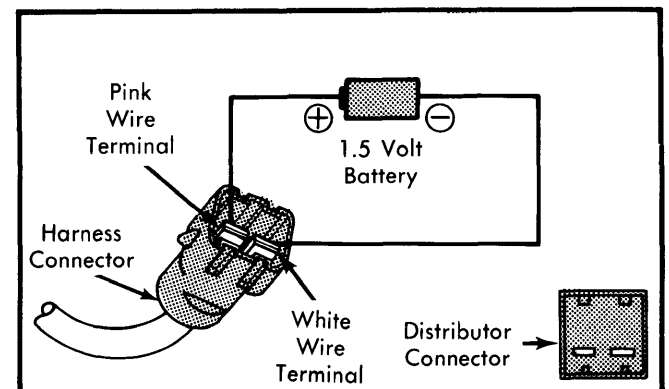

**Fig. 4** Checking Ignitor Operation with 1.5 Volt Battery

**Other Models** — 1) Turn ignition switch "ON". Connect negative voltmeter lead to ground and positive lead to ignition coil positive terminal. Voltage reading should be 12 volts.

2) Connect voltmeter positive lead to ignition coil negative terminal. Negative lead should still be attached to ground. Voltage should read 12 volts. Unplug wiring harness connector from distributor.

3) Using a 1.5 volt dry cell battery, connect battery positive pole to Pink wire terminal and negative pole to White wire terminal. Voltage at negative terminal of coil should read 7 volts for Toyota and 5 volts for Isuzu and LUV. If not, replace ignitor.

**CAUTION** — Do not apply voltage for more than 5 seconds.

### IGNITION SYSTEM TEST

**NOTE** — Although this information applies basically to Subaru models, the same principle applies to Toyota models with resistors or resistance wires.

1) Turn ignition switch "ON". Connect negative lead of a voltmeter to ground and positive lead (in turn) to each of the resistor terminals "a" and "b". One reading should be battery voltage, the other reading should be one half that voltage. If so, proceed to step 10).

2) If there was no voltage at either terminal in step 1), check wiring harness, connector, ignition switch and fuse between

## NIPPONDENSO ELECTRONIC IGNITION SYSTEM (Cont.)

battery and resistor. Check for broken wires, poor connections, and battery condition.

3) If there was voltage at only one of the resistor terminals in step 1), turn ignition switch "ON" and disconnect lead wire from terminal having no voltage. Check resistor terminal for voltage. If none, replace resistor. If voltage now exists, check wiring harness between resistor and positive terminal of ignition coil for short circuit. Repair or replace as necessary.

4) If there was voltage at both terminals, but one was not about one-half battery voltage, turn ignition switch "ON". Connect voltmeter negative lead to ground and positive lead to ignition coil negative terminal. Reading should be battery voltage.

5) If not, turn ignition switch "ON" and connect voltmeter negative lead to ground and positive lead to ignition coil positive terminal. Reading should be battery voltage. If not, replace ignition coil. If battery voltage is shown, check wiring harness between resistor and ignition coil positive terminal. Check for broken wires, poor connections and repair as necessary.

6) If voltage at ignition coil negative terminal in step 4), was battery voltage, turn ignition switch "OFF". Using an ohmmeter set in the x1 range, measure resistance between ignitor side and ground. Resistance should be less than 0.5 ohm. If not, check ground wire for proper contact at regulator bracket.

7) If resistance was less than 0.5 ohm in step 6), proceed to the next step, step 8).

8) Turn ignition switch "OFF". Disconnect 2-pin (Toyota) or 3-pin (Subaru) distributor connector. Disconnect high tension wire at distributor and hold it about 1/4" (6 mm) from engine block. Turn ignition switch "ON". Check if spark jumps when a small voltage (1-6 volts) is applied intermittently on terminals "1" (pink wire) and "2" (white wire) on ignitor side of connector.

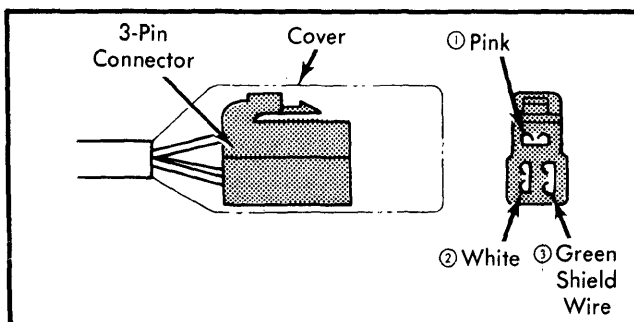

Fig. 5 Conducting Tests at Distributor Connector (Subaru Shown)

**CAUTION** — Do not use battery voltage (12 volts) for this test or ignitor may be damaged.

9) If spark jumps gap, there is no problem with the ignition system. If no spark occurs, replace ignitor.

10) If during step 1), the voltage at one resistor terminal was one-half that of the other, turn the ignition switch "ON". Connect negative lead of voltmeter to a good ground and

positive lead to ignition coil negative terminal. If reading is not below 0.5 volt, check wiring harness for shorts, check loose connections at coil negative terminal and repair as necessary. If no problem is found, perform steps 8) and 9) again.

11) If in step 10) reading was below 0.5 volts, turn ignition switch "OFF" and disconnect 2-pin connector. Using an ohmmeter set to x100 range, connect leads to terminals "1" (Pink wire) and "2" (White wire) of distributor connector (distributor side).

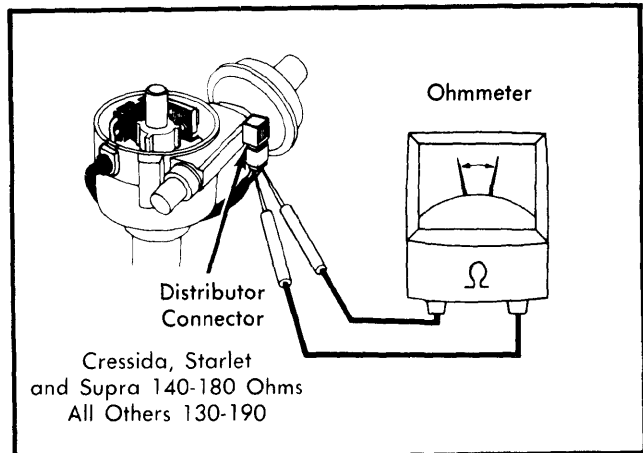

Fig. 6 Check Pick-Up Coil Resistance With Ohmmeter

12) If resistance reading is incorrect, replace pick-up coil assembly. If correct, turn ignition switch "OFF" and check timing rotor (reluctor)-to-pick-up coil air gap. If not .008-.016" (0.2-0.4 mm), adjust as necessary. If air gap is correct, perform steps 8) and 9) again.

## OVERHAUL

**NOTE** — Procedure is general only. Some models may differ slightly.

**Disassembly** — 1) Remove distributor cap rotor, dust cover, and packing. Remove pick-up coil assembly, vacuum advance mechanism, breaker plate and drive pinion.

2) Remove 2 screws from bottom of distributor housing and using a plastic hammer, carefully drive out shaft. Remove thick washer, bearing, thin washer, spring, and blue washer from shaft.

3) Remove governor springs, cam cap, timing rotor (reluctor), weight snap ring and weights.

**Reassembly** — Assemble in reverse order of disassembly, noting the following:

- Lightly grease timing rotor (reluctor) inner surface. Install on shaft aligning mark on stopper plate ("10.5" on Isuzu and LUV, "15.5" on Subaru, "12" on Celica, Corona and Pickup, "10" on Corolla, "14" on Starlet, "8" on Supra and Cressida, and "11.5" on Tercel).
- When installing breaker plate, align 4 clips of plate with 4 grooves in housing.
- When replacing pinion, replace pin and pinion as a set. Adjust air gap between timing rotor and pick-up coil.