

# Distributors & Ignition Systems

## HITACHI ELECTRONIC IGNITION SYSTEM – SUBARU

1800 (4-WD Models)

### DESCRIPTION

The Hitachi electronic distributor consists of a housing, rotor and distributor cap. See Fig. 1. A reluctor, mounted on the shaft and governor assembly, combines with the pick-up coil to replace the conventional cam and breaker points. With the ignition switch "ON", the distributor reluctor rotates past the pick-up coil/control unit. As each tooth of the reluctor approaches and passes the pick-up coil/control unit, a signal is sent to the control unit. The control unit then turns the primary circuit in the ignition coil on and off as each tooth passes the pick-up coil. This causes a build-up and collapse of a magnetic field in the coil, resulting in a high voltage surge in the coil's secondary circuit. This fires the spark plugs. See Fig. 2.

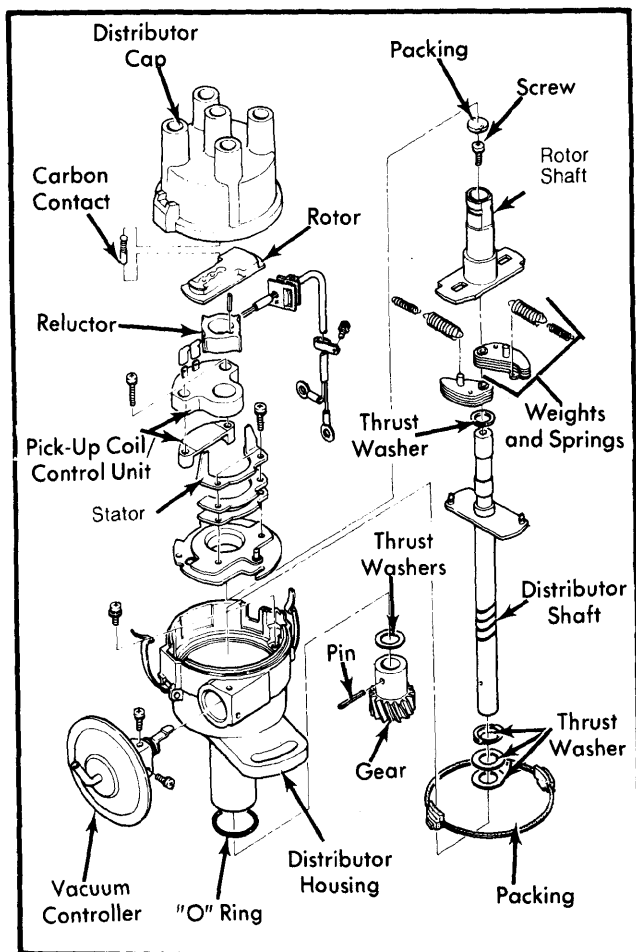

Fig. 1 Disassembled View of Hitachi Distributor for Subaru 4-Wheel Drive Vehicles

### SPECIFICATIONS

**Centrifugal & Vacuum Advance** – See Specification Tables in this section.

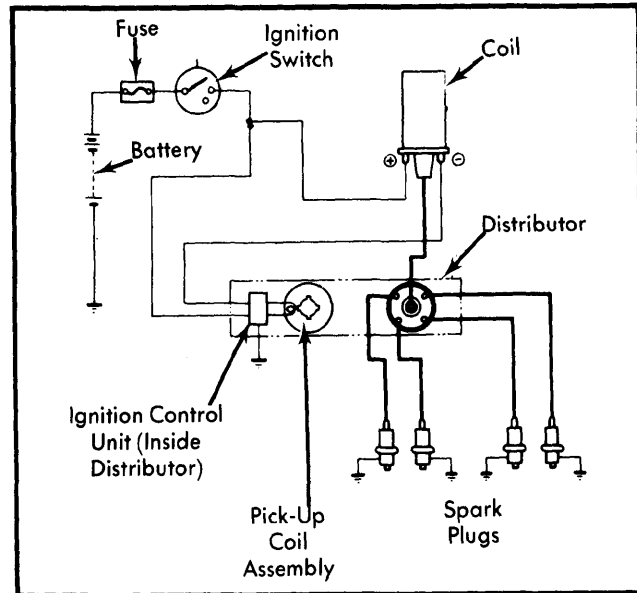

Fig. 2 Schematic of Ignition Circuit for Subaru 4-Wheel Drive Vehicles

### ADJUSTMENTS

**Air Gap** – Align teeth of reluctor with stator. Loosen stator hold-down screws. Insert a .016" (.4 mm) feeler gauge between teeth and stator. Adjust stator against gauge and tighten hold-down screw. Air gap should be .012-.020" (.3-.5 mm). See Fig. 3.

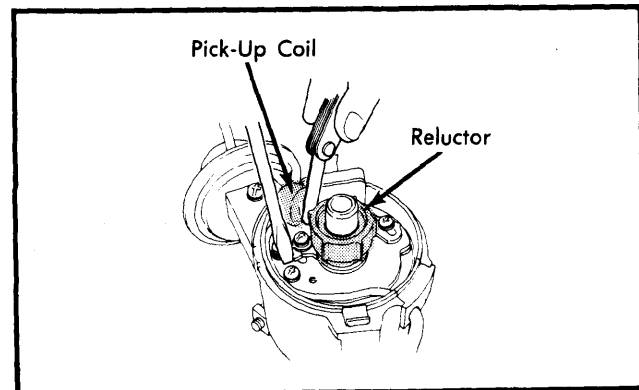

Fig. 3 Adjusting the Air Gap

### TESTING

1) Turn ignition switch "ON". Connect negative lead of voltmeter to ground and positive lead to negative terminal of ignition coil. Voltage should be within 1 volt of battery voltage. If not, proceed to step 8).

2) If reading was within 1 volt of battery voltage, turn ignition switch "OFF" and disconnect 2-pole connector. See Fig. 4.

## HITACHI ELECTRONIC IGNITION SYSTEM – SUBARU (Cont.)

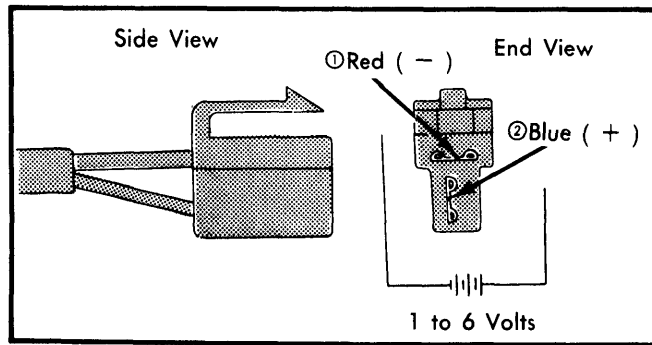

**Fig. 4 Conducting Tests at 2-Pole Connector**

3) Using an ohmmeter set at the x100 scale, measure resistance between the terminals in the distributor side of the 2-pole connector. Reading should be 600-850 ohms. If not, replace pick-up coil.

4) If reading was within specifications, turn ignition switch "OFF". Using an ohmmeter set to the x1 scale, measure resistance between ground and ignition control unit side. Resistance should be less than .5 ohm. If not, check ground wire at regulator mounting screw.

5) If less than .5 ohm, turn ignition switch "OFF" and check air gap between reluctor and pick-up coil. Adjust as necessary.

6) If air gap was originally within specifications, turn ignition switch "OFF" and disconnect 2-pole connector. Disconnect secondary wire from distributor and hold  $\frac{1}{4}$ " from engine ground. Turn ignition switch "ON" and check whether spark jumps when a small voltage (1-6 volts) is intermittently applied to terminals 1 and 2 on ignition control unit side of connector.

**NOTE** — Do not use battery voltage for this test or damage may occur to ignition control unit.

7) If spark occurs, there is no trouble with ignition system. If no spark occurs, replace ignition control unit.

8) If the reading in step 1) was not within 1.0 volt of battery voltage, turn ignition switch "ON" and check voltage at positive terminal of ignition coil. If not equal to battery voltage, check wiring between ignition switch and positive terminal of ignition coil. Repair or replace as necessary. If OK, check connector, switch, fuse and wiring back to the battery.

9) If reading at coil positive terminal was within 1.0 volt of battery voltage, disconnect the lead at negative terminal (coming from ignition control unit). Turn ignition switch "ON". Voltage at negative terminal should be within 1.0 volt of battery voltage.

10) If voltage is within 1.0 volt of battery voltage, but engine will not start, replace ignition control unit. If not within 1.0 volt, remove lead from tachometer (if equipped) at ignition coil. Turn ignition switch "ON" and again check voltage at negative terminal of coil.

11) If reading is now correct, but engine will not start, check wiring harness from negative terminal of coil to tachometer for short circuit. If in step 10), reading was still not within 1.0 volt of battery voltage, replace ignition control unit.

12) If ignition coil is suspected of being defective, check primary and secondary coil resistance. To check primary coil resistance, attach leads of an ohmmeter set in x1 range to coil primary terminals. Reading should be 1.04-1.27 ohms.

13) To check secondary resistance, set ohmmeter to x1000 range and attach leads to coil negative terminal and coil tower. Reading should be 7,360-11,040 ohms. If either reading is not to specifications, replace ignition coil.

## OVERHAUL

**Disassembly** — 1) Remove distributor cap and rotor. Remove vacuum controller by loosening screws and pulling vacuum controller out of distributor housing. Disconnect electrical wires from control unit, then remove wires from distributor housing.

2) Remove gear from distributor shaft by driving out pin. Remove thrust washers with gear. Remove screws attaching pick-up coil plate to distributor housing. Pull pick-up coil with distributor shaft from housing.

3) Remove dust-proof packing from top of distributor shaft. Remove screw from top of shaft, then pull lower distributor shaft out of upper shaft/pick-up coil plate assembly. Remove centrifugal weights and springs from lower distributor shaft.

**Reassembly** — Reassemble in reverse order of disassembly, noting the following:

- When installing rotor assembly, match notch in pick-up coil base with groove end of housing.
- When installing vacuum controller, tighten only the screw holding the controller to the housing. Tighten screw between lever and pick-up coil base when installing pick-up coil.
- When installing pick-up coil, adjust air gap to specifications.
- Position rotor shaft so flat side is centered on pole piece of pick-up coil. See Fig. 5.
- Align match mark "A" on pinion gear with right side of notch "B" on lower end of housing. See Fig. 5.
- After assembly, check centrifugal advance by using a distributor tester.

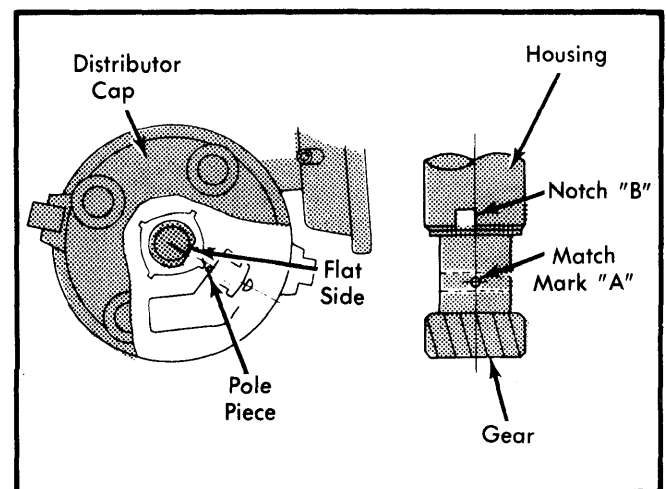

**Fig. 5 Aligning Rotor Shaft With Pole Piece and Pinion Gear With Housing**