

BOSCH SINGLE BREAKER DISTRIBUTOR

Audi

4000 (Fed. Man. Trans.)

Volkswagen

Vanagon (Federal)

DESCRIPTION

Conventional single breaker distributor with centrifugal advance and vacuum advance and/or retard unit. Vacuum units may be single or dual diaphragm and are linked to the moveable portion of the breaker plate assembly to advance or retard spark.

NOTE — Some distributors may use a dual diaphragm unit to provide retard only (vacuum advance side not used.)

SPECIFICATIONS

Point Gap & Cam Angle — See Tune-Up Data on Car Model Tune-Up Pages.

Centrifugal & Vacuum Advance (Or Retard) — See Specification Tables in this section.

ADJUSTMENT

Point Gap, Alignment, & Cam Angle — With rubbing block on high point of cam lobe, insert a feeler gauge blade between contacts and check reading against specification. To correct, loosen retaining screw and move stationary contact point until correct gap is obtained, then tighten screw. Align points if necessary by bending stationary contact support only. Check cam angle with a dwell meter; compare indicated reading with specification and correct if necessary.

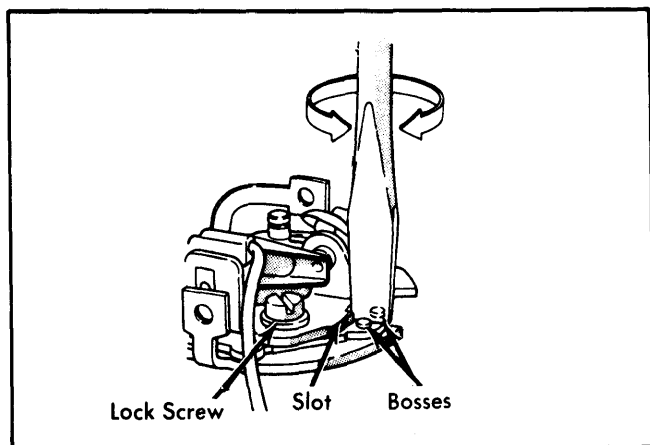

Fig. 1 Adjusting Contact Points

Breaker Arm Spring Tension — To check spring tension, place hook end of spring scale as close as possible to the movable breaker point. Pull scale at a right angle (90 degrees) to the movable arm and note reading just as points begin to open.

Centrifugal Advance — 1) Check distributor in test stand according to test equipment manufacturer's instructions. Operate distributor both up and down the RPM range and check advance at all RPM settings specified. Adjust or replace springs, weights or cam as necessary.

2) If distributor has adjustable driving collar for centrifugal advance, disassemble and lift shaft out. See Fig. 2. It is not necessary to remove breaker cam assembly from shaft. To adjust, loosen screws retaining driving collar. If collar is turned in direction of rotation, the advance curve rises. Turning collar in opposite direction of rotation will lower the curve.

CAUTION — Centrifugal advance curve must not be adjusted by bending spring clamps of driving collar.

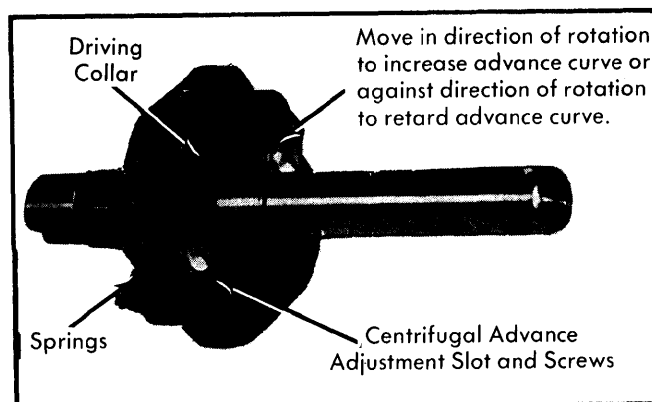

Fig. 2 Centrifugal Advance Adjustment (Driving Collar)

3) If distributor does not have adjustable driving collar, adjustment may be made by bending spring anchor tabs to modify spring tension (see illustration). To adjust for low speed operation, bend primary spring anchor tab outward to decrease advance, and inward to increase advance. For high speed operation, bend secondary spring anchor tab in or out to obtain specified settings.

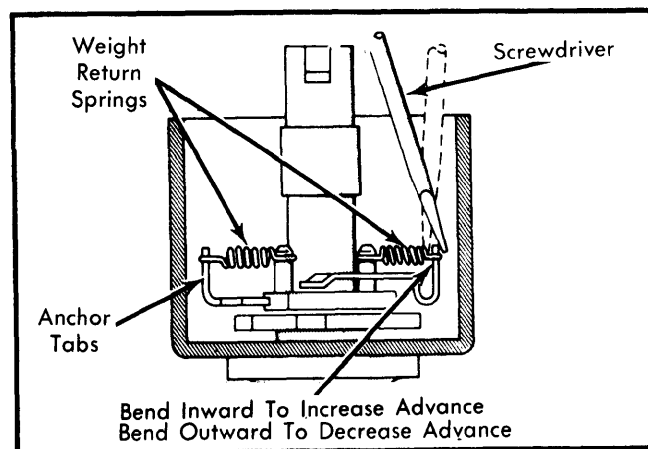

Fig. 3 Centrifugal Advance Adjustment (Spring Anchor Tabs)

Vacuum Advance — 1) With distributor in test stand, check advance at vacuum settings shown in specifications. If tests indicate vacuum diaphragm unit is inoperative, out of calibration, or leaking, replace vacuum unit.

2) Most types of vacuum diaphragm units are factory pre-set and cannot be adjusted. However, on some dual diaphragm vacuum units, the vacuum advance may be increased or decreased by turning an Allen screw located in end of diaphragm unit.

Distributors & Ignition Systems

BOSCH SINGLE BREAKER DISTRIBUTOR (Cont.)

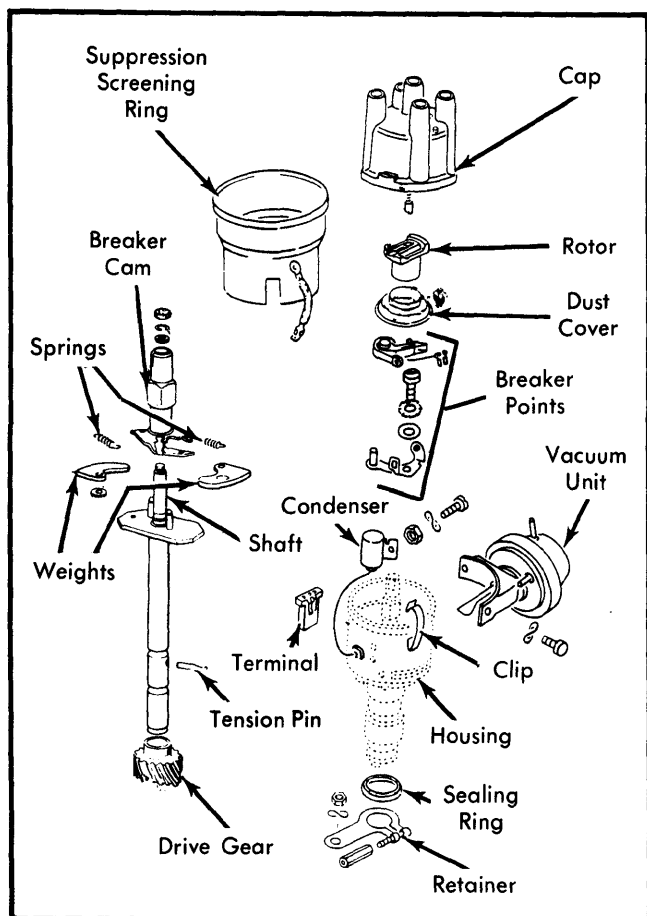

Fig. 4 Disassembled View of Bosch Distributor

Vacuum Retard — 1) With distributor in test stand, check retard at vacuum settings shown in specifications. If tests indicate vacuum diaphragm unit is inoperative, out of calibration, or leaking, replace vacuum unit.

2) Most types of vacuum diaphragm units are factory pre-set and cannot be adjusted. However, on some dual diaphragm units, the maximum vacuum retard setting may be raised or lowered if necessary by turning an eccentric, located at side of vacuum unit. See Fig. 5.

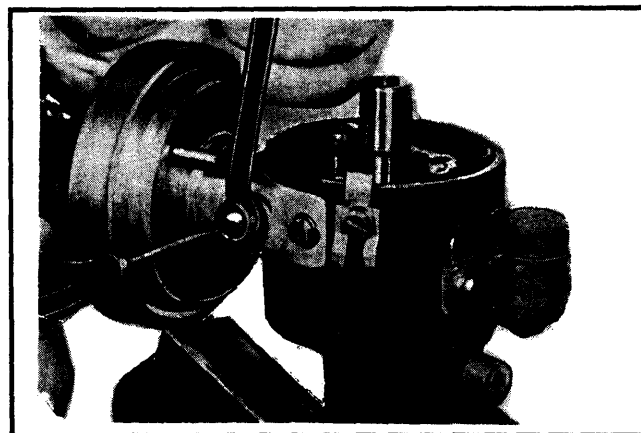

Fig. 5 Adjusting Maximum Vacuum Retard (Eccentric Location)

OVERHAUL

NOTE — All parts should be marked or set aside separately or in groups so that same combination can be reinstalled. Keep screws with the component they attach, as screws are different lengths and damage could occur if installed in wrong position.

Disassembly — 1) Disconnect and remove vacuum unit. Remove breaker points and condenser, then remove breaker assembly. Note positioning of centrifugal advance parts and mark for assembly reference. Disconnect and remove centrifugal advance springs (do not distort). Using 2 screwdrivers, carefully pry upward on the lower edge of breaker cam to disengage cam retaining ring. Lift cam, washer, retaining ring and lubricating felt pad from shaft, then remove advance weights.

2) Drive out retaining pin, then remove coupling (or gear) from end of distributor shaft. Remove shaft from distributor housing.

Reassembly — Install centrifugal weights and breaker cam on distributor shaft, then install advance springs. Secure breaker cam with washer and retaining ring, then install lubricating felt pad. Install shaft in distributor housing. Complete reassembly by reversing disassembly procedure.