

RENAULT THERMOSTATIC AIR CLEANER

Le Car

NOTE — Renault 18i models are equipped with fuel injection and do not use a thermostatic air cleaner.

DESCRIPTION

This device prevents fuel system icing and reduces emissions by controlling the temperature of air entering the combustion chamber. The system works through a temperature sensitive thermostatic element which is connected to a flap which directs either manifold-heated air or cooler outside air into the air cleaner housing.

OPERATION

When the intake air temperature is below 66°F (19°C), the thermostatic element contracts and closes off outside air. Only air from the exhaust manifold shroud will enter the air cleaner housing. Above 95°F (35°C), the element will have expanded so that the warm air path is closed and only outside air is taken in.

TESTING

- 1) Remove the air filter housing and filter element.
- 2) Dip the filter housing into cold water as deep as the thermostatic element.

3) After being immersed for 5 minutes in water below 66°F (19°C), the air flap should have closed off the cold air passage.

4) Heat water to above 95°F (35°C). After a short time, the thermostatic element should expand and the flap should close off the hot air intake passage.

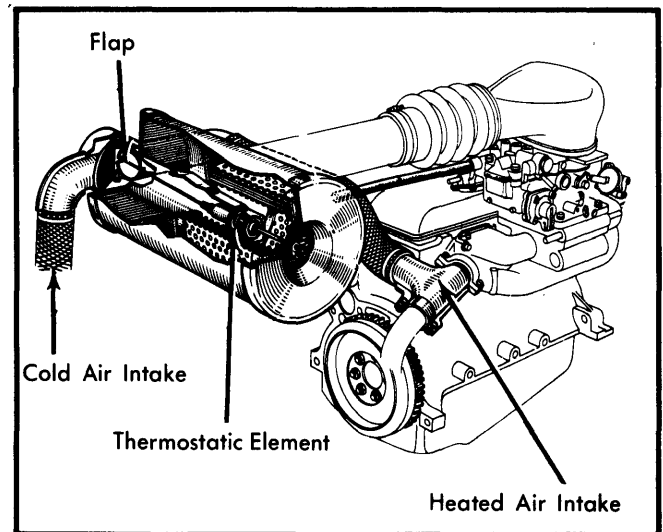

Fig. 1 Le Car Thermostatic Air Cleaner