

LUV CATALYTIC CONVERTER AND OVER-TEMPERATURE CONTROL SYSTEM

Pickup

DESCRIPTION

LUV models use a catalytic converter on all California vehicles to reduce hydrocarbon and carbon monoxide emissions. The converter is mounted in front of muffler in exhaust system.

On California vehicles an over-temperature control system is used to sense catalyst temperature and help prevent temperature buildup. Over-temperature control system consists of a thermo sensor, thermo controller, vacuum switching valve, air switching valve, coasting fuel cut device, and engine speed sensor.

OPERATION

Catalytic converter oxidizes exhaust gases into harmless non-polluting gases. The over-temperature control system components work as follows:

- While coasting, coasting fuel cut device is engaged to prevent rich mixtures from reaching converter.
- When converter reaches about 1350°F (730°C), due to high load conditions, air pump system air is diverted to atmosphere via action of the air switching valve and vacuum switching valve. This helps reduce chemical reaction in catalyst, which would create even higher temperatures.

VACUUM SWITCHING VALVE

This electro-vacuum valve contains a solenoid. When solenoid is activated by converter high temperature condition (1350°F or more), intake manifold vacuum passes through vacuum switching valve and connects with air switching valve to dump air pump air. When de-energized, solenoid allows intake manifold vacuum to pass to air switching valve and connect normal passages of air pump-to-injection manifold.

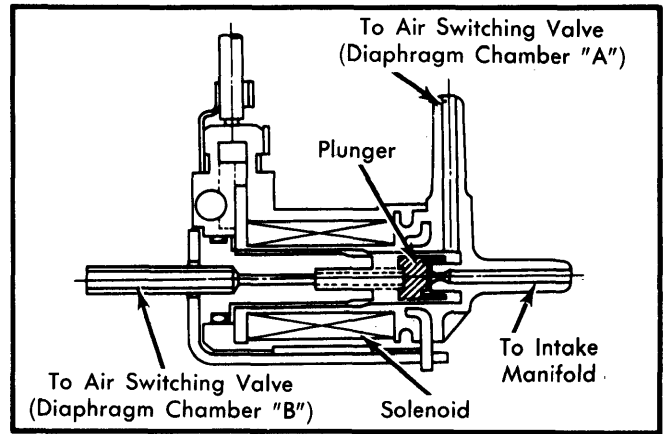

Fig. 2 Sectional Drawing of Vacuum Switching Valve

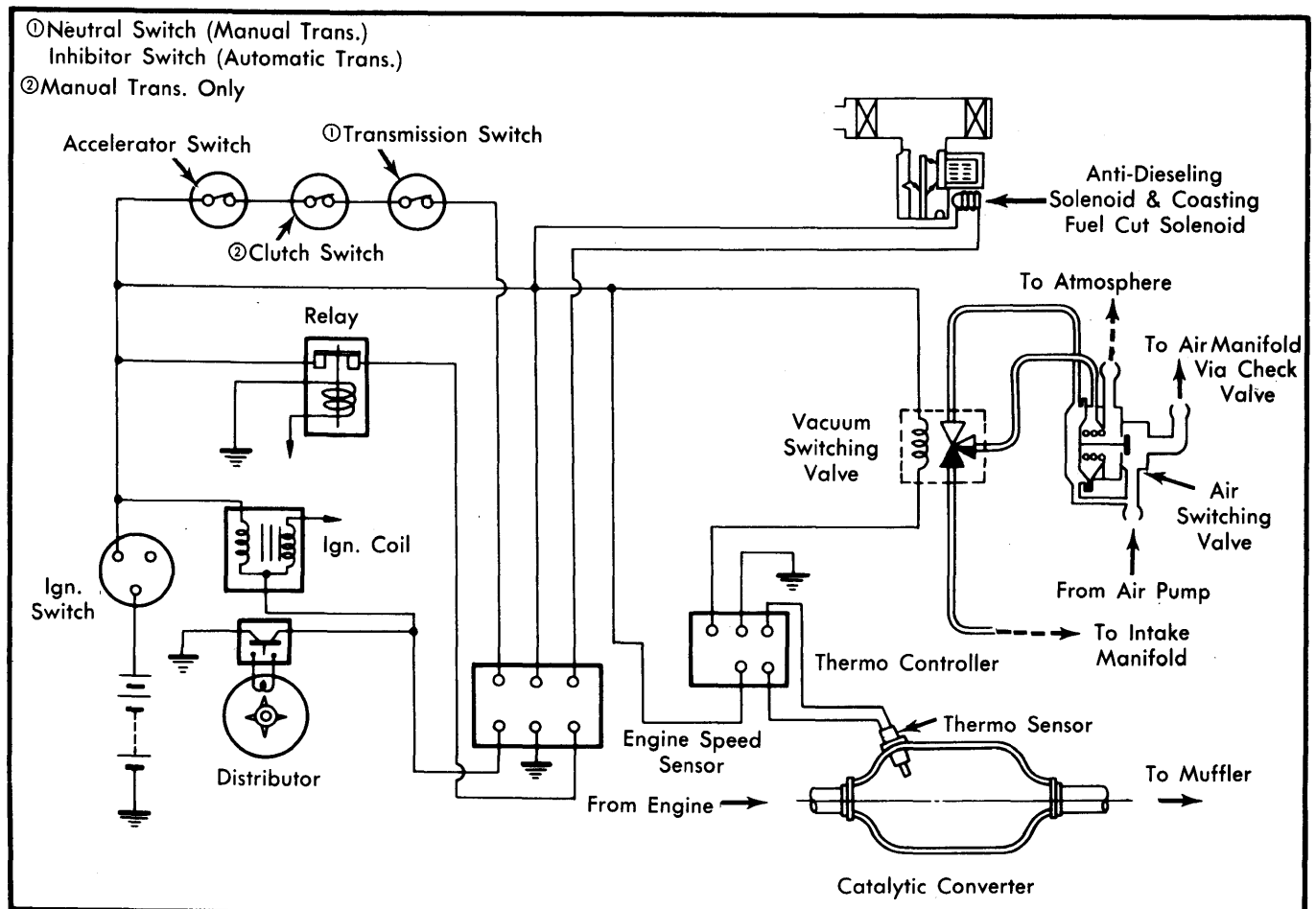

Fig. 1 Catalytic Converter and Over-Temperature Control System (California Only)

LUV CATALYTIC CONVERTER AND OVER-TEMPERATURE CONTROL SYSTEM (Cont.)

AIR SWITCHING VALVE

When air is directed to Chamber "B" from vacuum switching valve, air pump air is diverted to atmosphere, to protect converter. When vacuum reaches Chamber "A", normal air pump air passage occurs.

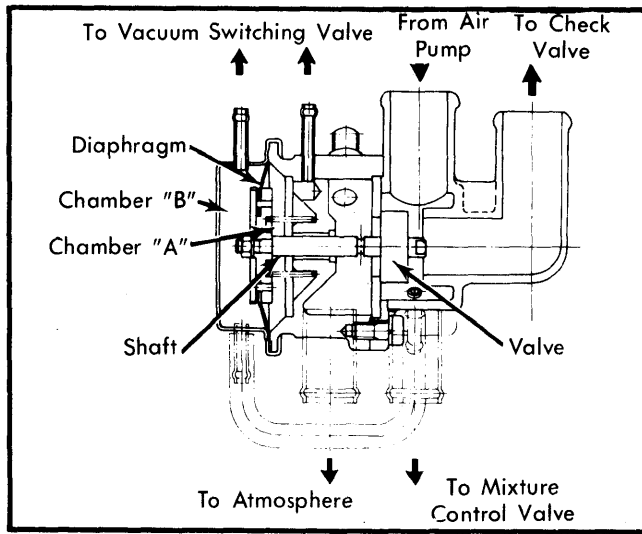

Fig. 3 Air Switching Valve Sectional View

NOTE — For related information about Air Injection System, see "LUV Air Injection System" article.

THERMO SENSOR AND THERMO CONTROLLER

Thermo sensor is inserted into converter, in a special stainless steel sheath, to determine converter temperatures. This device sends "on" or "off" electrical signals to the thermo controller, which sends signal to energize or de-energize solenoid portion of vacuum switching valve.

COASTING FUEL CUT DEVICE

A fuel cut solenoid (which also acts as anti-dieseling solenoid) is mounted on carburetor. It is connected in series with several switches to detect engine coasting conditions. When coasting is sensed, solenoid valve (installed on primary side of carburetor) is energized, closing throttle valve and stopping fuel flow. This protects converter against poor combustion conditions caused by rich mixture.

On Man. Trans. models, accelerator switch, clutch switch, transmission neutral switch and engine speed switch are used. On Auto. Trans. models, accelerator switch, inhibitor switch and engine speed switch are used. See Fig. 7.

TESTING

VACUUM SWITCHING VALVE

With valve removed from vehicle, apply electrical power (12 volts) to connector terminals and listen for clicking of solenoid as it moves inside valve. If no clicking is heard, select a new valve and repeat check.

AIR SWITCHING VALVE

With vacuum switching valve installed and 12 volts applied as described above, start engine. If air switching valve is okay, air will flow from atmospheric outlet of air switching valve. If not, replace valve.

THERMO SENSOR

Run engine at idle for a few minutes. Disconnect thermo sensor connector. Check for continuity between connector terminals of thermo sensor (use a test lamp or ohmmeter). If no continuity exists, replace thermo sensor.

ENGINE SPEED SENSOR

Connect BLK/YEL and LT.GRN/WHT wiring terminals at speed sensor connector, using jumper wires. Start engine and check for voltage between LT.GRN and BLK terminals. Voltage should drop to zero when engine speed is over 2100-2300 RPM.

ACCELERATOR SWITCH AND CLUTCH SWITCH

1) Adjust accelerator switch so clearance between accelerator switch lock nut and accelerator pedal bracket is $\frac{1}{2}$ " (12.7 mm). Adjust clutch pedal switch so clutch pedal switch is $\frac{3}{8}$ " (10 mm) higher than the brake pedal.

2) Detach wiring from accelerator switch and attach suitable continuity tester. Operate pedal, noting that continuity exists when pedal is released and no continuity is present when pedal is depressed. Repeat test with clutch switch. Replace if malfunctioning.

TRANSMISSION SWITCH (FED.) AND TRANS. NEUTRAL SWITCH (CALIF.)

Check switch by moving gearshift lever, with wiring detached and tester hooked to connector. If tester indicates switch is on when in 3rd or 4th (Federal) or any gear except neutral (Calif.), switch is okay. If not, replace switch.