

1981 Fuel Evaporation Systems

FIAT

Brava
Spider 2000
Spider 2000 Turbo
Strada
X1/9

DESCRIPTION

The fuel evaporation system is designed to prevent fuel vapors from entering the atmosphere. The system includes a sealed filler cap, fuel tank with expansion space, liquid/vapor separator, 2-way valve, and charcoal canister. Strada and X1/9 models have an additional 2-way safety relief valve, and Spider 2000 Turbo models use a check valve in the line between intake manifold and canister.

OPERATION

Fuel vapors pass from the tank into the charcoal canister, where they are adsorbed by activated charcoal. When the engine is running, vacuum is pulled through the canister, purging the fuel vapors. The 2-way valves provide air to vent the fuel tank and act as a safety valve to prevent tank over-pressure from fuel expansion. Turbo models use a check valve in the purge line to prevent the turbocharger from pressurizing the canister.

MAINTENANCE

Check all components and fuel lines for proper routing and tight connections.

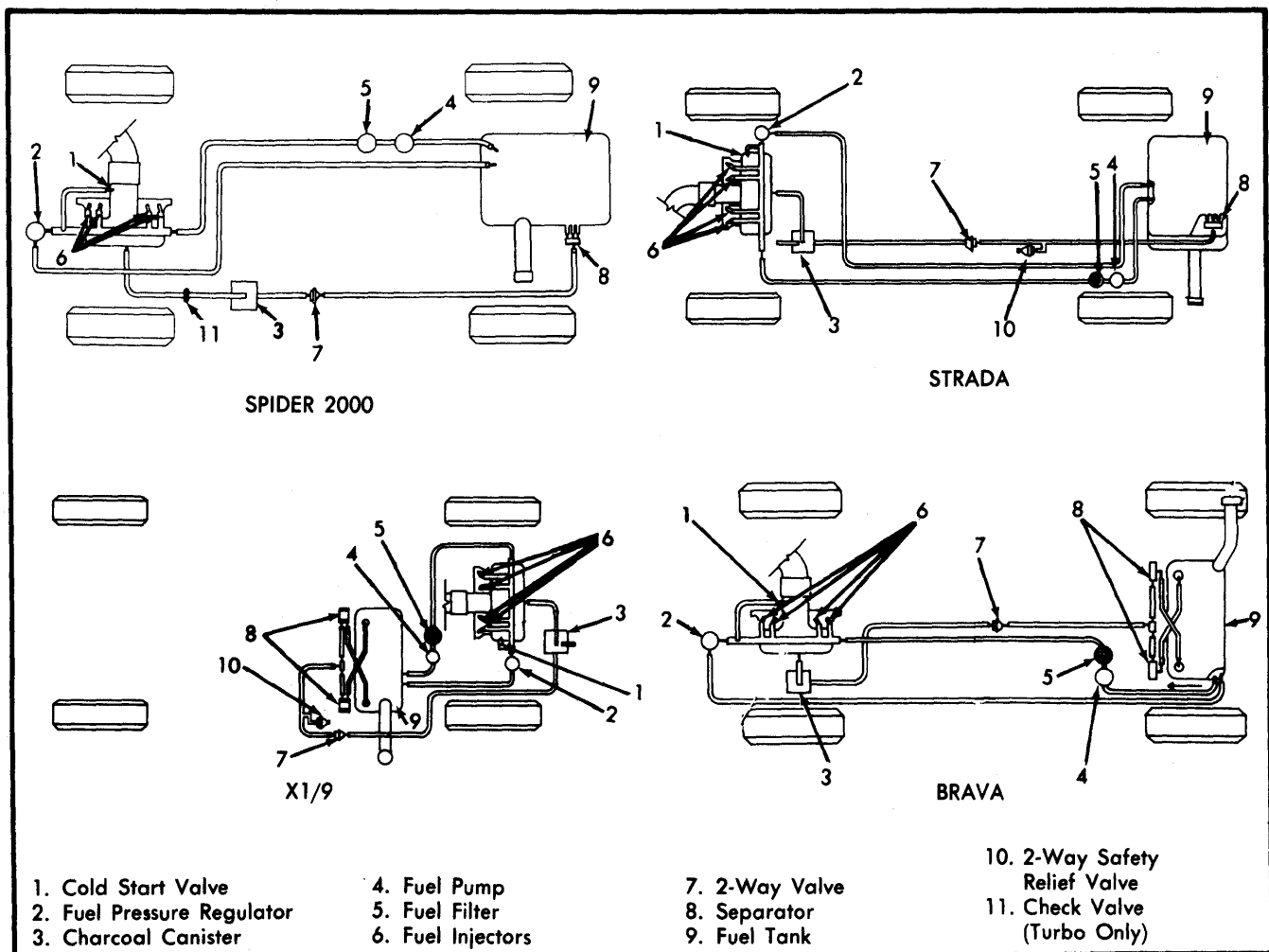

Fig. 1 Fiat Fuel Evaporation System Components