

# 1981 Fuel Evaporation Systems

## BMW

320i  
528i  
633CSi  
733i

## MAINTENANCE

The fuel evaporation system is maintenance free, but hose connections and fuel cap should be checked every 15,000 miles.

### DESCRIPTION

BMW Evaporative Control System consists of a purge system, leading from fuel tank to hose of crankcase ventilation system. Located between fuel tank and crankcase ventilation system is a vapor storage tank and an activated carbon canister. Fuel evaporation emissions are prevented from entering atmosphere by means of a sealed filler cap on fuel tank. Fuel tank has no direct vent to atmosphere. An excess fuel return valve is also used, located in fuel supply line near carburetor. A fuel return line connects this valve to fuel tank.

### OPERATION

When engine is off, fuel vapors are collected in vapor storage tank. Some vapors are condensed in storage tank and flow back into fuel tank. Excess vapors continue to charcoal canister, where they are absorbed. When engine is started, vacuum in intake manifold draws vapor from canister and storage tank. These vapors are then drawn into the engine and burned. Vapor storage tank also allows for fuel expansion of a completely filled fuel tank.

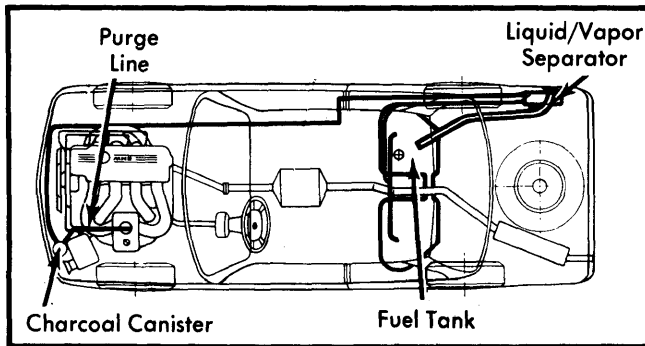

**Fig. 1 320i Fuel Evaporation System**

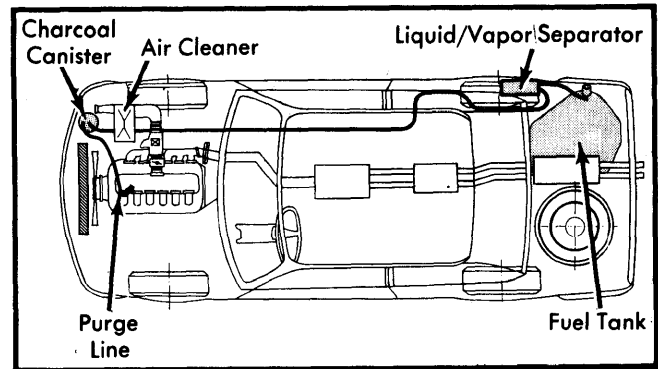

**Fig. 2 528i and 633CSi Fuel Evaporation System**

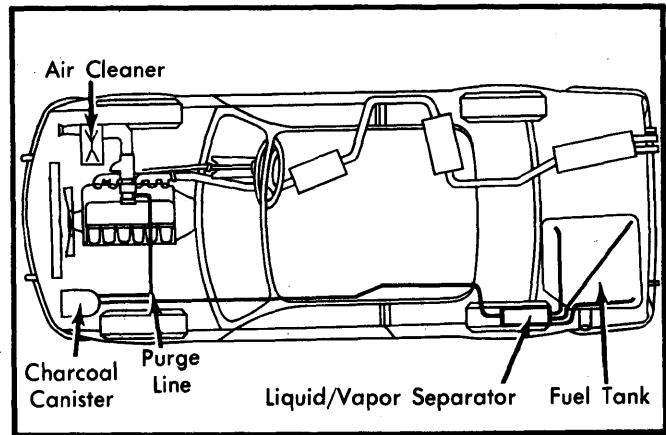

**Fig. 3 733i Fuel Evaporation System**