

MITSUBISHI ELECTRIC FUEL PUMP

Datsun
200SX
280ZX
280ZX Turbo
810

DESCRIPTION

The fuel pump is a wet type where the vane rollers are directly coupled to a motor filled with fuel. A relief valve in the pump is designed to open when pressure in the fuel line rises

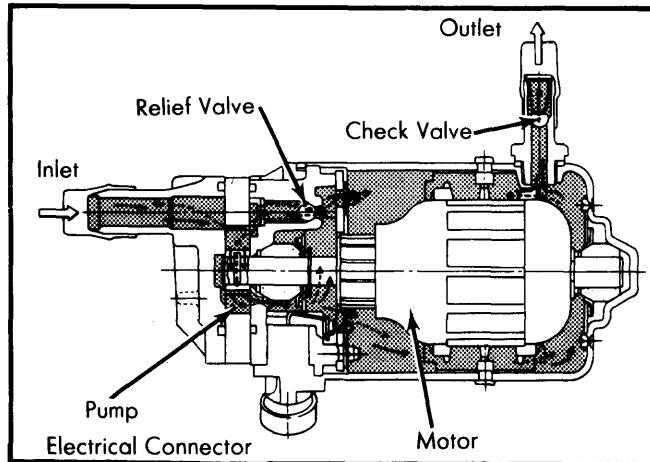

Fig. 1 Sectional View of Mitsubishi Electric Fuel Pump

above 43-64 psi (3.0-4.5 kg/cm²). A check valve on the fuel pump outlet prevents an abrupt drop in pressure in the fuel lines when the engine is stopped.

OPERATION

The fuel pump is actuated by a fuel pump relay when the ignition switch is in the "START" or "ON" position. As fuel goes through the pump, it is routed to a fuel damper mounted near the fuel pump. The damper reduces pulsations in the fuel lines. The fuel pump and damper are mounted just in front of the fuel tank on all models.

REMOVAL & INSTALLATION

Removal — 1) Disconnect negative battery cable at battery. Make sure that there is no pressure in fuel lines. Raise rear of vehicle and support with safety stands. Clamp hose between fuel tank and pump. Remove fuel hose clamps at inlet and outlet hoses on pump.

2) Disconnect fuel hoses from fuel pump. Disconnect harness connector from fuel pump. Remove bolts that attach fuel pump bracket to body. Remove fuel pump and fuel damper from vehicle as an assembly. Separate fuel damper from fuel pump.

Installation — Reverse removal procedures.

SUBARU ELECTRIC FUEL PUMP

DESCRIPTION & OPERATION

The Subaru electric fuel pump is an electromagnetic plunger type pump. The pump is located in the engine compartment. It is mounted on a bracket that is attached to the left front strut tower. The fuel pump is actuated when the ignition switch is in the "START" or "ON" position. A check valve, located on the fuel pump outlet, prevents fuel from returning to the fuel tank when engine is turned off.

TESTING

Before performing the following tests, be sure that hose connections are tight and not leaking, be sure that electrical connection is clean and tight. Confirm that pump makes an operating sound when actuated.

Output Pressure — Disconnect fuel hose from carburetor. Connect a pressure gauge to fuel hose. Measure output pressure while operating fuel pump. Pump output pressure should be 1.3-2.0 psi (.09-.14 kg/cm²). If output pressure is not within the specified range, replace the fuel pump.

Suction Pressure — Disconnect fuel hose between fuel filter and pump at the filter. Place finger over end of hose. Suction should be felt when fuel pump is actuated. If no suction is felt, replace fuel pump.

REMOVAL & INSTALLATION

Removal — Disconnect wiring harness from fuel pump. Remove 2 screws that attach fuel pump bracket to left front strut tower. Remove screws that attach fuel pump to fuel pump bracket. Disconnect fuel hoses from fuel pump. Remove fuel pump from vehicle.

Installation — Reverse removal procedures and note the following: Hose from fuel filter goes to the left side of the fuel pump, and the fuel hose from carburetor goes to the right side.

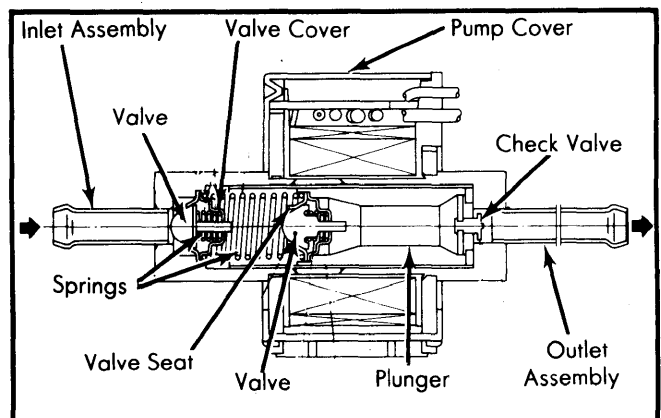

Fig. 1 Sectional View of Subaru Electric Fuel Pump