

# 1981 Electric Fuel Pumps

## ISUZU ELECTRIC FUEL PUMPS

**Chevrolet LUV  
Gasoline Models Only  
Datsun Pickup  
Gasoline Models Only**

**Isuzu  
I-Mark  
Gasoline Models Only  
P'UP  
Gasoline Models Only**

30-45 seconds until the fuel is used up in the carburetor float bowl.

**Pickup Models** — The 12 volt electrical circuit is protected by fuses and is controlled by a fuel pump relay mounted on the right front inner fender. This relay is controlled by alternator output when engine is running. When engine is off, power is fed through transmission switch (when closed for starting) directly to the fuel pump circuit of the relay.

### DESCRIPTION

Electric fuel pump is mounted to the left side frame rail adjacent to the fuel tank on Pickup models or near the bottom of the fuel tank on I-Mark models. No internal pump components are serviceable and entire pump should be replaced if found defective.

### OPERATION

**I-Mark Models** — Fuel pump will shut off immediately if the alternator belt breaks, if there is a loss of a voltage signal from the alternator or if the fusible link is open. At idle, a broken alternator belt or loss of a voltage signal will cause the engine to shut off immediately. If on fast idle or the accelerator is partly depressed, engine shut off is delayed

### REMOVAL & INSTALLATION

**I-Mark Models** — Disconnect fuel return hose from pipe and drain fuel. Remove fuel tank cover. Remove 2 screws from fuel pipe cover and remove cover. Disconnect remaining hose and wiring. Remove fuel pump attaching screws and remove fuel pump. To install, reverse removal procedure.

**Pickup Models** — Remove electrical lead and fuel lines from tank and carburetor. Remove mounting bolts and nuts and take pump off frame. To install, reverse removal procedure.

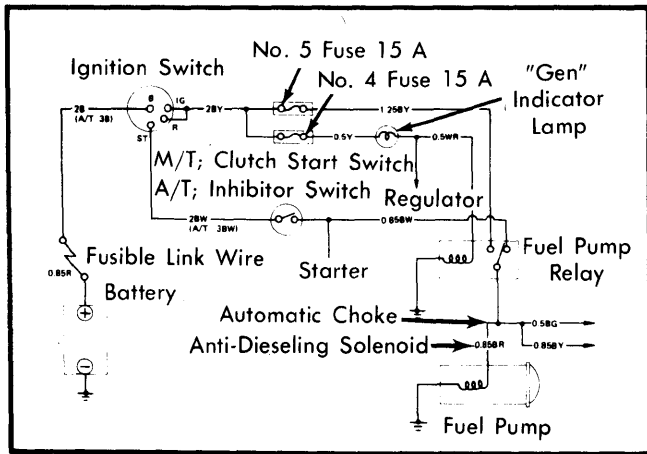

**Fig. 1 Isuzu I-Mark Fuel Pump Electrical Circuit**

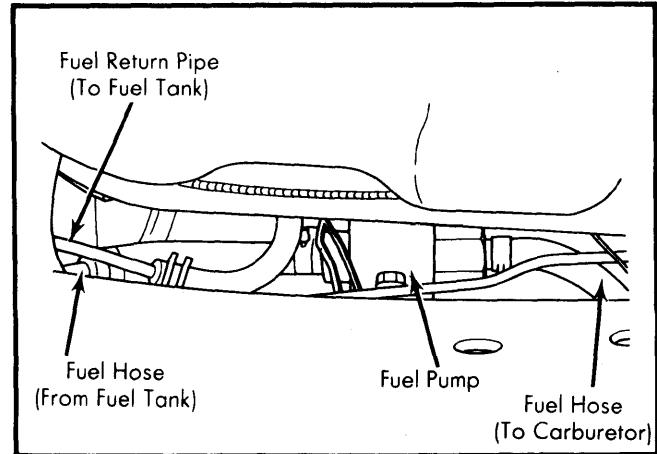

**Fig. 3 Typical Fuel Pump Installed Position (Pickup Shown — I-Mark Similar)**

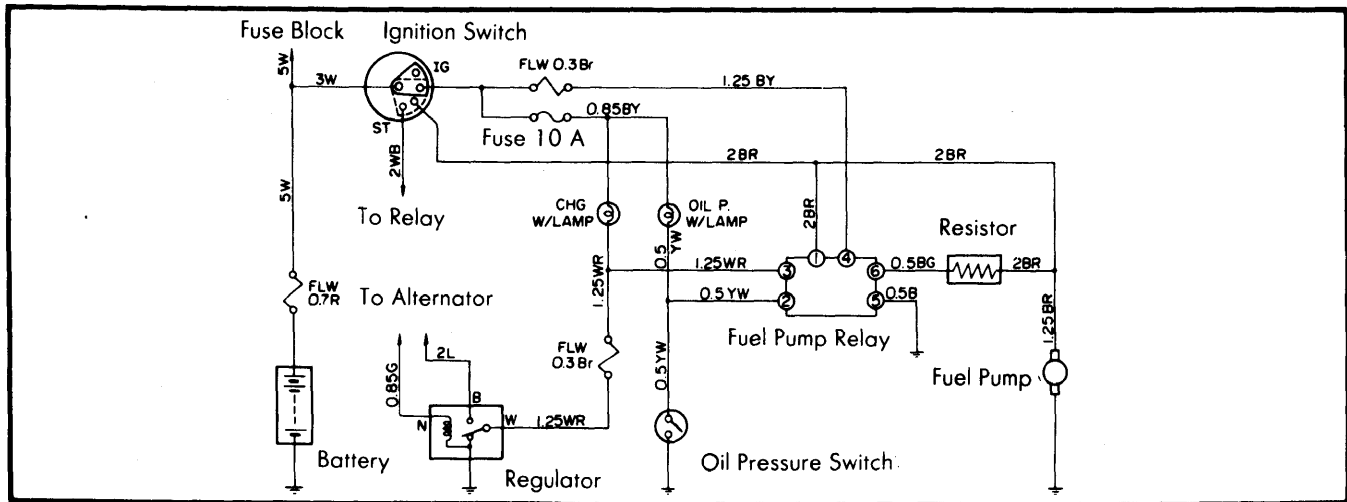

**Fig. 2 Isuzu P'UP & LUV Pickup Fuel Pump Electrical Circuit**