

COURIER & MAZDA ELECTRIC FUEL PUMPS

Courier
Pickup
Mazda
626
RX7
B2000 Pickup

DESCRIPTION

Pulsating electric powered fuel pump is mounted near fuel tank on frame member.

OPERATION & TESTING

NOTE — In line fuel filter must be changed within recommended mileage interval before performing tests. If in doubt, install new filter.

Electrical power is supplied when ignition switch is in "RUN" position. This circuit is protected by a 15 amp fuse (20 amp on RX7) at fuse panel.

Pressure Test — 1) Remove air cleaner assembly and disconnect fuel line at carburetor. Connect suitable pressure gauge with restrictor and a flexible hose as illustrated in Fig. 2.

2) Turn ignition on and briefly vent the system into container by opening hose restrictor. Pressure should stabilize within specifications. If not within specifications and lines and filter are in satisfactory condition, pump must be replaced.

Volume Test — With fuel pressure within limits, open restrictor for one minute and measure fuel expelled. If not within specifications, check for restrictions in tank, line or filter. Replace pump if required.

REMOVAL & INSTALLATION

NOTE — Negative cable should be disconnected at battery when working on fuel pump.

1) On 626 and RX7 models, open trunk lid, lift mat and disconnect fuel pump electrical lead. Raise rear of vehicle and support on stands. Remove fuel pump cover attaching bolts and cover.

2) On all models, disconnect inlet and outlet hoses and wiring connector. Remove attaching bolts and nuts and take pump off vehicle. To install, reverse removal procedure.

SPECIFICATIONS

Application	Pressure psi (kg/cm ²)	Volume oz./minute
Courier	2.8-3.6 (.20-.25)	32
626	2.8-3.6 (.20-.25)	26
RX7	3.7-4.7 (.26-.33)	37
B2000	2.8-3.6 (.20-.25)	26

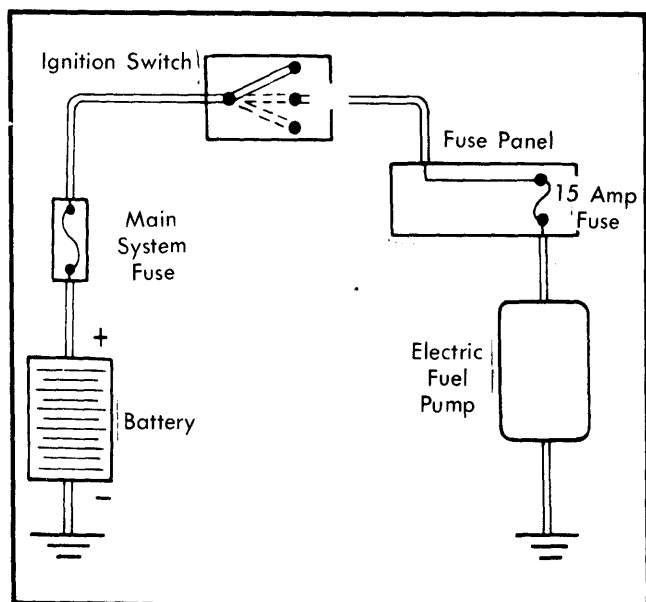

Fig. 1 Fuel Pump Circuit Schematic

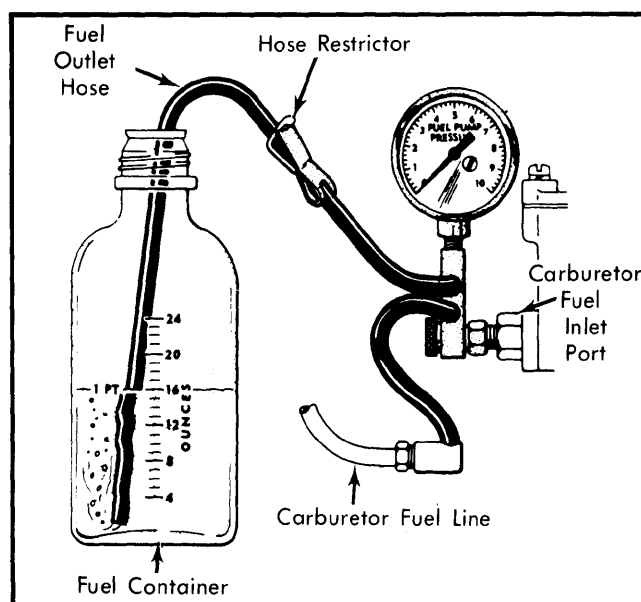

Fig. 2 Fuel Pump Pressure and Volume Test