

PORSCHE TURBOCHARGING SYSTEM

924 Turbo

DESCRIPTION

The turbocharger used on the 924 Turbo is mounted on the right side of the engine under the exhaust manifold. Components include the turbine, compressor wheel, rotor shaft, bearings and housings. See Fig. 1. A wastegate, located near the right side of the bell housing prevents excessive boost pressure. Should it fail, a boost pressure safety switch turns off the fuel pumps.

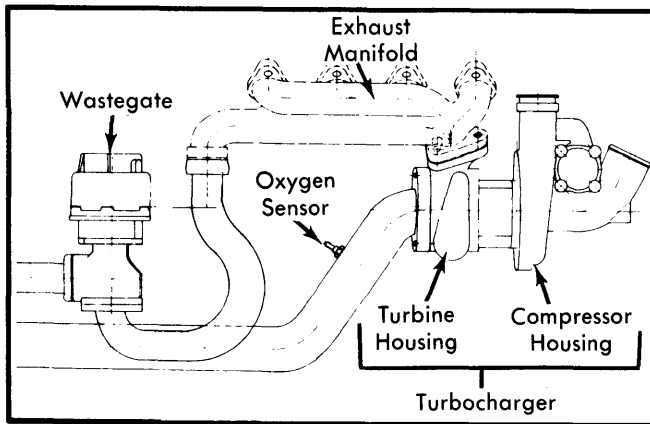

Fig. 1 Porsche Turbocharging System

OPERATION

The turbocharger is driven by exhaust gases being expelled from the cylinder combustion chambers. At idle speeds there is no pressurization of incoming air, and the engine operates like a normally aspirated engine.

At partial load, the throttle valve is open and more fuel-air mixture is drawn into the combustion chamber. Speed and volume of exhaust gases increase, in turn. The increasing volume of exhaust gases causes the turbocharger turbine to turn with greater speed. See Fig. 2. The compressor, mounted on the same shaft turns at the same speed as the turbine, producing boost pressure for incoming air. Opening the throttle valve reduces manifold vacuum, closing the pop-off valve located in the compressor housing between the inlet and outlet.

At full load, a large volume of exhaust gases are fed to the turbine, increasing speed of both the turbine and compressor wheels. When boost pressure reaches 6.2-6.8 psi (.43-.47 kg/cm²), the wastegate (boost pressure control valve) opens. Part of the exhaust gases are now routed directly into the main exhaust pipe, by-passing the turbine wheel. The turbocharger speed and boost pressure remain almost constant at 6.2-6.8 psi (.43-.47 kg/cm²).

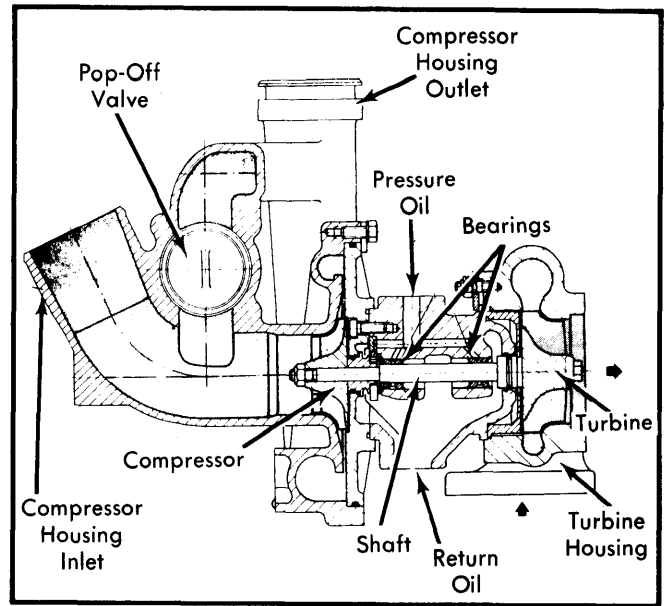

Fig. 2 Cutaway of Porsche Turbocharger

Should the wastegate fail to function properly, an electric boost pressure safety switch located in the compressor discharge pressure duct turns off the electric fuel pumps. This prevents engine damage from excessive pressures.

During deceleration, the throttle valve is closed. The turbocharger now operates against a closed throttle valve, which could damage the turbocharger. To prevent this from occurring, the pop-off valve located between the pressure and intake duct opens due to intake manifold vacuum. This sets up a bypass circuit between pressure and intake ducts. Since the wastegate valve is shut, all exhaust gases are routed to the turbocharger turbine upon acceleration.

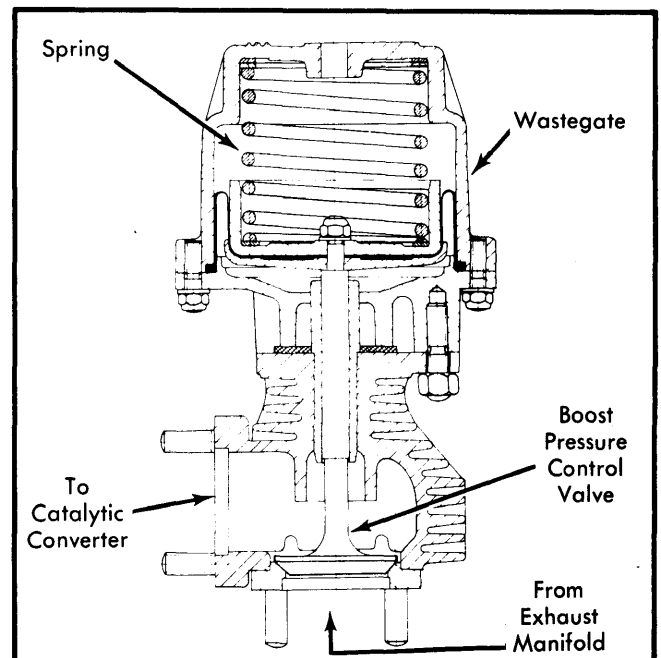

Fig. 3 Cutaway View of Porsche Wastegate

PORSCHE TURBOCHARGING SYSTEM (Cont.)

LUBRICATION

The oil filter houses a thermostat which opens at 189°F (87°C). This channels the oil either to the oil cooler or directly to the turbocharger, depending upon oil temperature. Return oil from the turbocharger flows back to the oil pan by gravity.

The oil cooler is located directly behind the air ducts in the front spoiler.

REMOVAL & INSTALLATION

TURBOCHARGER ASSEMBLY

Removal - 1) Remove engine guard and rubber cap from oxygen sensor and plug. Remove starter and disconnect and remove bypass line between exhaust manifold and wastegate.

2) Remove nuts between turbine housing and exhaust pipe. Remove bolts from flange between front and rear mufflers. Loosen muffler suspension bracket and remove rear muffler. Loosen heat shields over bypass line and loosen pipe clamp.

3) Disconnect control line at wastegate and remove entire exhaust line with wastegate. Be careful not to damage oxygen sensor.

NOTE - Some vehicles will have a vent line for the wastegate. This can only be removed after lowering exhaust line.

4) Disconnect oil lines leading to engine oil cooler and oil feed line for turbocharger. Plug oil lines at oil filter flange. Disconnect and remove oil filter flange, catching the escaping oil. Loosen oil clamps and pull out oil lines from the front.

5) Remove pressure duct and take off air cleaner upper and lower sections. Remove mounting nuts from bottom of fuel distributor. Loosen hose clamps on dust cover and move fuel distributor to one side.

6) Unscrew mounting bolt on pressure duct and take off pressure duct. Remove nuts holding exhaust manifold and turbocharger. Unscrew Allen head nuts. Loosen hose clamp. Disconnect both sides of stabilizer. Disconnect steering gear from control arm.

7) Disconnect turbocharger base and remove turbocharger with console toward front. Pull off hose from wastegate connection.

Installation - 1) Install components in reverse order of removal. Loosen Allen head bolts of the base before attempting to install turbocharger on engine. While positioning turbocharger against engine, push hose on turbocharger. Tighten mounting nuts of exhaust manifold and turbocharger and then the base.

2) Always use new seals on oil lines. Make sure that round seal fits properly on pressure duct. Install both pressure ducts before tightening bolt. Tighten steering gear bolts to 14-17 ft. lbs. (19-24 N·m).

3) Before starting engine for first time, prime turbocharger with lubricating oil for 15 seconds by pulling plugs off manifold pressure limiting switch and operating starter.