

## DATSUN TURBOCHARGING SYSTEM

## 280ZX

## DESCRIPTION

The Datsun 280ZX turbocharger is mounted on the exhaust manifold on the left side of the engine. Components of the turbocharger include turbine and compressor impellers (wheels), impeller shaft, bearings, impeller housings, wastegate controller, and wastegate (exhaust bypass valve). See Fig. 1.

The pressure actuated wastegate, located at the front of the compressor housing, prevents excessive intake boost pressure. If it fails, an emergency relief valve located on the intake manifold releases any excess pressure. Engine oil pressure provides constant lubrication to the impeller bearings.

## OPERATION

The turbine impeller of the turbocharger is driven by the exhaust gases expelled from the cylinder combustion chambers. At idle speeds there is no pressurization of intake air and the engine operates like a normally aspirated engine.

With engine under partial load, the throttle valve opens and more fuel-air mixture is drawn into the combustion chambers. The speed and volume of exhaust gases also increases. The increased amount of exhaust gases turns the turbine impeller at a faster RPM. The compressor impeller turns at the same RPM as the turbine impeller because they are mounted on the same shaft. The increased RPM of the compressor impeller boosts the pressure of the intake air.

With engine under full load, the exhaust gases are at maximum pressure and increase the RPM of the turbine and compressor impellers to an extremely high speed. The boost pressure of the intake air reaches a maximum. When the pressure in the intake manifold reaches 6.08-6.85 psi (.43-.48 kg/cm<sup>2</sup>), the diaphragm of the wastegate controller pushes against the linkage which opens the wastegate. Part of the exhaust gases are then routed directly into the main exhaust pipe, bypassing the turbine impeller. This maintains the boost pressure of the intake air at a constant 6.19-7.35 psi (.44-.52 kg/cm<sup>2</sup>).

If the wastegate fails to function properly, an emergency relief valve located on the intake manifold opens to atmosphere when the intake manifold pressure reaches 7.35-7.73 psi (.52-.54 kg/cm<sup>2</sup>). This prevents engine damage from excessive pressure.

## TESTING

**NOTE** — If any turbocharger parts fail inspection or testing, replace entire turbocharger assembly.

## TURBINE AND COMPRESSOR IMPELLERS

1) Inspect turbine and compressor impellers for cracks, clogging, deformity, or damage. Rotate impellers to be sure that they turn freely without any abnormal noise.

**NOTE** — Do not rotate impellers while measuring end play of shaft.

2) Connect a dial indicator to end of impeller shaft and measure end play of shaft. Indicator should read 0.0005-0.0036" (0.013-0.091 mm). See Fig. 2.

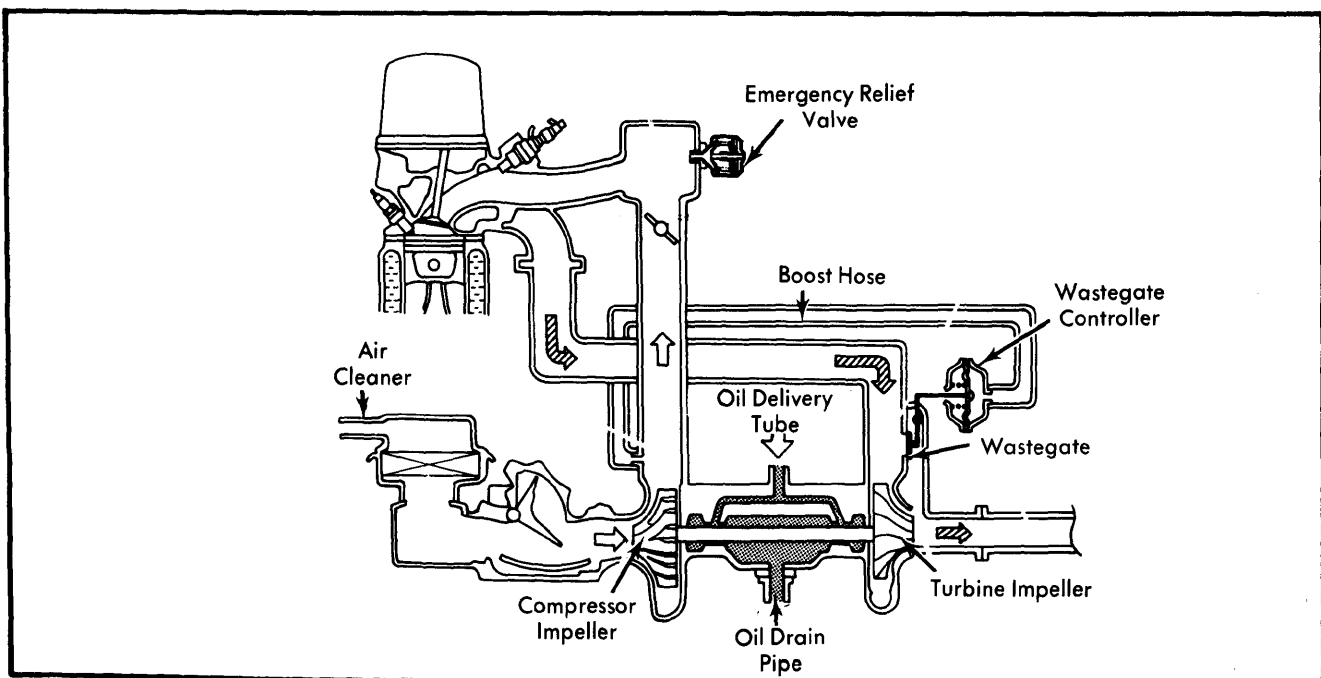
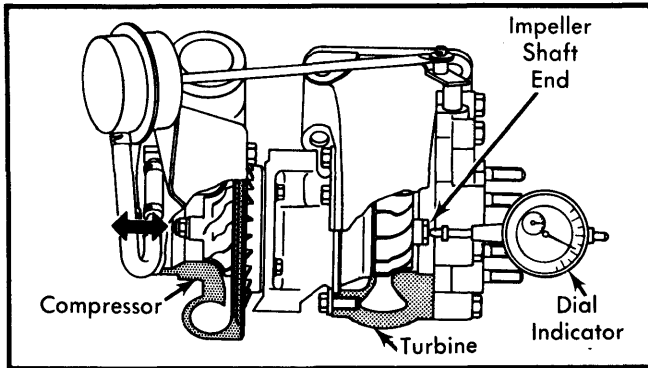

Fig. 1 Cutaway of Datsun Turbocharger

## DATSUN TURBOCHARGING SYSTEM (Cont.)



**Fig. 2 Measuring Impeller Shaft End Play**

### WASTEGATE CONTROLLER

**CAUTION** — Do not apply more than 9.67 psi (.68 kg/cm<sup>2</sup>) to wastegate controller diaphragm.

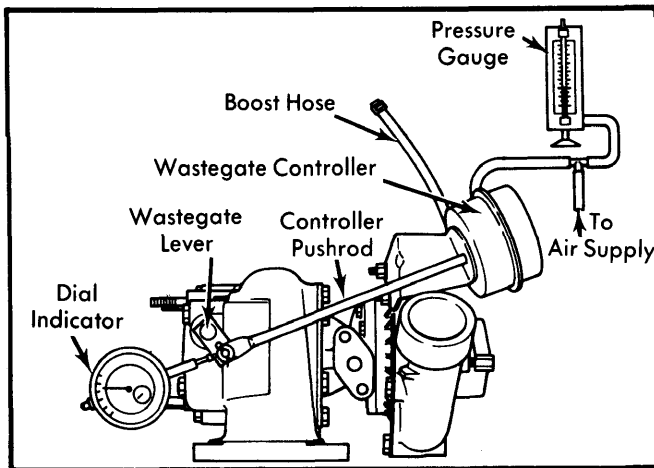

**Fig. 3 Testing Wastegate Controller**

1) Connect a dial indicator to end of wastegate controller pushrod. See Fig. 3. Disconnect boost hose at wastegate controller. Connect a pressure gauge to wastegate controller and apply 6.08-6.85 psi (.43-.48 kg/cm<sup>2</sup>). Wastegate controller pushrod should move 0.015" (0.38 mm).

2) Disconnect wastegate controller pushrod. Move wastegate lever back and forth and check for binding or sticking.

### REMOVAL & INSTALLATION

#### TURBOCHARGER ASSEMBLY

**Removal** — 1) Remove heat insulator, inlet tube, air duct hose, and suction air pipe.

2) Disconnect exhaust gas sensor connector, front tube, oil delivery tube, and oil drain pipe. See Fig. 4.

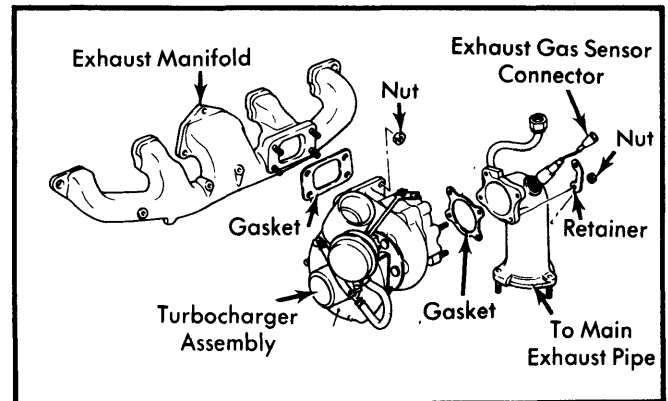

**Fig. 4 Datsun Turbocharger Removal**

3) Remove 4 nuts securing turbocharger to exhaust manifold. Remove turbocharger and gasket.

**Installation** — Install components in reverse order of removal. Replace gasket between turbocharger and exhaust manifold.