

NIKKI 2-BARREL - MAZDA 626

Mazda 626

DESCRIPTION

Carburetor is a 2-barrel downdraft type. It is equipped with an electric automatic choke, an air by-pass valve for deceleration control, an idle compensator, high altitude compensator, air vent solenoid, slow fuel cut solenoid and throttle positioner system for air conditioned models. A double venturi provides for high air flow velocity at the venturi under all operating conditions, resulting in more efficient atomization of fuel for smooth combustion.

ADJUSTMENTS

HOT (SLOW) IDLE RPM

See appropriate *TUNE-UP SERVICE PROCEDURES* article.

IDLE MIXTURE

See appropriate *TUNE-UP SERVICE PROCEDURES* article.

COLD (FAST) IDLE RPM

See appropriate *TUNE-UP SERVICE PROCEDURES* article.

AUTOMATIC CHOKE SETTING

Before starting engine, fully depress accelerator pedal to ensure choke valve closes properly. Push choke valve with finger to check for binding. Be sure thermostat cover index mark is set at second choke housing index mark. See Fig. 1. Warm engine and check that choke valve is fully open. Tighten all attaching screws after aligning index mark.

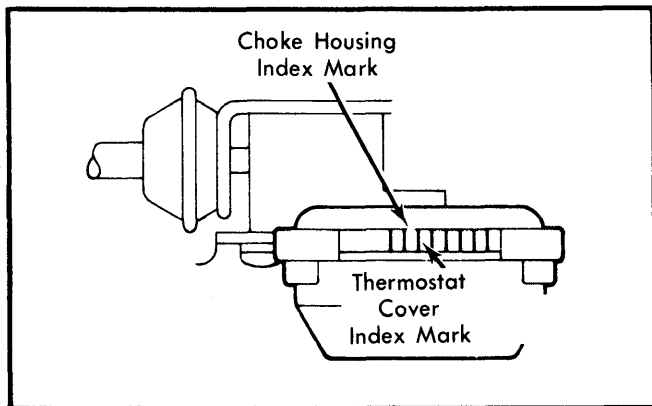

Fig. 1 Adjusting Automatic Choke

FLOAT LEVEL ADJUSTMENT

Remove air horn from carburetor. Remove air horn gasket. Invert air horn on stand and allow float to lower by its own weight. Bend float seat lip until clearance between float and air horn bowl is .452" (11.5 mm). See Fig. 2.

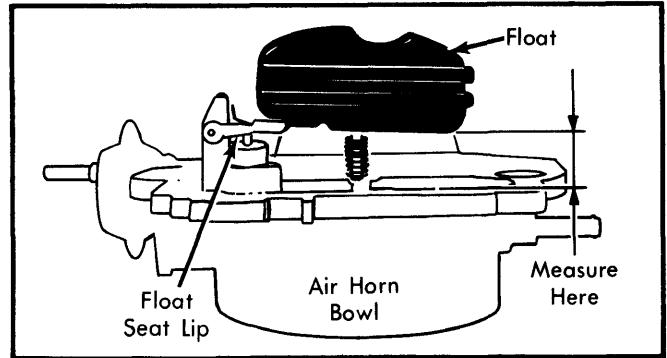

Fig. 2 Adjusting Float Level

FLOAT DROP ADJUSTMENT

Adjust float level and turn air horn over to its normal position. Make adjustment without gasket on air horn. Allow float to lower by its own weight. See Fig. 3. Measure distance between bottom of float and air horn bowl. If clearance is not 1.811" (46 mm), bend float stopper to obtain proper clearance.

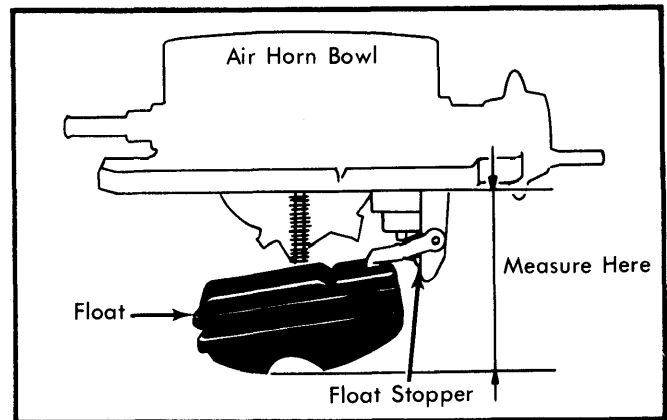

Fig. 3 Adjusting Float Drop

CHOKE LINKAGE ADJUSTMENT (FAST IDLE OPENING ANGLE)

Fully close choke valve. Position fast idle lever on second step of fast idle cam. Set clearance between throttle valve and throttle bore to .018-.030" (.45-.75 mm) by turning fast idle adjusting screw. Turning screw clockwise increases angle size. See Fig. 4.

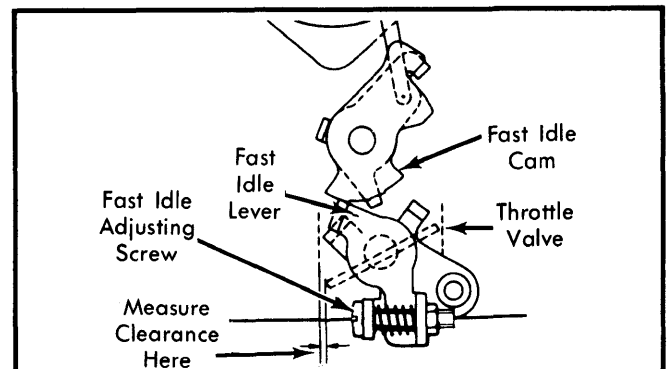

Fig. 4 Choke Linkage Adjustment (Fast Idle Opening Angle)

NIKKI 2-BARREL – MAZDA 626 (Cont.)

CHOKE VALVE OPENING ANGLE

Check choke linkage adjustment, then place fast idle lever on second step of fast idle cam. Measure clearance between choke valve and carburetor bore. Choke valve clearance should be .026-.041" (.65-1.05 mm). Adjust clearance by bending starting arm. If large adjustment is necessary, bend choke rod. See Fig. 5.

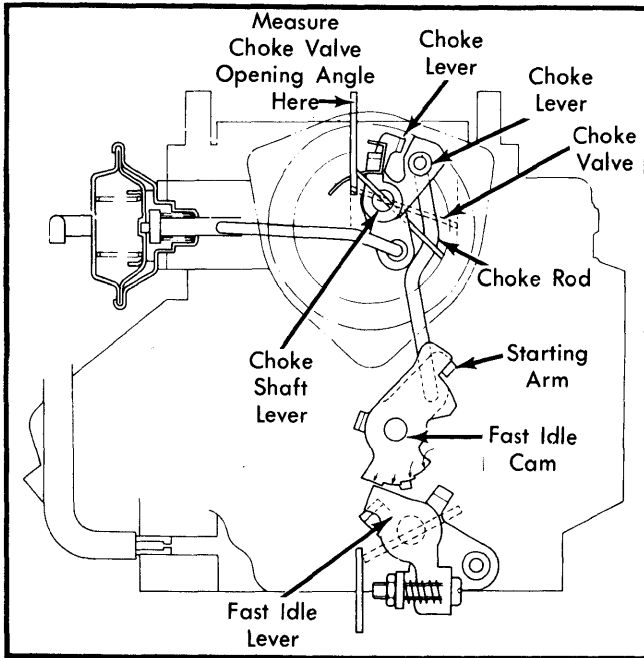

Fig. 5 Adjusting Choke Valve Opening Angle

CHOKE DIAPHRAGM ADJUSTMENT

Apply approximately 15.7 in. Hg vacuum to choke diaphragm vacuum tube. Fast idle lever should be on high step of cam. Press choke valve slightly and check choke valve opening clearance. Bend choke lever until clearance is .057-.077" (1.45-1.95 mm). See Fig. 6.

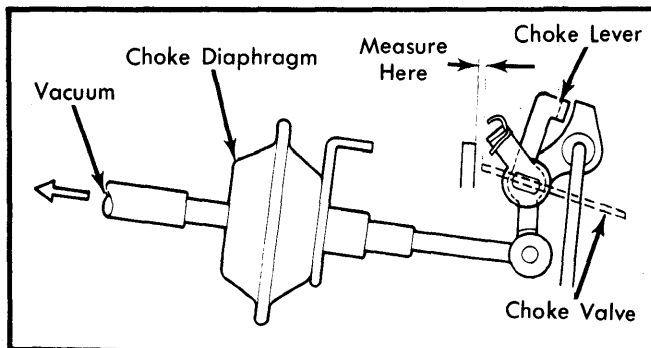

Fig. 6 Adjusting Choke Diaphragm

CHOKE UNLOADER ADJUSTMENT

Fully close choke valve and then open primary throttle valve. Measure choke valve clearance. Adjust clearance to .104-.136" (2.65-3.45 mm) by bending tab. See Fig. 7.

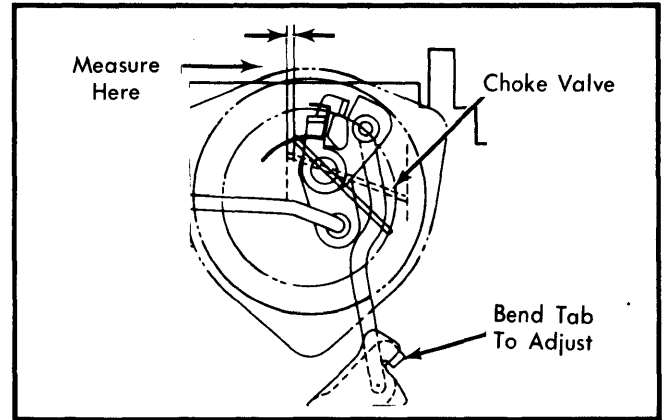

Fig. 7 Adjusting Choke Unloader

SECONDARY THROTTLE VALVE OPENING ANGLE

The secondary valve should begin to open when primary throttle valve opens 50° and should be fully open when primary valve is fully open. Check clearance of primary throttle valve and wall of throttle bore as secondary throttle valve begins to open. Bend throttle arm until clearance is .244-.283" (6.2-7.2 mm). See Fig. 8.

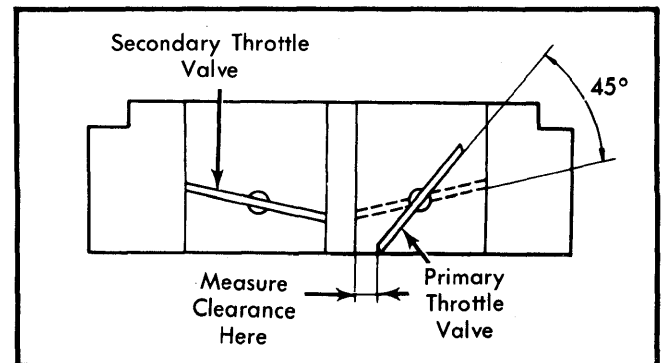

Fig. 8 Adjusting Secondary Throttle Valve Opening Clearance

ACCELERATOR PEDAL HEIGHT ADJUSTMENT

Accelerator pedal should be 1.5-1.9" (40-50 mm) lower than brake pedal. Cable free play at carburetor should be .04-.12" (1-3 mm). If free play is not to specifications, adjust nut "A" on cylinder head cover. As final check, depress pedal to the floor and check that throttle valves are wide open. If necessary, adjust stopper bolt. See Fig. 9.

NIKKI 2-BARREL – MAZDA 626 (Cont.)

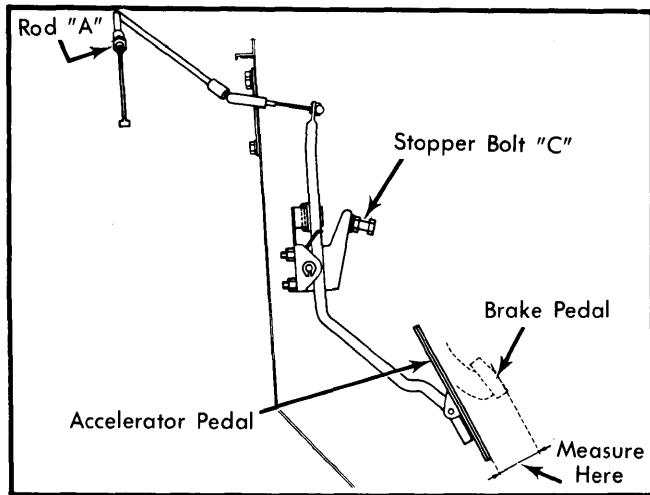

Fig. 9 Adjusting Accelerator Pedal Height

THROTTLE OPENER ADJUSTMENT

1) Connect tachometer to engine. Warm engine to normal operating temperature and set idle at specified idle RPM. Stop engine and remove air cleaner. Disconnect 3-way solenoid valve-to-servo diaphragm vacuum sensing tube from servo diaphragm.

2) Connect inlet manifold vacuum directly to servo diaphragm. Start engine and increase engine speed to 2000 RPM. Turn air conditioner on. Decrease engine speed and make sure speed remains at 1100-1300 RPM by turning adjusting screw.

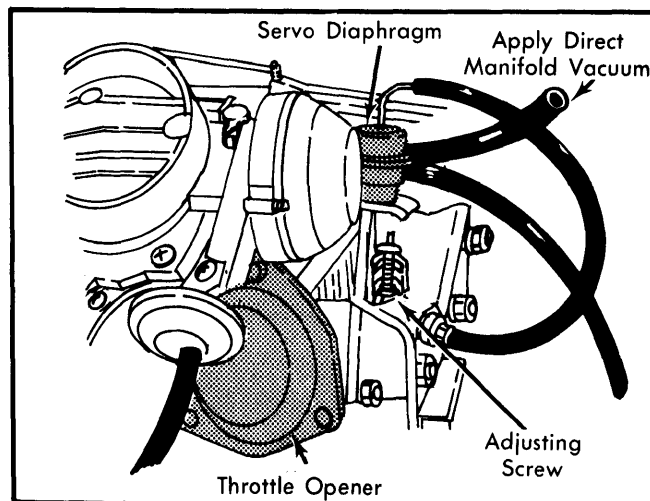

Fig. 10 Adjusting Throttle Opener (A/C Models Only)

OVERHAUL

DISASSEMBLY

1) Remove carburetor and cover intake manifold with clean shop towel. Begin disassembly with air horn and automatic choke. Remove vacuum tube, accelerating pump connecting

rod and lever. Remove connecting spring. Spread clip that retains choke heater lead and slow fuel cut solenoid valve-lead and remove leads.

2) Disconnect choke rod. Remove fuel inlet fitting, filter and packing. Remove air vent solenoid valve. Separate air horn and automatic choke assembly from main body. Remove choke cover attaching screws and choke cover.

3) Disconnect choke diaphragm rod from choke lever. Mark position of choke housing index mark and thermostat cover index mark. Remove choke heater screws, choke heater, choke diaphragm and bracket. From the air horn, remove float pin, float, gasket and needle valve assembly.

4) From main body, remove accelerating pump plunger assembly and inlet check ball retaining clip. Invert main body and remove inlet strainer and accelerating pump inlet check ball, check valve plug and washer. Remove accelerating pump outlet check ball and spring.

5) Turn main body upright and remove slow fuel cut solenoid valve and gasket. Disconnect throttle linkage and vacuum diaphragm connecting rod. Remove main body attaching bolts and remove main body from throttle body. Remove diaphragm assembly retaining screws and gasket.

NOTE — One bolt attaching main body is inside the throttle body.

6) Remove diaphragm cover screws and cover. Remove spring, diaphragm and throttle lever hanger retaining screw from diaphragm. Remove fuel blow sight glass retaining screws, then remove cover, gasket, glass and rubber gasket. Remove all air bleeds and jets from main body. Note size of all jets and bleeds for reinstallation in original position. See Fig. 11.

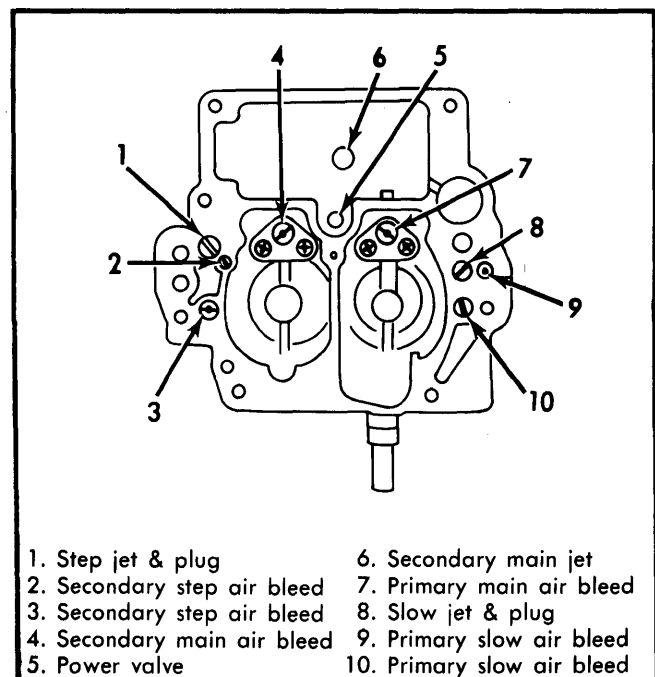

Fig. 11 Removing Air Bleeds and Jets

NIKKI 2-BARREL – MAZDA 626 (Cont.)

7) Remove throttle hanger and other levers, but do not remove throttle valve and shaft, venturi or choke valve and shaft from throttle body. See Fig. 12. Using a hacksaw, cut through mixture screw shell $\frac{1}{2}$ " (12 mm) from shell end. Remove and discard mixture screw, spring and shell.

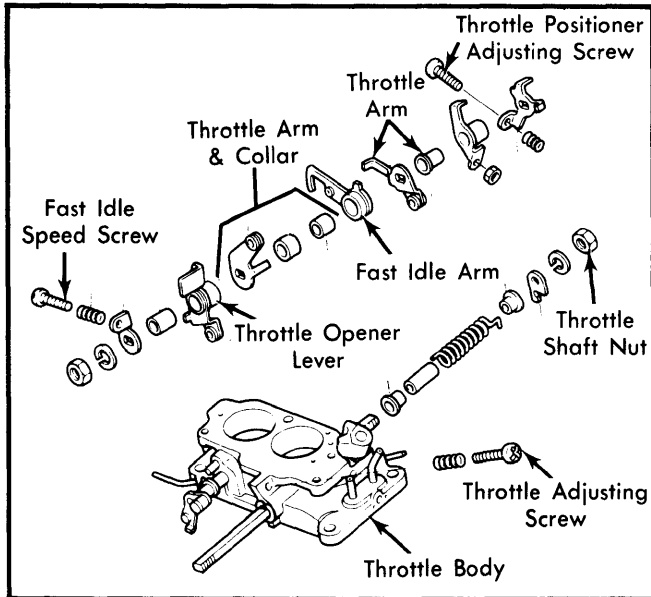

Fig. 12 Removing Throttle Body Parts

INSPECTION

1) Wash all parts in clean gasoline and blow out fuel passages with compressed air. Never use wire for cleaning jets. Inspect air horn, main body and throttle body for cracks and breakage.

2) Check float needle and seat for wear and float for damage. Inspect choke shaft and throttle shaft for wear. Examine all jets and air bleeds for clogs. Inspect accelerator pump plunger for wear or damage. Check diaphragms and inspect mixture adjusting screws.

3) Test solenoid valve operation by grounding body while terminal is touched to battery positive post. Valve stem should pull into solenoid body.

REASSEMBLY

To assemble, reverse disassembly procedure. Be careful not to mistake primary and secondary parts. When installing thermostat cover on automatic choke housing, hook choke arm to bi-metal spring. Check correct operating of choke valve by turning thermostat cover. Then align index marks. Install new mixture screw and limiter shell.

CARBURETOR ADJUSTMENT SPECIFICATIONS							
Application	Idle Speed (Engine RPM)		Float Level Setting In. (mm)	Float Drop Setting In. (mm)	Choke Linkage (Off Car) In. (mm)	Accelerator Cable Free Play	Choke Valve Opening In. (mm)
	Hot	Fast					
626	ⓐ650	3000-4000	.452 (11.5)	1.811 (46)	.018-.030 (.45-.75)	.04-.12 (1-3)	.026-.041 (.65-1.05)

ⓐ — Auto. Trans. in "D" range.