

HITACHI 4-BARREL

Mazda RX7

DESCRIPTION

Carburetor is of 4-barrel, 2-stage design. Primary stage includes idle system, slow speed circuit, accelerator pump system and main metering system. In addition, Federal models are equipped with a sub-zero starting device which admits fluid into the primary stage. Secondary stage contains secondary vacuum diaphragm operating system, stepping circuit and main metering system. Choking is accomplished through a semi-automatic choke. Other features include a deceleration control system, automatic choke return, hot start assist, idle compensation and dashpot (manual transmission).

ADJUSTMENTS

HOT (SLOW) IDLE RPM

See appropriate *TUNE-UP SERVICE PROCEDURES* article.

IDLE MIXTURE

See appropriate *TUNE-UP SERVICE PROCEDURES* article.

COLD (FAST) IDLE RPM

See appropriate *TUNE-UP SERVICE PROCEDURES* article.

FLOAT LEVEL ADJUSTMENT

Before assembling air horn to main body, adjust float level. Invert air horn on stand and allow float to drop by its own weight. Measure clearance between float and air horn gasket. See Fig. 1. Clearance should be .61-.65" (15.5-16.5 mm). If not within specifications, bend float seat lip as necessary.

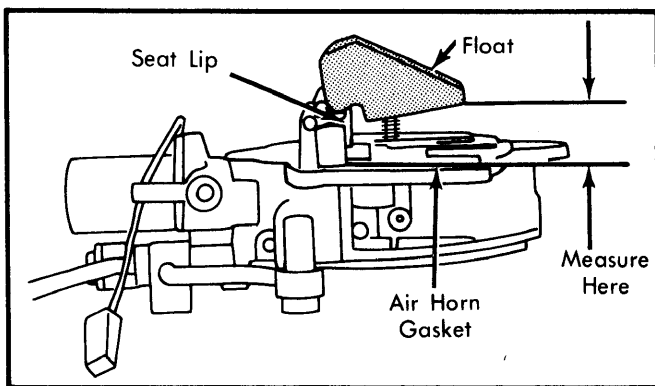

Fig. 1 Adjusting Float Level

FLOAT DROP ADJUSTMENT

Turn air horn over to its normal position and allow float to lower by its own weight. Measure distance between bottom of float and air horn gasket. See Fig. 2. Distance should be 1.98-2.03" (50.5-51.5 mm). If not, bend float stopper to obtain proper distance.

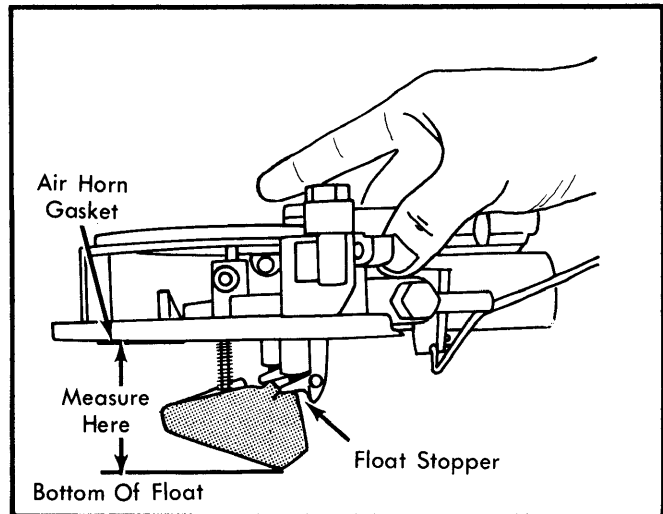

Fig. 2 Adjusting Float Drop

CHOKE LINKAGE ADJUSTMENT
(FAST IDLE OPENING ANGLE)

Close choke valve fully and measure clearance between primary throttle valve and wall of throttle bore. Set clearance to .03-.04" (0.8-1.0 mm) by bending fast idle rod. See Fig. 3.

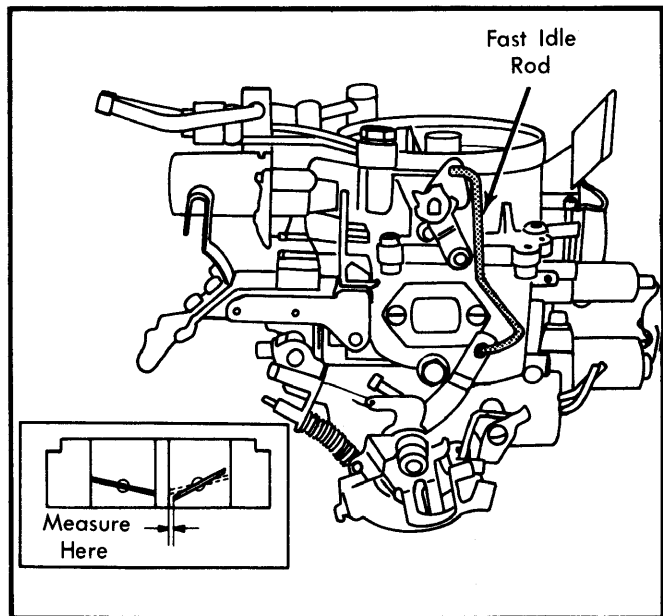

Fig. 3 Adjusting Choke Linkage
Fast Idle Opening Angle

CHOKE VALVE OPENING
ANGLE ADJUSTMENT

Disconnect vacuum sensing tubes from No. 1 vacuum diaphragm. Pull choke lever link out fully and hold in place. Apply more than 19.7 in. Hg to upper vacuum sensing tube. See Fig. 4. With vacuum applied, clearance "A" shown in Fig. 4 should be .22-.24" (5.5-6.2 mm). Apply more than 19.7 in Hg to both vacuum hoses and measure clearance again. With vacuum applied to both hoses, clearance "A" should be .45-.51" (11.5-13.0 mm).

HITACHI 4-BARREL (Cont.)

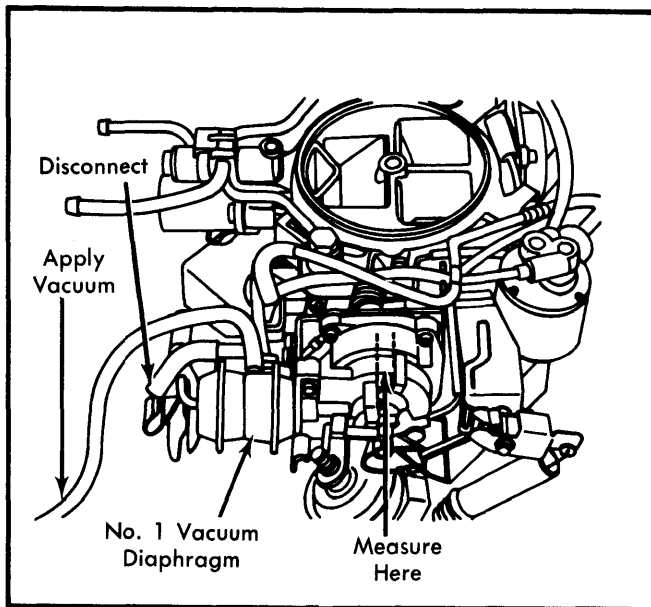

Fig. 4 Adjusting Choke Valve Opening Angle

NO. 2 CHOKE DIAPHRAGM

Disconnect vacuum sensing tubes from No. 2 vacuum diaphragm. Pull choke lever link out fully and hold in place. Choke valve should close fully. (Cool bi-metal coil if necessary). Apply more than 19.7 in. Hg to vacuum diaphragm and measure clearance between choke plate and bore. Clearance should be .057-.070" (1.46-1.80 mm).

CHECKING CHOKE DIAPHRAGM OPERATION (NO. 1 & NO. 2 DIAPHRAGMS)

Remove air cleaner. Start engine and run at idle. Disconnect vacuum sensing tubes from both diaphragms. Each diaphragm shaft should move outward from diaphragm.

CHECKING CHOKE DELAY VALVE OPERATION

Warm engine to normal operating temperature. Stop engine and remove assembly. Disconnect vacuum sensing tube from No. 1 choke diaphragm. Start engine and run at idle speed. Diaphragm shaft should move fully inward within 10-20 seconds after reconnecting vacuum sensing tube to choke diaphragm.

NOTE — Automatic transmission must be in Neutral.

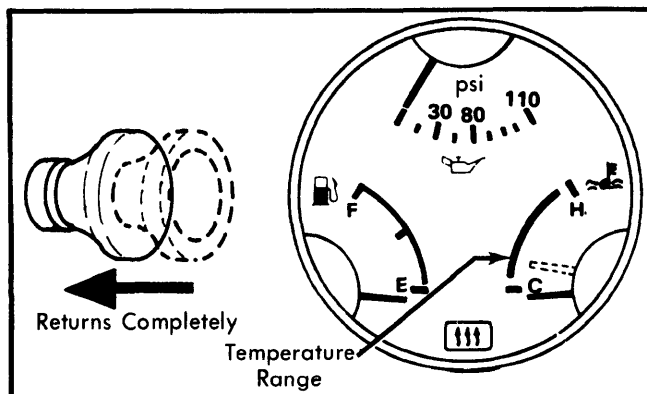

Fig. 5 Checking Automatic Choke Release

CHECKING AUTOMATIC CHOKE RELEASE

With engine cold and ignition off, pull choke knob out fully and release. Knob should return automatically and freely. Connect tachometer to engine. Start engine and set engine speed at 2000 RPM with choke knob. As engine temperature reaches range indicated in Fig. 5, choke knob should return automatically and freely.

CHECKING CARBURETOR HEATER

1) Disconnect electrical connector from No. 1 water temperature switch and connect jumper wire to both terminals of connector. Connect tachometer to engine. Disconnect carburetor heater electrical connector and connect voltmeter to connector. Start engine and set engine speed at 2000 RPM with choke knob.

2) With choke knob pulled out, current should flow to carburetor heater lead. Current should not flow to heater lead with choke knob pushed in.

3) Connect ohmmeter between carburetor heater lead and carburetor body. If ohmmeter shows no movement, carburetor heater is defective and must be replaced.

HOT START ASSIST CABLE ADJUSTMENT

Remove lock spring of hot start assist cable from cable bracket. Slowly pull outer cable until hot start lever just touches stopper lever. Check clearance between cable bracket and lock nut on cable. See Fig. 6. Clearance should be .02-.08" (0.5-2.0 mm). If not within specifications, adjust by turning lock nut. Then install lock spring securely on cable.

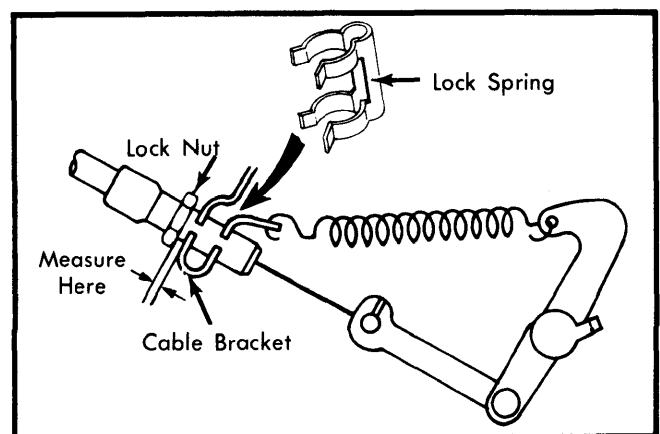

Fig. 6 Adjusting Hot Start Assist Cable

THROTTLE OPENER ADJUSTMENT (A/C MODELS ONLY)

1) Turn off all accessories. Remove fuel filler cap. Disconnect and plug idle compensator tube at air cleaner. Connect tachometer to engine and warm engine to normal operating temperature. Disconnect electrical connector from air switching solenoid valve (Gray color dot). Disconnect and plug vacuum sensing tubes at distributor vacuum control units.

HITACHI 4-BARREL (Cont.)

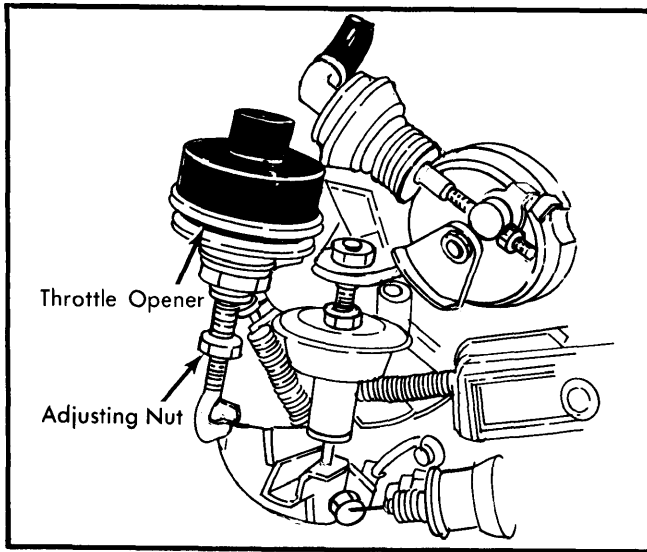

Fig. 7 Adjusting Throttle Opener (A/C Models Only)

2) Turn off air conditioner switch. Disconnect electrical connector from air conditioner solenoid (except Calif. Man. Trans.). Connect battery power to one terminal in connector and ground the other terminal. Throttle opener should operate and engine speed should increase to 1150-1250 RPM in neutral. If engine speed is not to specification, turn adjusting nut shown in Fig. 7.

CHECKING ALTITUDE COMPENSATOR

NOTE — Altitude compensator must be checked at altitudes of 1640-4920 feet.

Remove air cleaner and start engine. Engine should run smoothly at specified idle. Place finger over slow port on carburetor air horn; idle speed should drop (altitude of 1640-4920 feet). If idle speed did not drop, remove compensator valve and blow through both ports. At altitude of 1640-4920 feet, air should pass through compensator valve. If not replace altitude compensator valve.

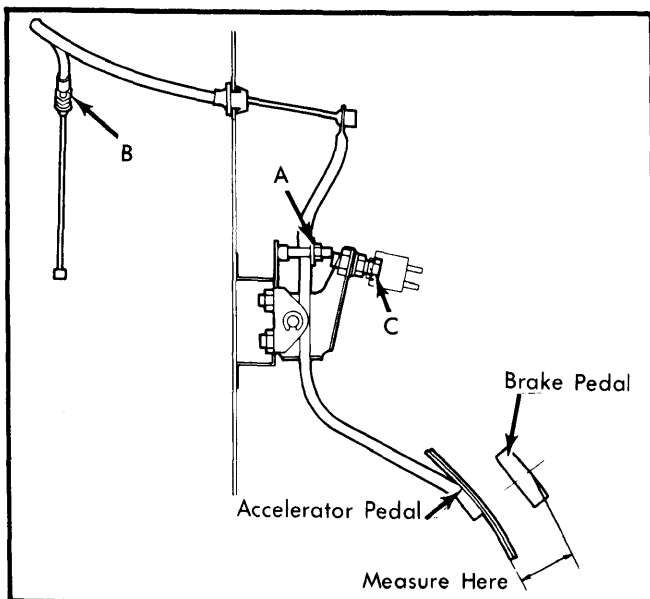

Fig. 8 Adjusting Accelerator Cable and Pedal Height

ACCELERATOR CABLE ADJUSTMENT

Check accelerator pedal position. Pedal should be 1.5-1.9" (37-47 mm) lower than brake pedal. See Fig. 8. If necessary, adjust nut "A" to obtain correct position. Cable free play at carburetor should be .04-.12" (1-3 mm). To adjust free play, adjust nut "B". Depress accelerator all the way to floor and check that throttle valves are wide open. If necessary, adjust stopper bolt "C".

OVERHAUL

NOTE — Disassembly and assembly procedures will vary somewhat from vehicle to vehicle, depending upon sales area (Federal or California) and type of transmission. Therefore, some carburetors may not have all parts referred to in the following procedures.

DISASSEMBLY

1) Remove carburetor from vehicle and begin disassembly with semi-automatic choke housing and air horn. Remove vacuum sensing tubes for altitude compensator valve and choke delay valve. Remove choke heater lead. Remove choke diaphragm No. 2 vacuum sensing tube. Remove altitude compensator valve.

2) Remove throttle opener and bracket assembly. Remove No. 1 choke diaphragm vacuum sensing tube. Remove dashpot diaphragm and bracket assembly (Man. Trans. only). Remove throttle return spring, sub-return spring, return spring bracket, bi-metal spring housing and bracket assembly and No. 1 choke diaphragm.

3) Remove split pin and fast idle rod, hot start assist lever spring and bracket assembly, choke lever, choke return diaphragm and bracket. Remove No. 2 choke diaphragm. Remove air horn attaching screws and remove air horn assembly from main body. Disconnect float pin and remove float, needle valve, spring, valve stem and retainer.

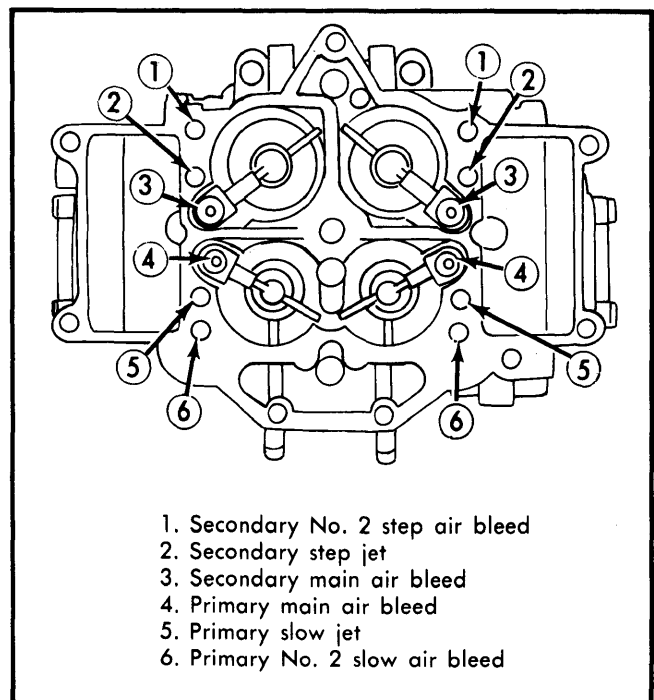

Fig. 9 Removing Jets and Air Bleeds

HITACHI 4-BARREL (Cont.)

4) From main body, remove accelerator pump rod, secondary throttle valve rod, throttle sensor and main body attaching bolts. Remove main body from throttle body. Remove secondary throttle attaching screws, cover, return spring, pin and clip, diaphragm, housing and gasket.

5) Remove "E" clip, washer and shaft, accelerator pump lever, attaching screws, cover, diaphragm and return spring. From main body, remove accelerator pump injection screw, nozzle, gasket, weight, outlet check valve, check valve seat, weight and inlet check valve. Remove retainer, blind plug and washer, primary main jet and secondary main jet.

6) Remove air bleeds and jets. See Fig. 9. Using a hacksaw, remove idle limiter cap by cutting through limiter cap and mixture adjusting screw 0.4" (10 mm) from cap end. Remove and discard mixture adjusting screw and spring.

INSPECTION

Wash all parts in clean solvent, blow fuel passages with compressed air and remove dirt. Never use wire for cleaning jets. Inspect air horn, main body and throttle body for cracks or breakage. Inspect choke shaft and throttle shaft for wear, linkage and connecting rods for bends, and return springs for damage. Inspect float, needle valve and seat and strainer for damage. Check air vent solenoid valve for proper operation.

REASSEMBLY

To assemble, reverse disassembly procedure. Discard all old gaskets, using new ones. Clean and inspect all parts. Prevent primary and secondary system parts from becoming mixed. When installing bi-metal spring housing, fit choke shaft lever to bi-metal spring by closing choke valve and pulling vacuum diaphragm shaft.

CARBURETOR ADJUSTMENT SPECIFICATIONS							
Application	Idle Speed (Engine RPM)		Float Level Setting In. (mm)	Float Drop Setting In. (mm)	Choke Linkage (Off Car) In. (mm)	Accelerator Cable Free Play	Choke Valve Opening In. (mm)
	Hot	Fast					
RX7	750	⓪	.61-.65 (15.5-16.5)	1.8-2.2 (46-56)	.22-.24 (5.5-6.2)	.04-.12 (1-3)	.03-.04 (0.8-1.0)

⓪ - Manufacturer does not supply fast idle speed. See Choke Linkage (Fast Idle Opening Angle).