

## HITACHI DCH 340 &amp; DCR 342 2-BARREL

Datsun 510  
Datsun Pickup  
LUV Pickup

Isuzu I-Mark  
Isuzu P'UP

float bowl. Set clearance to .283" (7.2 mm) by bending float tang. See Fig. 1.

## DESCRIPTION

Carburetor is a 2-barrel downdraft type with piston type accelerator pump. Carburetor consists of low speed (primary) barrel and high speed (secondary) barrel integrated into a single unit with a common fuel bowl. Secondary throttle is actuated by a vacuum diaphragm when primary throttle is open a predetermined amount. Additional equipment includes an anti-dieseling solenoid, electric choke, coasting riching solenoid (Isuzu and LUV), idle compensator (Datsun), a dashpot (Datsun with Auto. Trans.), and an altitude compensator (Calif. Datsun).

## CARBURETOR IDENTIFICATION

Carburetor No.

Application	Man. Trans.	Auto. Trans.
Datsun 510		
Federal .....	DCR342-4 .....	DCR342-6
	DCR342-5①	
Calif. ....	DCR342-1 .....	DCR342-3
	DCR342-2①	
Datsun Pickup		
Federal		
Standard .....	DCR342-14 .....	DCR342-16
	DCR342-15①	
Heavy Duty .....	DCR342-23 .....	
	DCR342-24①	
Calif.		
Standard .....	DCR342-11 .....	DCR342-13
	DCR342-12①	
Heavy Duty .....	DCR342-21 .....	
	DCR342-22①	
4WD .....	DCR342-17 .....	
	DCR342-18①	
Isuzu & LUV		
I-Mark .....	DCH340-251 .....	DCH340-252
P'UP & LUV		
Federal .....	DCH340-211 .....	DCH340-212
Calif. ....	DCH340-213 .....	DCH340-214

① — With air conditioning.

## ADJUSTMENTS

## HOT (SLOW) IDLE RPM

See appropriate TUNE-UP SERVICE PROCEDURES article.

## IDLE MIXTURE

See appropriate TUNE-UP SERVICE PROCEDURES article.

## COLD (FAST) IDLE RPM

See appropriate TUNE-UP SERVICE PROCEDURES article.

## FLOAT LEVEL

**NOTE** — Fuel bowl is equipped with a sight glass. Line on sight glass indicates proper fuel level. If adjustment must be made to correct improper level, use following procedure.

**Datsun** — With sight glass removed and carburetor main body inverted, measure distance from top of float to top of

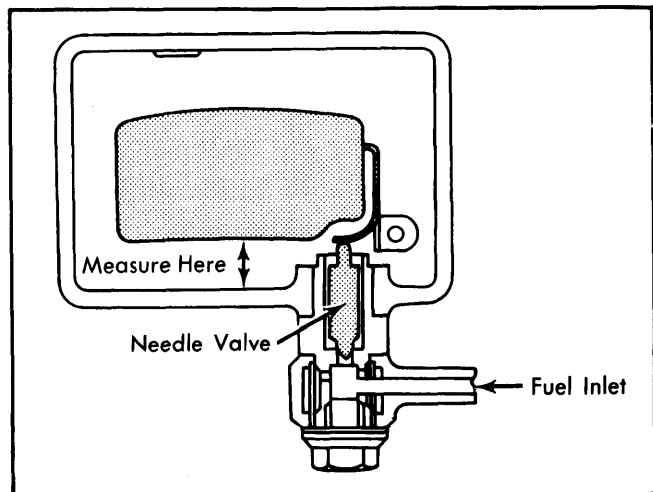

Fig. 1 Float Level Measurement Point

**Isuzu & LUV** — With sight glass removed and carburetor main body inverted, bend float tang until float is parallel with top of float bowl.

## FLOAT DROP

With float bowl removed and held upright, measure clearance between needle valve and float tang. If clearance is not .059" (1.5 mm), adjustment will be necessary. Adjust by bending float tang which contacts needle valve. See Fig. 2.

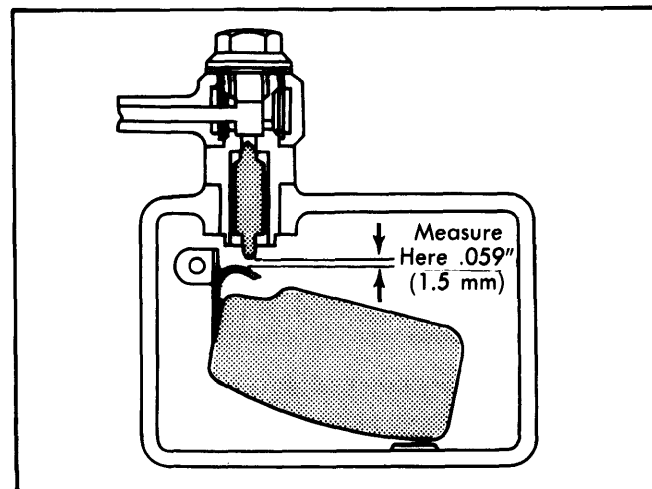
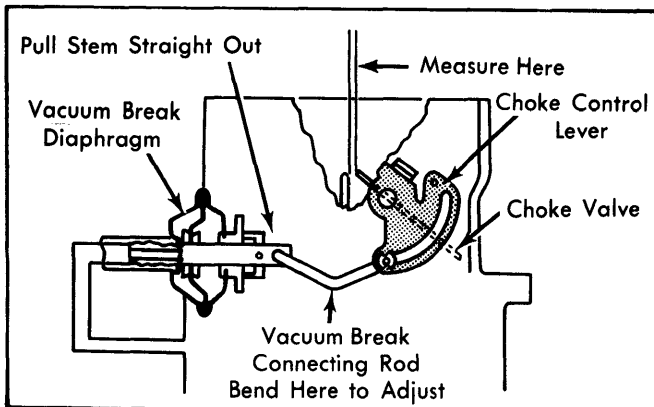

Fig. 2 Float Drop Measurement Point

## VACUUM BREAK

**Datsun** — Close choke and hold closed with rubber band stretched between choke piston and stationary part of carburetor. Grip stem of vacuum break diaphragm and pull straight outward (stem extended). Adjust gap between choke plate and air horn wall to .123-.147" (3.12-3.72 mm) on California models or .103-.127" (2.62-3.22 mm) on Federal models by bending vacuum break rod. See Fig. 3.

## HITACHI DCH 340 & DCR 342 2-BARREL (Cont.)



**Fig. 3 Vacuum Break Adjustment for Datsun Models**

**Isuzu & LUV** – Fully depress vacuum break diaphragm stem and measure clearance between choke plate and air horn wall. Adjust gap to .050-.059" (1.28-1.75 mm) on manual transmission models and to .055-.064" (1.40-1.63 mm) on automatic transmission models by bending vacuum break rod. See Fig. 4.

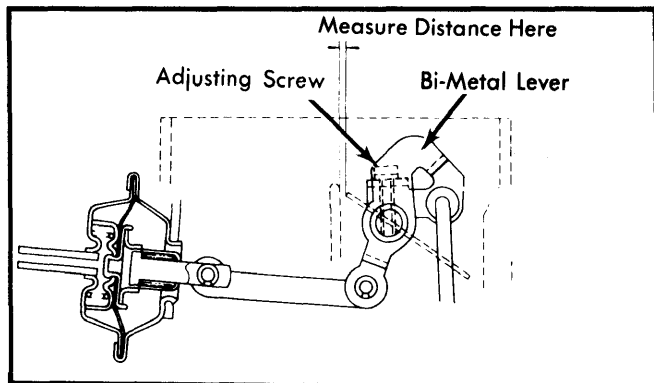

**Fig. 4 Vacuum Break Adjustment (Isuzu and LUV)**

### CHOKE UNLOADER

**Datsun** – 1) Close choke plate. Hold in position with a rubber band. Place throttle in wide open position.

2) Measure clearance between choke plate and air horn wall. Clearance should be as specified in table. Bend unloader tang to adjust. See Fig. 5.

**NOTE** – It is important to check that throttle valve opens fully when carburetor is mounted on vehicle. If throttle does fail to open, unloader becomes inoperative.

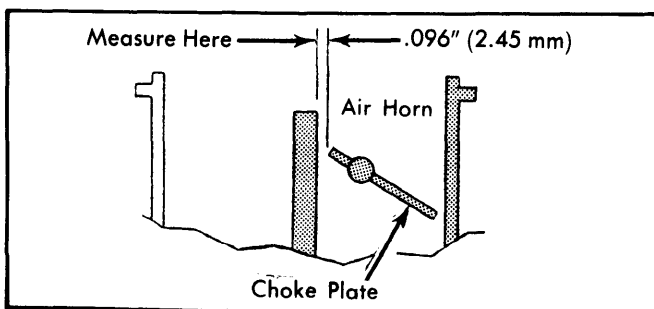
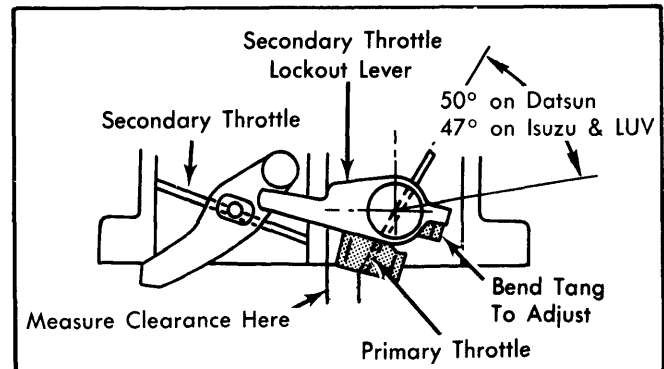

**Fig. 5 Datsun Choke Unloader Adjustment**

### SECONDARY THROTTLE INITIAL OPENING

When primary throttle valve opens 50° (47° on Isuzu and LUV), primary throttle lever tang contacts secondary throttle lockout. Any further opening of throttle valve will force secondary throttle lock-out lever to actuate secondary throttle lever and secondary throttle valve will begin to open. Check and adjust as follows:

Open primary throttle valve until it is observed that secondary is just beginning to open. Hold throttle in this position and measure clearance between primary throttle valve and throttle bore. If clearance is not to specifications, adjust by bending primary throttle tang. See Fig. 6.



**Fig. 6 Secondary Throttle Initial Opening Adjustment**

### CHOKE LINKAGE (FAST IDLE BENCH)

With fast idle screw on first step of fast idle cam, invert carburetor and close choke valve. Measure clearance (angle on Isuzu and LUV) between throttle plate and throttle bore. If adjustment is necessary, turn fast idle speed screw. Set clearance to .030-.035" (.76-.90 mm) on Datsun Man. Trans. or to .040-.043" (.96-1.1 mm) on Datsun Auto Trans. Set angle to 16-18° on Isuzu and LUV models. See Fig. 7.

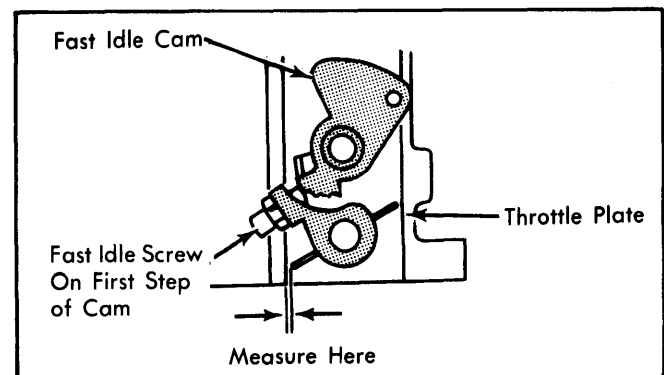

**Fig. 7 Choke Linkage Adjustment**

### OVERHAUL

**NOTE** – Procedure given is for LUV DCH340 Hitachi carburetor but can be applied to Datsun DCR342 Hitachi carburetor.

### DISASSEMBLY

1) With carburetor removed, perform the following steps:

- Disconnect accelerator pump lever.
- Remove throttle return spring.
- Remove choke thermostat housing and wire.

# 1981 Hitachi Carburetors

## HITACHI DCH 340 & DCR 342 2-BARREL (Cont.)

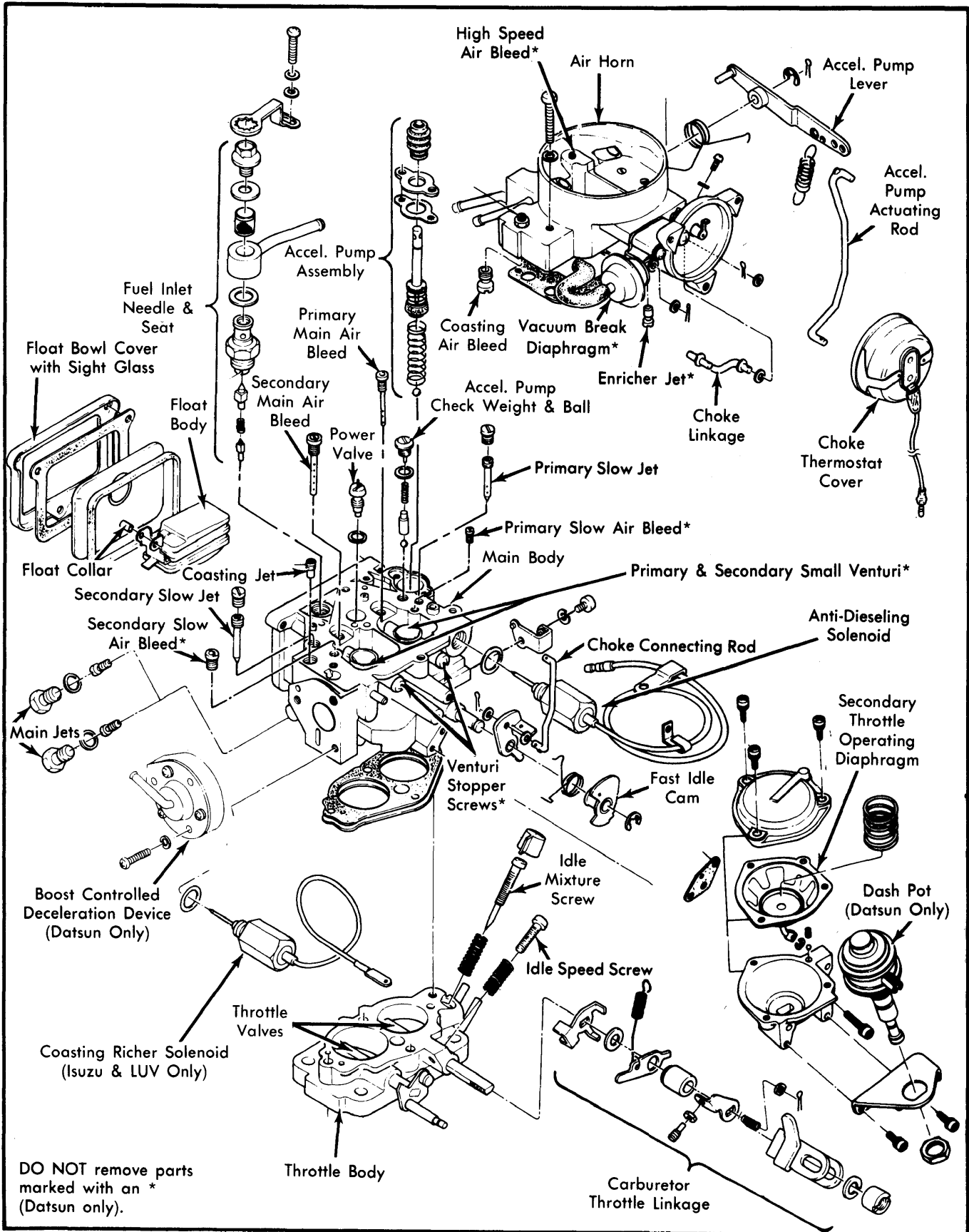

Fig. 8 Exploded View of Hitachi DCH & DCR Carburetor Assembly

## HITACHI DCH 340 & DCR 342 2-BARREL (Cont.)

- Remove fuel pipe nipple and strainer.
- Remove screw attaching choke lever to choke shaft.
- Move choke lever toward choke chamber.
- Remove choke connecting rod from counter lever.
- Disconnect vacuum hose from float chamber.

2) Remove bolts attaching choke chamber from float chamber. Remove choke chamber from float chamber, then perform the following steps:

- Remove cotter pin between diaphragm rod and secondary throttle lever.
- Separate lever and diaphragm.
- Remove the two solenoid valve harness clips.
- Remove diaphragm attaching screws.
- Remove diaphragm assembly.

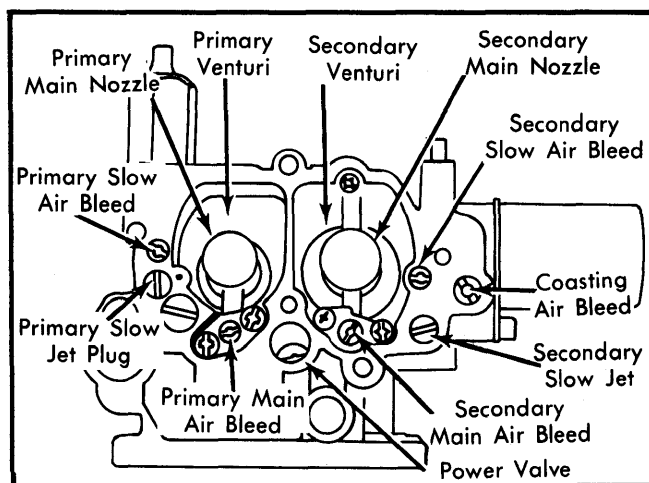

**Fig. 9** Location of Jets and Small Venturi in Float Chamber

3) Separate float chamber from throttle valve body. These parts are attached by one screw on the upper part and three screws on the lower part. One of the three lower screws is used to remove the negative pressure developed in the venturi. Remove this screw carefully.

4) Remove accelerator pump plunger attaching screws. Invert float chamber and remove plunger assembly. Then perform the following:

- Remove float needle valve assembly.
  - Remove float level gauge cover. Do not lose the float collar.
- 5) To disassemble rest of carburetor, proceed as follows:
- Remove screws attaching diaphragm cover.
  - Remove diaphragm cover, spring and diaphragm. Do not lose ball and small spring.
  - Remove all jets from upper part of float chamber.
  - Remove small venturi from both primary and secondary venturi on Federal Datsun models only.
  - Invert float chamber.
  - Remove small venturi from both primary and secondary venturi on all except Federal Datsun models.
  - Remove injector weight plug.
  - Invert float chamber and remove injector weight and ball.
  - Remove power jet, main jet plugs and main jets.
  - Remove primary vacuum jet.

**NOTE** — Do not remove throttle valves or choke valve unless components are damaged. Copyright (c) 2001 Mitchell Repair Information Company

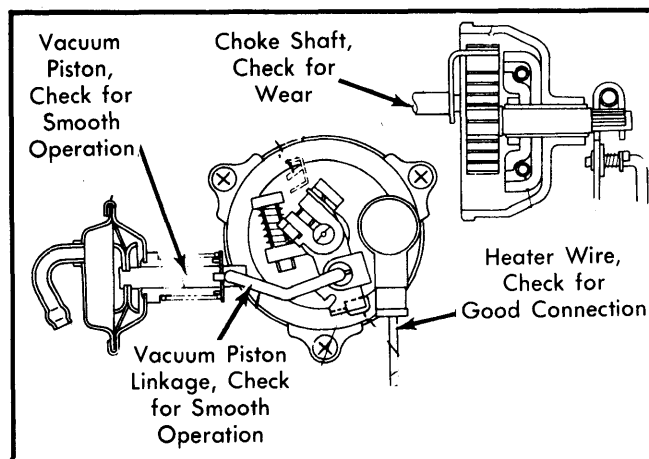

**Fig. 10** Inspection of Automatic Choke

### INSPECTION

**Choke Chamber** — Inspect chamber for cracks and damage particularly on joining face of chamber. Inspect choke shaft holes for wear, vacuum piston and choke valve for smoothness of operation. See Fig. 10.

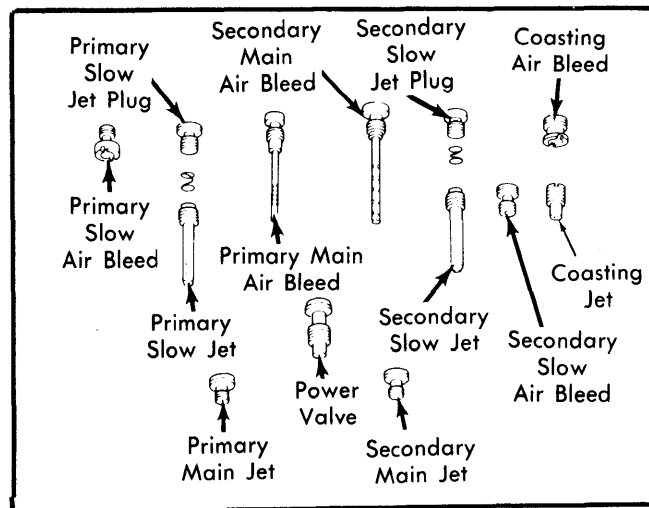

**Fig. 11** Metering Component Identification

**Float Chamber** — Inspect body for cracks, jointing surfaces and threaded holes for damage. Check power valve for leaks and smoothness of operation. Inspect float needle valve and float pin hole for wear. Check accelerator pump plunger for damage, wear and smoothness of operation.

**Throttle Chamber** — Check throttle valves and shafts for wear; slow and idle ports for clogging. Inspect mixture screw seating and mixture screw for step wear.

### REASSEMBLY

Reverse disassembly procedures and note following: Ensure jets are installed in correct positions. If choke and throttle valve have been removed, install valves making necessary adjustments and seal screws with a suitable wear. Check accelerator pump operation by filling cylinder with gasoline and operating plunger by hand.

# 1981 Hitachi Carburetors

## HITACHI DCH 340 & DCR 342 2-BARREL (Cont.)

CARBURETOR ADJUSTMENT SPECIFICATIONS								
Application	Fast Idle Opening Clearance In. (mm)		Float Level Setting In. (mm)	Float Drop Setting In. (mm)	Choke Linkage Setting In. (mm)	Secondary Throttle In. (mm)	Unloader Setting In. (mm)	Vacuum Break In. (mm)
	Man. Trans.	Auto Trans.						
Datsun 510	.030-.034 (0.76-0.90)	.039-.043 (0.96-1.10)	.283 (7.20)	.051-.067 (1.30-1.70)	.030-.035① (0.76-0.90)	.291-.330 (7.40-8.40)	.081-.112 (2.10-2.90)	.103-.127③ (2.62-3.22)
Pickup	.032-.037 (0.81-0.95)	.037-.044 (0.98-1.12)	.283 (7.20)	.051-.067 (1.30-1.70)	.030-.035① (0.76-0.90)	.291-.330 (7.40-8.40)	.081-.112 (2.10-2.90)	.103-.127③ (2.62-3.22)
Isuzu & LUV	②	②	③	.059 (1.50)	16-18°	.240-.300 (6.10-7.60)	....	.050-.059④ (1.28-1.75)

① - Auto. Trans. .040-.043" (0.96-1.10 mm).

② - 3200 RPM.

③ - Float parallel with top of float bowl. See adjustment procedure.

④ - Auto. Trans. .055-.064" (1.40-1.63 mm).

⑤ - California models .123-.147" (3.12-3.72 mm).