

AISAN 2-BARREL – TOYOTA 2F ENGINE

Land Cruiser

DESCRIPTION

Carburetor is a 2-barrel, downdraft type with vacuum operated choke breaker to improve cold engine operation. A secondary slow port helps fuel mixing at start of secondary valve opening. Improvement of operation is noticed during low speed load. A piston type accelerator pump is incorporated into the primary barrel and an auxiliary accelerator pump system aids in cold engine operation. Other equipment includes a diaphragm to open secondary valve at high speed and full throttle operation and a throttle positioner to prevent complete closing of throttle during deceleration. A throttle stop solenoid is also used to prevent dieseling during engine shut down.

CARBURETOR IDENTIFICATION

Application	Part No.
All Models	21100-61140

ADJUSTMENTS

HOT (SLOW) IDLE RPM

See appropriate *TUNE-UP SERVICE PROCEDURES* article.

IDLE MIXTURE

See appropriate *TUNE-UP SERVICE PROCEDURES* article.

COLD (FAST) IDLE RPM

See appropriate *TUNE-UP SERVICE PROCEDURES* article.

NOTE — It is recommended that Toyota carburetor adjusting kits 09240-00014 and 9240-00020 be used to make the following adjustments.

FLOAT LEVEL ADJUSTMENT

Turn air horn assembly upside-down. Measure clearance between upper surface of float and gasket surface of air horn. Bend center float tab until float level is correct. See Fig. 1

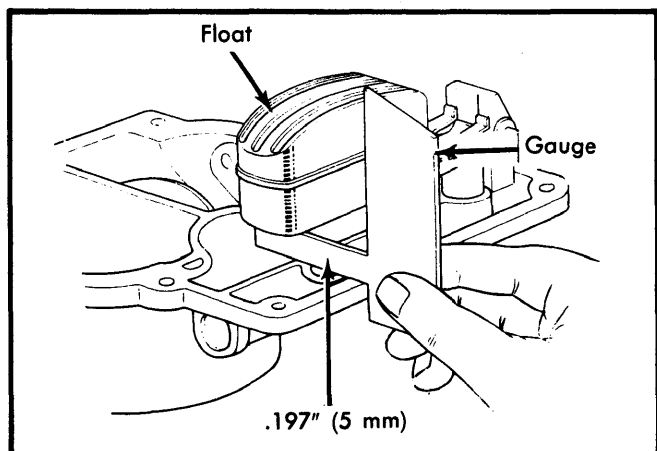

Fig. 1 Float Level Measurement Points

FLOAT DROP ADJUSTMENT

Lift up float assembly and measure clearance between needle valve plunger and float lip. Adjust clearance to specification by bending both outside float tabs. See Fig. 2.

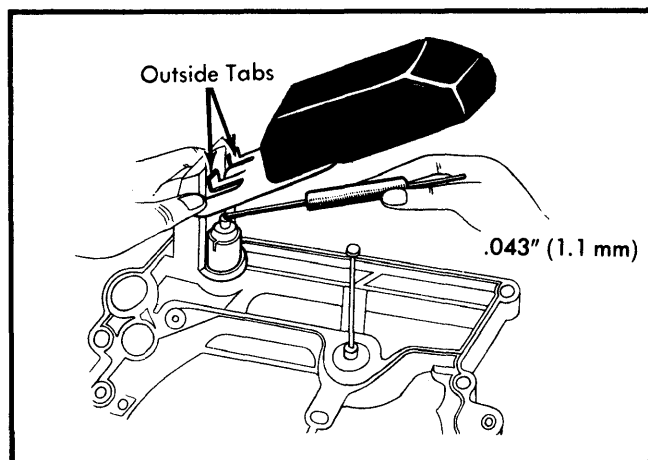

Fig. 2 Measuring Carburetor Float Drop with Gauge

PRIMARY & SECONDARY THROTTLE VALVE ADJUSTMENT

- 1) Open primary throttle valve. Then, open secondary throttle valve. Make sure valves are perpendicular to flange surface when fully opened.
- 2) Bend throttle lever stopper(s) until proper opening is obtained.

FAST IDLE (BENCH ADJUSTMENT)

Fully close choke valve. Check clearance between throttle bore and primary throttle valve. Adjust clearance to .051" (1.3 mm) by turning fast idle adjusting screw. See Fig. 3.

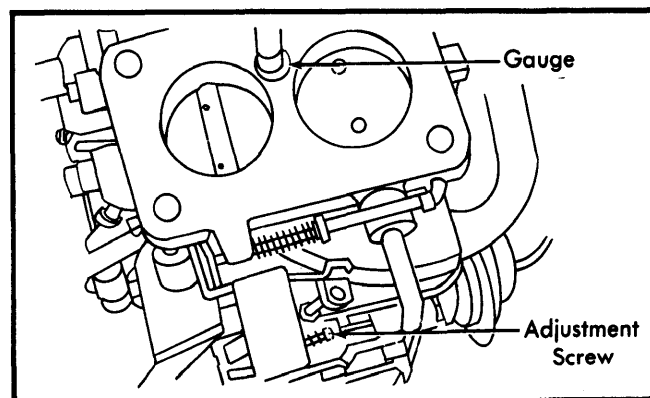

Fig. 3 Making Fast Idle Measurement and Adjustment

CHOKE BREAKER ADJUSTMENT

Push choke vacuum breaker diaphragm rod to open choke valve. Insert angle gauge. Set choke valve angle to 45° by bending choke-to-vacuum breaker diaphragm rod at existing bend. After adjustment, ensure smooth operation of choke valve. See Fig. 4.

1981 Aisan Carburetors

AISAN 2-BARREL - TOYOTA 2F ENGINE (Cont.)

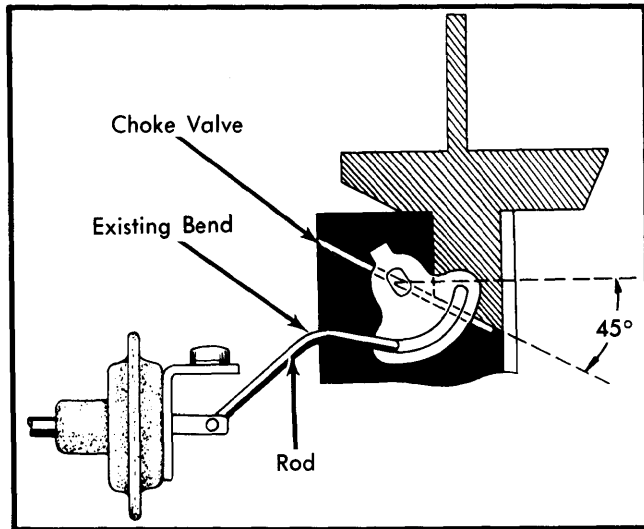

Fig. 4 Choke Breaker Adjustment

THROTTLE POSITIONER ADJUSTMENT

Turn carburetor upside-down and place throttle positioner adjusting screw against tab on throttle lever. Check clearance between throttle bore and primary valve. Adjust clearance to .031" (.8 mm) by turning throttle positioner adjusting screw. See Fig. 5.

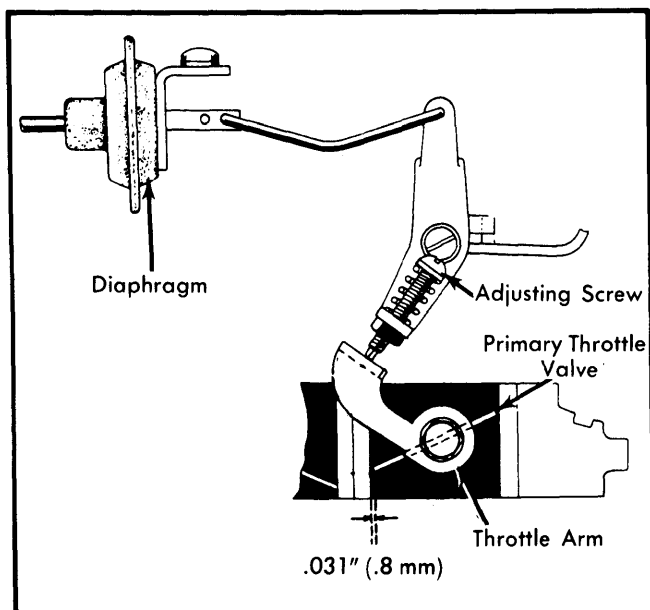

Fig. 5 Making Throttle Positioner Adjustment

SECONDARY THROTTLE OPENING ANGLE (KICK-UP)

Bend secondary throttle lever to obtain 25° angle between secondary throttle valve and bore when primary valve is fully open. See Fig. 6.

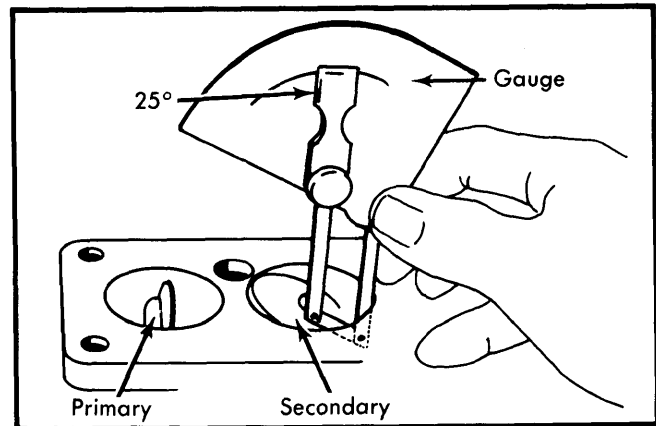

Fig. 6 Adjusting Secondary Throttle Opening Angle (Kick-Up)

OVERHAUL

NOTE - It is recommended that Toyota carburetor driver kit 09860-11010 be used during carburetor overhaul.

DISASSEMBLY

Body and Air Horn - Remove pump arm, pump connecting link, choke breaker connecting link, fast idle connecting link and throttle positioner assembly. See Fig. 7. Remove screws securing air horn to carburetor body and carefully lift off air horn assembly.

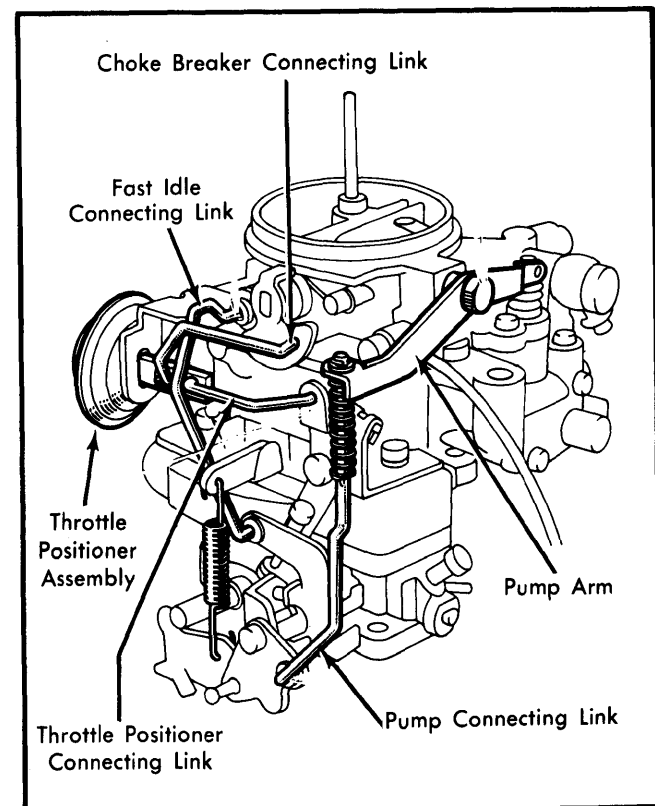

Fig. 7 Air Horn and Carburetor Body

AISAN 2-BARREL – TOYOTA 2F ENGINE (Cont.)

Air Horn – 1) Remove float assembly, needle valve and seat and pump plunger. Remove power piston retaining screw and retaining clip, then remove power piston and spring. Remove fuel shut-off solenoid. See Fig. 8.

NOTE – Perform step 2 only if required.

2) File off peened part of valve set screw and remove choke valve. Disconnect choke shaft return spring and pull out choke shaft.

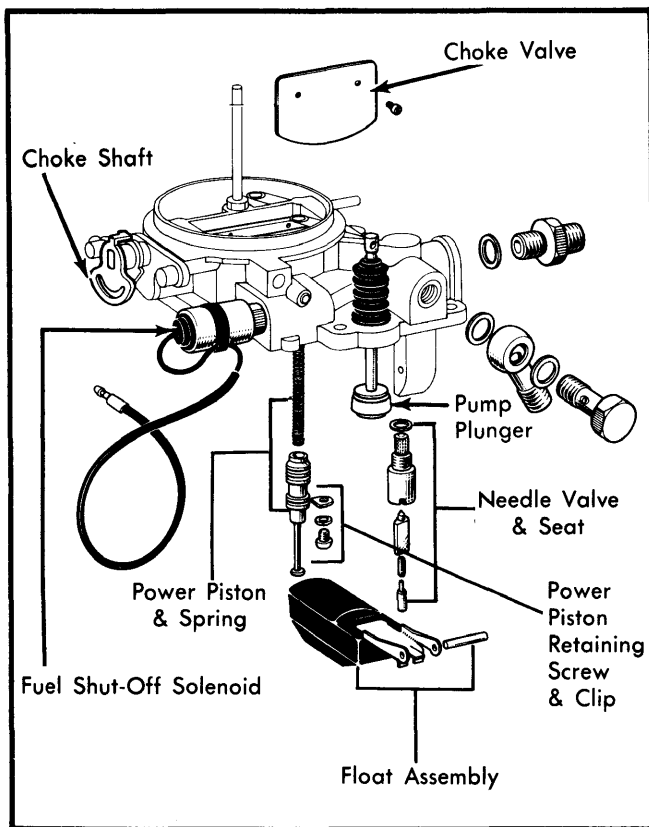

Fig. 8 Exploded View of Air Horn Assembly

Main Body – 1) Remove pump outlet check ball and spring, pump dampening spring and inlet check ball, and slow metering jets. See Fig. 9.

2) Loosen auxiliary accelerator pump (AAP) outlet screw plug, then remove outlet spring and check ball. Loosen AAP inlet screw plug, then remove check ball. Note size of check balls for reassembly reference.

3) Remove power valve. Remove primary and secondary main jet plugs and jets. Remove primary (triple venturi) and secondary (double venturi) venturi. Remove AAP diaphragm without turning adjusting screw. Remove secondary throttle valve diaphragm. Remove flange from carburetor body.

Flange Parts – Remove only those parts necessary for proper cleaning and inspection.

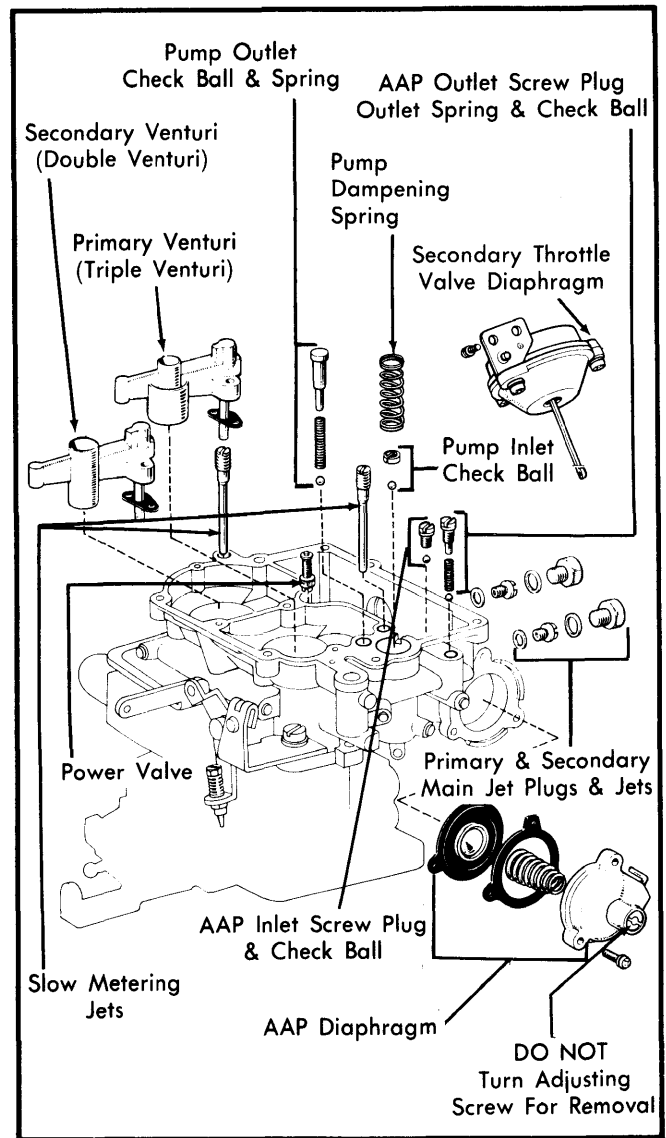

Fig. 9 Exploded View of Carburetor Main Body

CLEANING & INSPECTION

Clean all parts in suitable solvent (carburetor cleaner) and blow dry. Do not attempt to clean jets or other passages with wire or other metal objects. Inspect all parts for wear or damage and replace necessary parts.

REASSEMBLY

1) When assembling AAP diaphragm, spring should be installed with small end away from diaphragm or toward cover.

2) When installing venturi, primary venturi is triple venturi and secondary is double venturi.

3) When installing primary and secondary main jets, primary jet is "brass" colored and secondary jet is "chrome" colored.

1981 Aisan Carburetors

AISAN 2-BARREL – TOYOTA 2F ENGINE (Cont.)

4) When installing AAP check balls, smaller ball is installed in pump inlet (inside fuel bowl) and larger ball and spring is installed in pump outlet (outside fuel bowl).

5) When installing slow metering jets, larger (longer) jet is installed on secondary side.

6) When installing choke valve, peen over choke valve retaining screws.

7) Make sure power piston operates smoothly after installing retaining clip and screw.

8) Make sure that needle valve, spring and plunger are properly installed in correct order. Float must be correctly adjusted.

9) When installing air horn to main body, take care not to damage pump plunger leather.

CARBURETOR ADJUSTMENT SPECIFICATIONS								
Application	Idle Speed (Engine RPM)		Float Level Setting In. (mm)	Float Drop In. (mm)	Fast Idle Opening Clearance In. (mm)	Choke Breaker Angle	Accel. Pump Stroke In. (mm)	Throttle Positioner In. (mm)
	Hot	Fast						
Land Cruiser	650 ^①	1800 ^②	.197 (5)	.043 (1.1)	.051 (1.3)	45°	.374 (9.5)	.031 (.8)

① – Mixture speed – 690 RPM.

② – EGR and evaporation systems off and vacuum advance cut.