

TUNE-UP

911SC

ENGINE IDENTIFICATION

Engine identification number is stamped on engine crankcase near oil temperature sensor. The first three digits in engine number identify engine type and year.

Application	Engine Type	Code
911SC	930/16	641

COMPRESSION PRESSURE

Perform compression test with wide open throttle and oil temperature not less than 140°F (60°C). Remove all spark plugs and allow about 12 piston strokes per cylinder test. Pressure difference between cylinders should not exceed 22 psi (1.5 kg/cm²).

Compression Pressure Specifications

Application	Pressure psi (kg/cm ²)
Normal	142-184 (10-13)
Minimum	107 (7.5)
Maximum Variation	22 (1.5)

VALVE CLEARANCE

Adjust valve clearance to specifications with engine cold.

Valve Clearance Specifications

Application	Clearance
All Models (Intake & Exhaust)	.004" (.1 mm)

VALVE ARRANGEMENT

Engine cylinders have individual heads and contain one intake and one exhaust valve per head. Upper valves are intake and lower valves are exhaust.

SPARK PLUGS

Application	Gap In. (mm)	Torque Ft. Lbs. (N·m)
911SC	.028 (0.7)	22 (30)

Spark Plug Type

Application	Bosch No.
911SC	W225T30 (WD5)

HIGH TENSION WIRE RESISTANCE

Carefully remove high tension wires from spark plugs and distributor cap. Using an ohmmeter, check high tension wire resistance while gently twisting wires. If resistance is not to specifications, or fluctuates from infinity to any value, replace high tension wire(s).

Resistance (Ohms) Per Wire

Application	Ohms
All Models	25,000-30,000

DISTRIBUTOR

All models use Bosch breakerless electronic distributors. No adjustments are necessary.

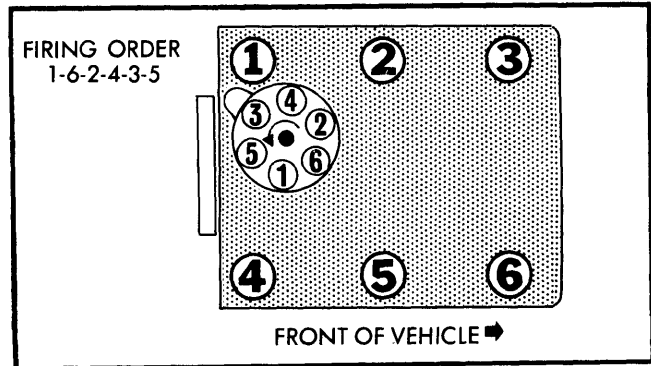

Fig. 1 Firing Order and Distributor Rotation

IGNITION TIMING

Warm engine to normal operating temperature and disconnect both distributor vacuum lines. Connect tachometer and timing light. With engine idling, rotate distributor until mark on pulley is lined up with reference mark on blower housing.

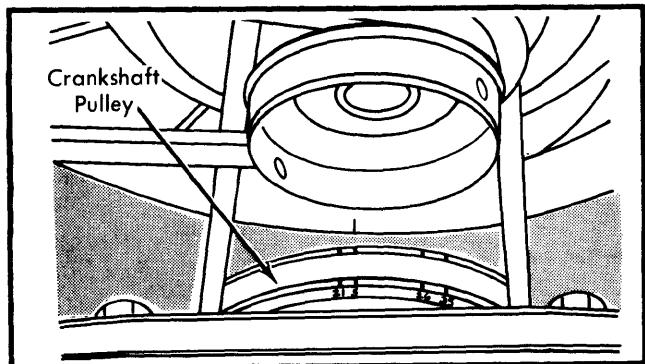

Fig. 2 911 Ignition Timing Marks

Ignition Timing Specifications (Degrees BTDC @ RPM)

Application	Timing
911SC	5@850-950

IDLE SPEED & MIXTURE

1) Engine should be at normal operating temperature and oil filler cap must be tightly sealed. Connect CO level meter to pickup point on catalytic converter and connect tachometer to ignition control box black/purple wire.

2) Disconnect plug from oxygen sensor (left side of engine compartment). Turn idle by-pass screw on throttle housing to obtain correct idle RPM. If mixture must be adjusted, remove plug from mixture control unit.

3) Insert adjusting tool and rotate clockwise to richen mixture; counterclockwise to lean mixture. Turn tool in small amounts without pressing down. Be sure to remove tool and plug opening before accelerating engine or testing mixture.

TUNE-UP (Cont.)

4) Accelerate engine briefly, then allow idle to stabilize before taking readings. When CO level is correct, check idle speed and readjust if necessary. Remove test equipment, coat threads of test point cap (on converter) with anti-seize compound, and reconnect oxygen sensor.

Idle Speed & CO Level

Application	Idle RPM	CO%
All Models	850-950	0.4-0.8

FUEL PUMP PRESSURE & VOLUME

Pressure	65-75 psi (4.5-5.2 kg/cm ²)
Volume	1.5 pts. in 30 sec.

EXHAUST EMISSION SYSTEMS

See EXHAUST EMISSION SYSTEMS section.

GENERAL SERVICING

IGNITION

DISTRIBUTOR

All models are equipped with Capacitive Discharge Ignition systems with Bosch breakerless distributors.

IGNITION COIL

Coil Resistance (Ohms@68°F)

Application	Primary	Secondary
All Models	0.4-0.6	600-790

FUEL SYSTEMS

FUEL INJECTION

All models are equipped with Bosch Lambda Continuous Injection System (CIS) with oxygen sensor.

ELECTRICAL

BATTERY

Application	Amp. Hr. Rating
All Models	66

Battery Location — Battery is located on left in front luggage compartment, under the floor mat.

STARTER

Bosch Overrunning Clutch

Starter Specifications

Application	Volts	Amps	Test RPM
911SC	11.5	50-80	7300-9300

ALTERNATOR

Application	Rated Amp. Output
All Models	70

ALTERNATOR REGULATOR

All models are equipped with Bosch or Motorola alternator regulators with an operating voltage of 13.5-14.5 volts at 2500 RPM.

BELT ADJUSTMENT

Belt should deflect from 1/4-1/2" (5-10 mm) when light thumb pressure is applied halfway between pulleys. Adjustment is made by removing or adding spacers between pulley halves. Rotate belt several times and recheck adjustment after changing spacers.

FILTERS

Filter	Service Interval (Miles)
Oil Filter	Replace every 15,000
Air Filter	Replace every 30,000
Fuel Filter	Replace every 30,000

CAPACITIES

Application	Quantity
Crankcase	
Total Capacity	13.7 qts.
Oil Change	10.6 qts.
Transaxle (SAE 90)	
911SC	3.2 qts.
Fuel Tank	Ⓢ21 gals.

Ⓢ — Includes 2.1 gals. in reserve.