

Maintenance Reminder Light

1980-88 RESET PROCEDURES IMPORTED CARS & TRUCKS

ACURA LEGEND

SYSTEM CHECK LIGHT

1) Every 7500 miles, "SCHEDULED SERVICE DUE" light will come on as a reminder to change oil and oil filter.

2) When engine oil and oil filter change has been completed, reset reminder light. To reset reminder light, open "SERVICE CHECK" button. With ignition switch in the "ON" position, press reset button for 3 seconds. To verify, turn the ignition switch "OFF" and "ON", light should not come on.

Fig. 1: Acura Legend LS Module & Reset Button

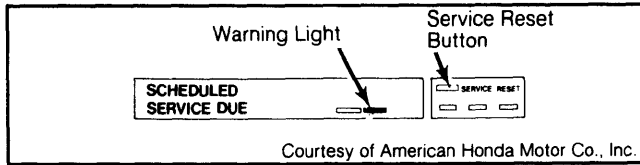

ALFA ROMEO

OXYGEN SENSOR WARNING LIGHT

1) Every 30,000 miles on Spider 2.0L, Graduate and Quadrifoglio, and 60,000 on GTV-6 2.5L, a light on the dash will illuminate. This is a reminder to check the system and replace the oxygen sensor.

2) To turn off light (after replacing sensor) on Spider 2.0, Graduate and Quadrifoglio, locate mileage counter on left side of engine compartment. Remove plastic cover by drilling through shank of attaching screws. Remove cover, rotate and press button. Reinstall cover using new screws.

3) On GTV-6 2.5L, remove the ECU cover panel and lower right side parcel shelf. Locate mileage counter under right side of dash. Push White reset button. Ensure emission reminder light is out.

AUDI

EGR WARNING LIGHT

EGR light will come on every 15,000 miles of operation. After EGR system is checked, and any defects corrected, reset mileage counter.

OXYGEN SENSOR WARNING LIGHT

1) Every 30,000 miles a reminder light in the dashboard will illuminate. This indicates that emissions system should be checked and the oxygen sensor (if equipped) replaced.

2) To reset counter on 1984-88 4000 and 5000 non-turbo and 5000S models, remove 2 upper and 2 lower instrument cluster cover screws. Pull cover towards steering wheel.

3) Lift upper instrument cluster cover off of cluster. Break off square plastic switch cover at top center near imprinted "OXS". Using a screwdriver, push switch to reset light. On some 1984 models it may be necessary to remove instrument cluster to gain access to switch.

4) On 1984-88 5000 Turbo, lift rear seat and push button marked "OXS" on reset box. Cycle ignition to "ON" position and verify light is out.

Fig. 2: Resetting Audi In-Dash Mileage Counter

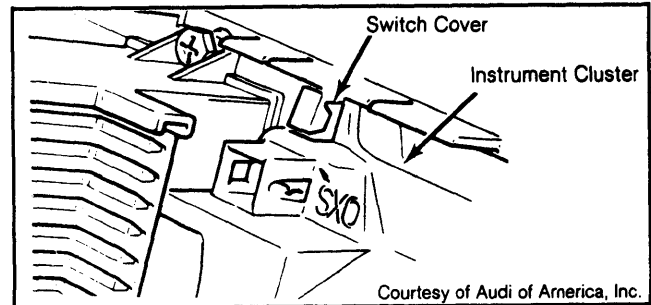

5) To turn off reminder light on all others, trace speedometer cable to the reset box (in-line with the cable). To reset, press White button on box and ensure reminder light is out.

Fig. 3: Resetting Audi In-Cable Mileage Counter

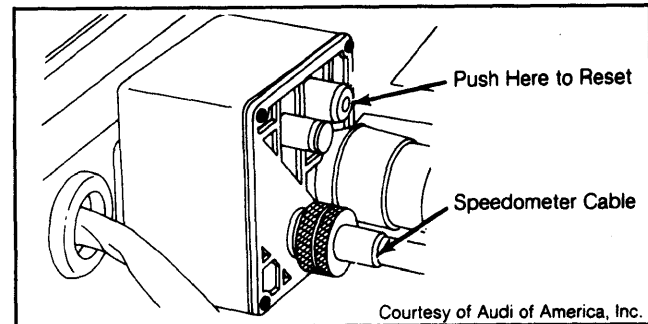

BMW

OXYGEN SENSOR WARNING LIGHT

All Models Before 1983

1) Every 30,000 miles (25,000 on 528i) the "OXYGEN" light in the dash will illuminate as a reminder to replace the oxygen sensor.

NOTE: On 528e and 1983 633CSi models, pull the protective metal plate off before removing the oxygen sensor.

2) After replacing sensor on 528e and 1983 633CSi models, remove instrument panel. Turn it over and remove the bulb for "OXYGEN" light. No interval reset switch is provided.

Fig. 4: Location of BMW Interval Switch

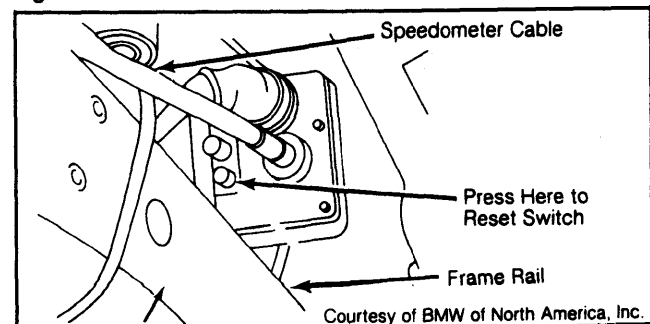

1980-88 RESET PROCEDURES IMPORTED CARS & TRUCKS (Cont.)

3) On all other models, reset the interval switch. Trace speedometer cable to switch (in-line with cable, mounted on the frame rail left of transmission). Press White reset button. Ensure light on dash is out.

SERVICE INTERVAL REMINDER LIGHTS

All 1983 & Later Models

1) On 1983 and later models, the service indicator consists of 5 Green, one Yellow and 3 Red Light Emitting Diodes (LED) and the inscriptions "OIL SERVICE" and "INSPECTION". Whenever the ignition is switched on, up to 5 Green LED's will light up.

2) The Green LED's go out when the engine is started. If the Yellow LED lights and one of the inscriptions also come on with the ignition and remain on when the engine is started, maintenance service is due immediately.

3) When maintenance interval has been exceeded (after approximately 1000 miles) the Red LED lights will come on in addition to the Yellow light as a reminder for servicing. Special Service Indicator Resetter (62 1 100) is required to reset the computer.

4) If resetter is not available, switch off all electrical accessories. Turn ignition on and verify presence of 5 volts at terminal No. 7 (Blue/White wire) of the Diagnostic Connector (on thermostat housing) using a digital volt/ohmmeter (10-megohm impedance recommended).

5) Using digital voltmeter, connect negative lead to ground and positive lead to terminal No. 7 of the connector. Turn ignition switch to the "ON" position. Ground terminal through voltmeter for 12 seconds.

6) All Green lights should illuminate, indicating reset has occurred.

OXYGEN SENSOR WARNING LIGHT

When oxygen sensor light is illuminated, service sensor and remove bulb from indicator. No reset switch is provided.

NOTE: Late production (since February 1985) BMW models have a reset button on the rear of the light control assembly that is located near the pedal assembly. Press button to reset light after servicing oxygen sensor.

CHRYSLER MOTORS

EGR WARNING LIGHT

1) On some carbureted models, an "EGR" or "MAINTENANCE REQUIRED" warning light in the dash will come on as a reminder to have the EGR system inspected and/or serviced every 50,000 miles.

2) After inspection and/or servicing EGR system, reset the mileage sensor. The reset switch is located on the back of the instrument panel on the left of the speedometer cable junction or below it. Slide the switch to the other side to reset the sensor light.

**Fig. 5: Resetting Chrysler Motors
EGR Warning Light**

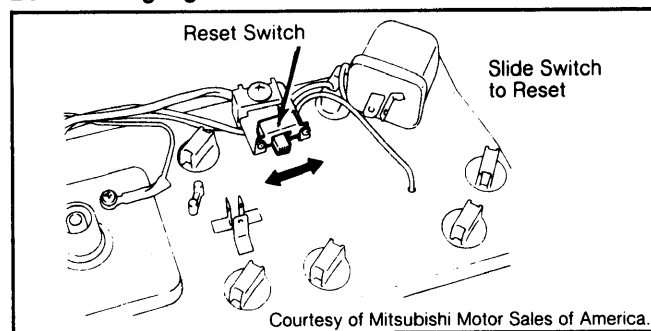

DATSUN

See NISSAN.

FIAT

OXYGEN SENSOR WARNING LIGHT

1) All Fiats with fuel injection are equipped with an oxygen sensor. After 30,000 miles of operation, a warning light in the dash will illuminate, indicating that the sensor must be replaced.

2) To reset mileage counter (after replacing sensor), locate switch unit. On Brava, the switch is located behind the dash on the left hand side. On Strada, it is under the dash between the glove box and the radio.

3) On Spider 2000, the switch is located under the left side of the dash, above the accelerator pedal and on X 1/9, behind the center console.

4) To reset switch, cut retaining wire and remove screw. Insert small screwdriver through housing and press switch contact. This resets switch and turns out "EX GAS SENSOR" light. Install the cap screw and secure with new wire.

Fig. 6: Fiat Oxygen Sensor Switch Unit

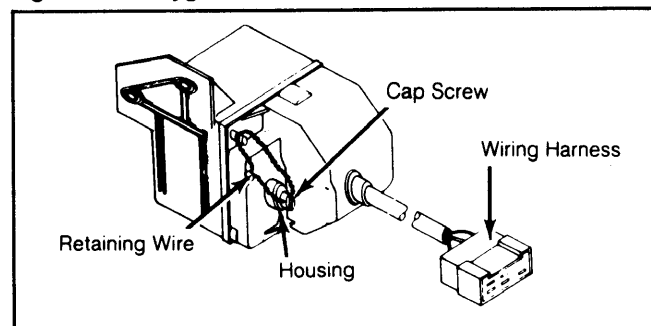

Reset switch at 30,000 mile intervals.

Maintenance Reminder Light

1980-88 RESET PROCEDURES IMPORTED CARS & TRUCKS (Cont.)

FORD MOTOR CO.

1988 PASSENGER CARS

Non-EEC Equipped

Ford Motor Co. imported 1988 non-EEC equipped passenger cars use a maintenance reminder light to indicate emission system maintenance is required. Control unit (timer) for maintenance light is located under dash near steering column or behind glove box. Maintenance light is triggered after 2000 key starts (about 60,000 miles). To reset light on models with resettable timer (after emission servicing), proceed as follows:

1) Turn key switch off. Remove tape over reset hole in timer. Lightly push a Phillips screwdriver into hole in timer unit marked "RESET". With light pressure on screwdriver, turn key switch to "RUN" position.

2) Light should stay on while screwdriver is pressed down. Hold screwdriver down for approximately 5 seconds. Remove screwdriver. Light goes out within 2-5 seconds. If not, repeat steps 1) and 2).

3) Cycle ignition from "OFF" to "RUN" position. Light should glow for 2 to 5 seconds. This verifies proper reset of maintenance reminder light.

NOTE: Some models use a non-resettable control unit. Replace it with a resettable type. Non-EEC vehicles for 1988 are the 1.3L Festiva and 1.6L Tracer.

GENERAL MOTORS

OXYGEN SENSOR WARNING LIGHT

1) On Spectrum and Sprint models, at 30,000 mile intervals, a "SENSOR" light will start flashing in the dash. This indicates the ECM is in good condition and the oxygen sensor needs replacement.

2) To reset light on Spectrum (after replacing sensor), turn ignition key to "OFF" position and remove "ECM" fuse. Removing this fuse for a 10 second period will clear ECM codes.

3) On Sprint, locate "SENSOR" light cancel switch on right side of fuse box. Return cancel switch to "OFF" position. Start engine to verify light is off.

HONDA

SERVICE INTERVAL REMINDER

On 1982-85 Accord models, oil, filter and service interval indicator flags activate after every 7500 miles of operation. To reset indicators, insert ignition key into slots below indicator flags at lower right corner of instrument cluster. Push key in until reminder window changes from Red to Green.

JAGUAR

OXYGEN SENSOR WARNING LIGHT

1) All fuel-injected Jaguars are equipped with an oxygen sensor. When the warning light on the dash comes on (at 30,000 mile intervals), replace the sensor.

2) To reset counter (after replacing sensor), locate the interval counter (in-line with speedometer cable). Reset counter using Key (BLT-5007) supplied in kit with new sensor.

3) Models with electronic speedometers have a mileage counter in the trunk. The counter is behind the left side trim adjacent to the wheel arch behind panel at rear of seat. The reset button is White.

MAZDA

EGR WARNING LIGHT FEDERAL B2000 PICKUP

1) Warning light will come on at 60,000 miles, indicating EGR system should be serviced. To reset warning light (after service), locate Black wire and Green wire connector under dash (above and to left of fuse box).

2) Unplug connector. Leave disconnected. Light will not come on again.

TIMING BELT WARNING LIGHT DIESEL PICKUP

1) To reset warning light, locate Black wire and Black/Yellow and Black/White wires near the intermittent wiper unit.

2) Remove Black wire from Black/White or Black/Yellow wire connector.

3) Reconnect Black wire to opposite wire from which wire was originally removed.

MERCEDES-BENZ

OXYGEN SENSOR WARNING LIGHT

1980-85 Models

1) When the "OX-SENSOR" light comes on (at 30,000 miles), the oxygen sensor must be replaced and mileage counter reset.

2) To reset counter on 280 series vehicles, locate mileage counter in-line with the speedometer cable, under instrument panel. Disconnect wiring plug from counter and leave disconnected. No reset switch is provided.

3) To reset counter on all other series, instrument cluster must be partially removed. Insert a hooked steel wire between right side of cluster and dashboard. Turn hook to engage cluster and pull cluster out of spring retaining clips. Remove bulb from lower corner of cluster. Press cluster back into position. No reset switch is provided.

1980-88 RESET PROCEDURES IMPORTED CARS & TRUCKS (Cont.)

Fig. 7: Mercedes-Benz 280 Mileage Counter

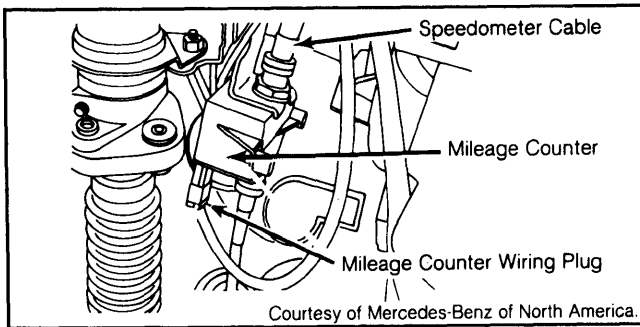

1986-88 Models

The "O₂ SENSOR" light on these models is used as a malfunction indicator for the O₂ sensor/circuit. There is no mileage counter. No reset procedure is required. Servicing and repairing the O₂ sensor/circuit should turn light off.

MITSUBISHI

See CHRYSLER MOTORS.

NISSAN

CHECK ENGINE LIGHT

1988 Nissan models are equipped with on-board self diagnosis. The "CHECK" engine light will come on when the control unit senses an emission system malfunction. As a bulb test, the light will come on when the ignition switch is turned to the "ON" position. There is no reset procedure for this light. If emission system requires diagnosis, see appropriate COMPUTERIZED ENGINE CONTROL article in MITCHELL'S TUNE-UP/MECHANICAL, TUNE-UP OR COMPUTERIZED ENGINE CONTROLS manuals.

OXYGEN SENSOR WARNING LIGHT

1) Most Datsun and Nissan models utilize an oxygen sensor. After 30,000 miles of operation, the oxygen sensor light in the dash will come on. This light indicates that the sensor should be inspected. If sensor is faulty, it must be replaced.

2) After sensor is inspected and/or replaced, turn off the "SENSOR" light. For this procedure, most models provide a wire harness connector which is disconnected to turn the light off. Leave disconnected. See Fig. 8. Some newer models use a reset relay located behind left or right kick panel, center console or under a seat. To reset relay, go to Step 5). See Fig. 9.

3) On 1985-86 Federal Pickups, disconnect Yellow/White harness at 50,000 and Yellow/Black harness at 100,000 miles. On 1985-86 Calif. Pickups, disconnect Yellow wire harness at 90,000 miles. Harnesses are located above hood release cable.

4) On models WITHOUT sensor light relays, see the NISSAN SENSOR LIGHT CONNECTOR LOCATIONS chart to locate the SINGLE warning light harness connector. Unplug the connector and leave disconnected. The reminder light will no longer function.

Fig. 8: Nissan Oxygen Sensor Warning Light Harness

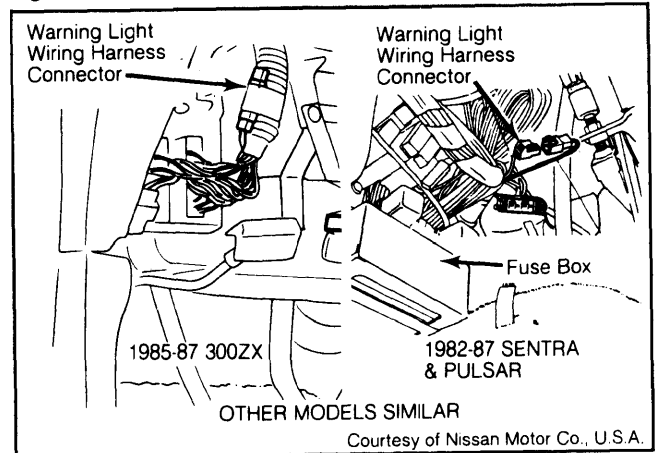
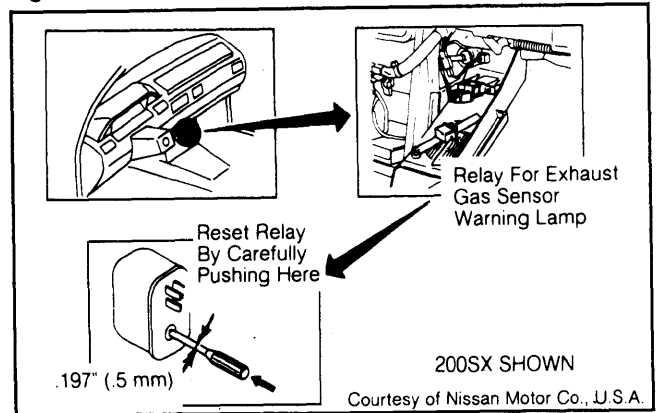

Fig. 9: Nissan Oxygen Sensor Light Relay



5) On models WITH sensor light relays, locate relay. See the NISSAN SENSOR LIGHT RELAY LOCATIONS chart. To reset the relay push reset button on relay or remove tape over reset hole and insert a small screwdriver into reset hole. Push lightly to reset. Reset relay at 30,000 and 60,000 miles. At 90,000 miles, locate and disconnect warning light wire connector. See the NISSAN SENSOR LIGHT CONNECTOR LOCATIONS chart.

NISSAN SENSOR LIGHT RELAY LOCATIONS

Application	Location
Maxima	
1985-86	Left Kick Panel
1987	Right Kick Panel
Pickup (Calif.)	
1986	Right Kick Panel
Pulsar/Pulsar NX	
1986	Right Kick Panel
1987	Left Kick Panel
Sentra	
1986-87	Right Kick Panel
Stanza	
1986-87	Right Kick Panel
Stanza Wagon	
1986-87	Under Right Seat
200SX	
1985 1/2-87	Behind Grille, Left of Console
300ZX	
1986-87	Near Glove Box

Maintenance Reminder Light

1980-88 RESET PROCEDURES IMPORTED CARS & TRUCKS (Cont.)

NISSAN SENSOR LIGHT CONNECTOR LOCATIONS

Application & Wire Color	Location
Maxima & Maxima/810	
1980-84	
Yellow/Blue	Near Hood Release
1985-87	
Green/Red-Green/White	Near Hood Release
Pickup	
1980-84	
Yellow/White	Near Hood Release
Pulsar/Pulsar NX	
1983-86	
Lt. Green/Blk-Lt. Green or Blk/White-Blk/White	Near Fuse Box
1987	
Red/Black-Red/Blue	Above Fuse Box
Sentra	
1982-83	
Green-Yellow or Green/Black	Above Fuse Box
1984	
Lt. Green/Black-Lt. Green	Near Hood Release
1985-86	
Lt. Green/Black	Above Fuse Box
1987	
Red/Blue-Red/Black	Above Fuse Box
Stanza	
1984-86	
Yellow/Red or Yellow-Yellow/Green	Behind Left Kick Panel
1987	
Green-Brown	Above Fuse Box
Stanza Wagon	
1986-87	
Red-Yellow or Red/Blue ..	Behind Instrument Panel
200SX	
1980-84	
Green/White	Under Far Right Side Dash
1985-87	
Pink-Purple	Behind Fuse Box
280ZX	
1982-83	
Green/Yellow	Under Right Side Dash
300ZX	
1984	
White (Connector)	Behind Left Kick Panel
1985-86	
White (Connector)	Above Hood Release
1987	
Gray/Red-Gray/Yellow	Above Hood Release

PEUGEOT

EGR WARNING LIGHT

1) All 1980 604 models are equipped with an "EGR" warning light. The light comes on at 12,500 mile intervals as determined by a mileage counter. When light comes on, perform EGR service. After service, reset mileage counter.

2) To reset mileage counter, unbolt the maintenance switch from inside of left front wheel well. Pull down switch without disconnecting speedometer cables.

3) Remove covers (outer and inner) from counter and turn reset button counterclockwise until reaching a stop point. This resets counter to zero. Ensure warning light is out. Replace covers and reinstall counter.

OXYGEN SENSOR WARNING LIGHT

1) All 505 models with gasoline engines are equipped with an oxygen sensor warning light. The light comes on at 30,000 mile intervals. When the warning light comes on, the oxygen sensor must be replaced and the mileage counter reset.

2) To reset mileage counter, locate switch below brake master cylinder and remove plastic cover and plug. Use small punch or rod to press reset button. Replace plug and cover.

Fig. 10: Resetting Peugeot Mileage Counter

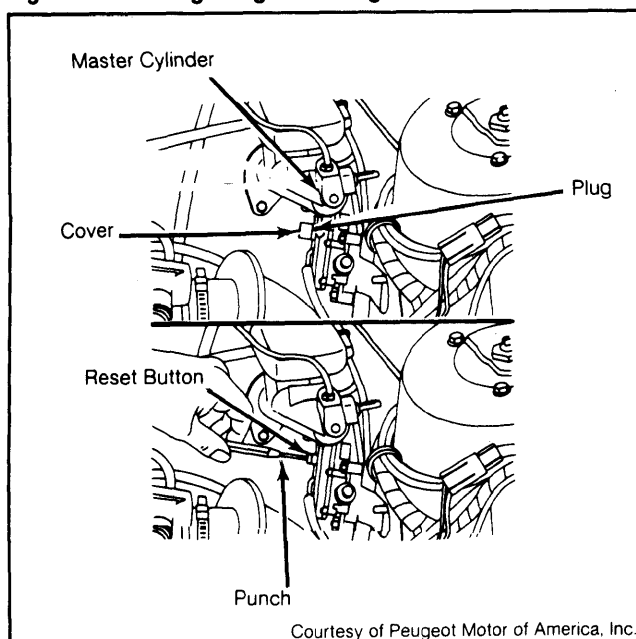

Courtesy of Peugeot Motor of America, Inc.

PORSCHE

OXYGEN SENSOR WARNING LIGHT

All models are equipped with an oxygen sensor. On all models except 928S (with LH Jetronic system) and 944, an "OXS" light will come on at 30,000 mile intervals as a reminder to replace the sensor. The 928S (with LH Jetronic system) and 944 do not use a warning light. On these models, however, it is recommended that the oxygen sensor be replaced every 60,000 miles.

REPLACING OXYGEN SENSOR

1) On 911 models, locate oxygen sensor plug on left side of engine compartment, just below ignition coil. Disconnect wire at plug and push grommet and plug through the grommet hole. Raise vehicle.

2) Remove left rear wheel. Remove exhaust shield. Locate oxygen sensor on exhaust manifold and pull safety plug off sensor. Remove sensor.

1980-88 RESET PROCEDURES IMPORTED CARS & TRUCKS (Cont.)

3) Coat threads of new sensor with anti-seize compound, using care not to get any in the sensor slot. Install sensor.

4) On 924 and 944 models the sensor is located in the exhaust pipe and extends through a hole in the sheet metal. Raise vehicle. Locate sensor and trace wire back to plug connector. Disconnect wiring. Pull plug off oxygen sensor. Remove sensor.

5) Install new sensor with anti-seize compound on threads. Do not get any compound in the slot of the sensor.

6) On 928 models, the sensor wire connector is located inside the vehicle behind the lower section of the foot support on passenger side. Disconnect wiring plug and push grommet and plug out through floor board.

7) Raise vehicle. Locate the oxygen sensor in the exhaust pipe and remove safety plug from sensor. Remove sensor.

8) Install new sensor with anti-seize compound on threads. Do not get any of the compound in the slot of the sensor.

RESETTING MILEAGE COUNTER

1) On 911 models, disconnect battery ground cable and remove speedometer. The counter will be visible through speedometer mounting hole.

2) Use a thick piece of wire or a thin rod to press White reset button. Push button all the way in against stop. Ensure warning light is out.

3) On 924 models, after replacing oxygen sensor and with vehicle still raised, locate the mileage counter on the left engine mount and use a thick wire or thin metal rod to push in reset button. Be sure to push button in all the way to stop. Ensure "OXS" light is out.

4) On 928 and 928S (with CIS system) models, the counter is located at the right of the passenger seat floor. Remove the counter cover retaining screw and cover. Press reset button all the way in against stop. Ensure warning light is out.

2) To reset mileage counter (after replacing sensor), locate counter in-line with speedometer cable. Cut retaining wires and remove cover by disengaging clips.

3) Turn reset button 1/4 turn counterclockwise towards "O" mark to reset counter. Check that "OXYGEN SENSOR" light is out. Replace cover and secure with new wires.

SAAB

OXYGEN SENSOR WARNING LIGHT

1) All models use an oxygen sensor as part of the exhaust emissions system. On all models except 1985-87 Turbo, the "EXH" maintenance light on the dash comes on every 30,000 miles. The oxygen sensor should be replaced at this time. Turbo models for 1985-87 do not use "EXH" maintenance light. On these models, replace oxygen sensor every 60,000 miles.

2) To reset mileage counter for "EXH" light, press reset button on counter unit. The unit is located at flasher relay under instrument panel. Reach under knee panel (or down through left defroster outlet), locate unit, and press reset button. See Fig. 12.

Fig. 12: Resetting Saab Mileage Counter

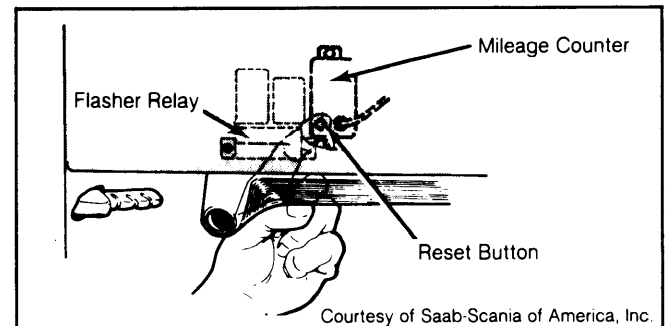

RENAULT

OXYGEN SENSOR WARNING LIGHT

1) On models equipped with an oxygen sensor, a dash mounted warning light comes on at 30,000 mile intervals as a reminder to replace the sensor.

Fig. 11: Resetting Renault Mileage Counter

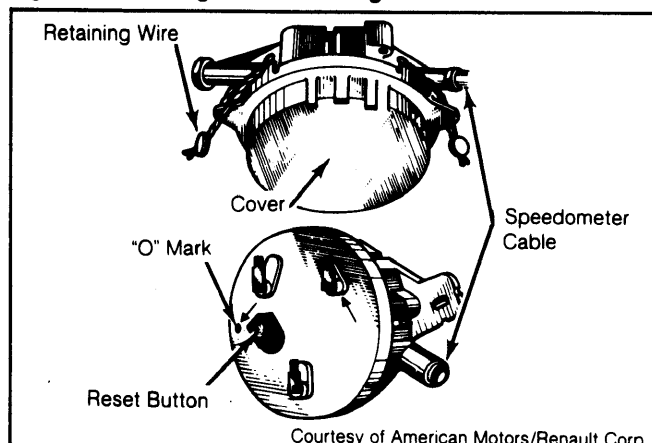

SUBARU

EGR WARNING LIGHT

1) On 1985-87 models with 1.8L engine, an EGR system light will turn on.

2) To reset EGR light (after servicing EGR system), remove left cover under instrument panel. Pull down connectors behind fuse panel. Remove connector from Blue connector and connect to Green connector.

SUZUKI

OXYGEN SENSOR WARNING LIGHT

1) On Samurai models, a "SENSOR" light will start flashing every 60,000 miles. The light flashing will only occur with a warm engine at 1500-2000 RPM. This indicates the ECM is in good condition and the oxygen sensor needs replacement.

2) When all emission system service procedures have been completed, locate "SENSOR" light cancel switch attached to steering column bracket. Turn cancel

Maintenance Reminder Light

1980-88 RESET PROCEDURES IMPORTED CARS & TRUCKS (Cont.)

switch to opposite position. Start engine to ensure light does not flash.

TOYOTA

TIMING BELT WARNING LIGHT DIESEL PICKUP

On Diesel Pickups, maintenance reminder light will come on every 50,000 miles (60,000 on 1982-83 models). The engine timing belt should be replaced at this time. After belt is replaced, remove rubber grommet from speedometer bezel and reset speedometer counter by pressing reset switch.

**Fig. 13: Resetting Speedometer Counter
On Toyota Diesel Pickups**

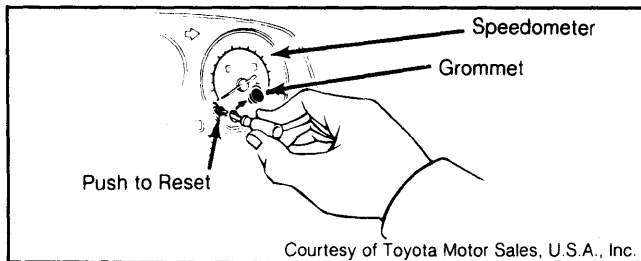

Courtesy of Toyota Motor Sales, U.S.A., Inc.

OXYGEN SENSOR WARNING LIGHT

1) All 1980 Celica (6-cylinder), Supra and Cressida models and all 1981 models with gasoline engines (except Starlet) are equipped with an oxygen sensor. At 30,000 mile intervals, a mileage counter activates a warning light in the dash. The oxygen sensor must be inspected at this time.

2) On vehicles with High Altitude Compensation (HAC), disconnect vacuum hose between HAC valve and check valve. Plug check valve. On vehicles with a Vacuum Control Valve (VCV), disconnect the lower vacuum line (from VCV to vacuum connector) and plug connector.

3) Warm engine to normal operating temperature. Locate service connector on left fender, near ignition coil. Remove rubber cap and connect a voltmeter to connector with positive probe at "Ox" terminal and negative probe at "E" terminal.

4) Run engine at 2500 RPM for 90 seconds. Maintain engine speed and check needle on voltmeter. It should fluctuate between zero and 7 volts at least 8 times in a 10 second period. If not, check all hose connections and wiring. If no other fault is found, replace oxygen sensor.

5) To reset warning light, remove cancel switch (White) from top of left kick panel, except on Cressida and 1980 Celica Supra. Remove small panel next to steering column on Cressida models. On 1980 Celica Supra, switch (Black) is located on bracket above brake pedal. Open switch cover and move switch to the opposite position.

Fig. 14: Testing Toyota Oxygen Sensor

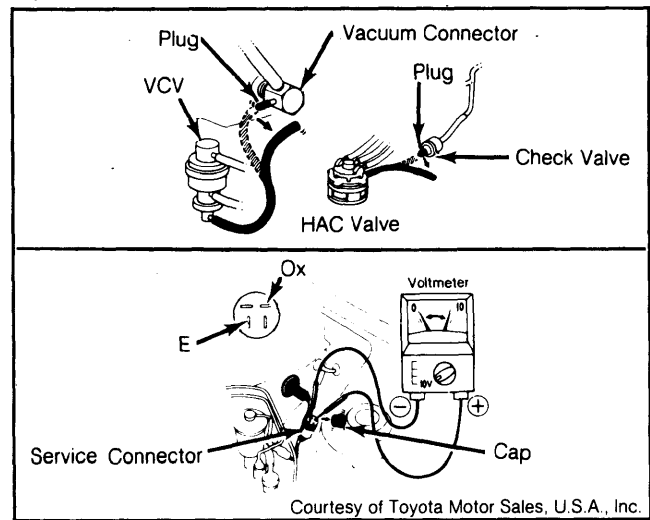

Courtesy of Toyota Motor Sales, U.S.A., Inc.

TRIUMPH

OXYGEN SENSOR WARNING LIGHT

1) All fuel-injected Triumphs are equipped with an oxygen sensor. When the warning light on the dash comes on (at 30,000 mile intervals), replace the sensor.

2) After replacing sensor, locate the interval counter (in-line with speedometer cable). Reset counter using Key (BLT-5007) supplied in kit with new sensor.

VOLKSWAGEN

EGR MAINTENANCE LIGHT

Check EGR system operation every 15,000 miles ("EGR" light will come on). After system check, reset mileage counter.

OXYGEN SENSOR WARNING LIGHT

Replace oxygen sensor when "OXS" light comes on (30,000 miles). With new sensor installed, reset the mileage counter.

RESETTING MILEAGE COUNTER

1) On some Rabbit and Pickup models, remove instrument panel cover plate. Reach into opening at top left corner of speedometer and pull release arm to reset counter. Left arm resets EGR, right arm resets oxygen sensor.

2) On Vanagon models, locate mileage counter (under spare tire or under driver's floorboard, in-line with speedometer cable). Using a pointed instrument, depress raised area on reset box. Ensure light is out.

3) On all other models, locate mileage counter (in-line with speedometer cable) and push White reset button. Ensure maintenance light is out.

Maintenance Reminder Light

1980-88 RESET PROCEDURES IMPORTED CARS & TRUCKS (Cont.)

Fig. 15: Resetting Volkswagen Mileage Counters

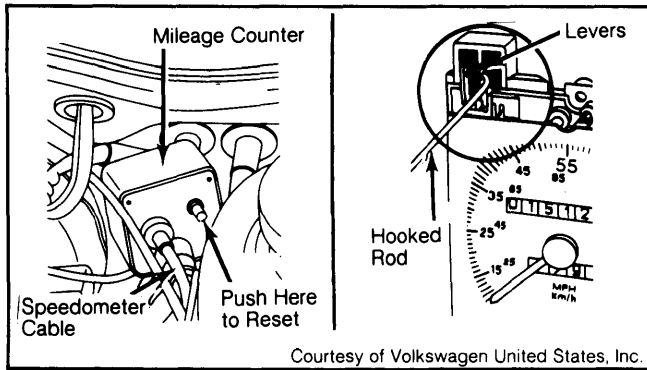
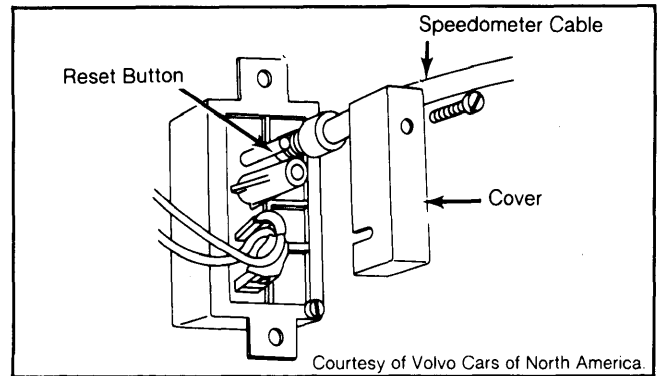

Fig. 16: Resetting Volvo Mileage Counter



VOLVO

OXYGEN SENSOR WARNING LIGHT

1) On 1980-85 models (and 1986 760 GLE models) equipped with an oxygen sensor system, a warning light in the dash will illuminate every 30,000 miles as a reminder to replace the sensor.

2) To reset warning light (after replacing sensor) on 1980-84 models, locate the mileage counter in-line with the speedometer cable. On 1985 models and 1986 760 GLE models, locate unit under dash (follow wires or small cable from back of speedometer to unit). Remove retaining screw and switch cover. Press reset button. Ensure reminder light is out. Replace switch cover.

3) On 1986 models (except 760 GLE) and 1987-88 models there is no warning light used for O₂ sensor service intervals.

SERVICE INTERVAL REMINDER LIGHT

1) On 1987-88 Volvos, an oil service interval reminder light will come on at 5000 mile intervals. This light will illuminate for 2 minutes after each ignition cycle, until counter is reset.

2) To reset counter, locate button behind right center of instrument cluster and press.

Fig. 17: Resetting Volvo Service Interval Light

