

MITSUBISHI ELECTRONIC IGNITION SYSTEM

Arrow	Colt Wagon
All 2600 cc	Courier
Calif. 1600 cc	Mazda
Arrow Pickup	GLC
Champ & Colt Hatchback	626
Calif. Only	B2000 Pickup
Challenger	Sapporo

DESCRIPTION

Mitsubishi transistorized breakerless ignition consists of an electronic control module (ignitor), ignition coil and distributor. On some models, the control module was mounted with the ignition coil on the left fender apron. See Fig. 1. On others, such as Chrysler Corp., Courier 2000 cc, and Mazda 626 and B2000 Pickup, the control module was mounted on the outside of the distributor housing. See Fig. 2.

The GLC utilizes a dual timing ignition system to control spark timing. The system consists of two water thermo switches and a timer unit. See Fig. 8. Within a 2 minute period after starting the engine, timing is retarded when the coolant temperature range is 50-122° F (10-50° C). Advance timing is 5° BTDC; retard timing is 1° BTDC. As the engine warms to normal operating temperature, timing will advance to 5° BTDC.

The Mazda 626 utilizes a water thermo valve to cut advance when the engine is cold. Federal B2000 Pickups use a vacuum delay valve during acceleration, and Calif. B2000 Pickups use both a water thermo valve and vacuum delay valve. On Calif.

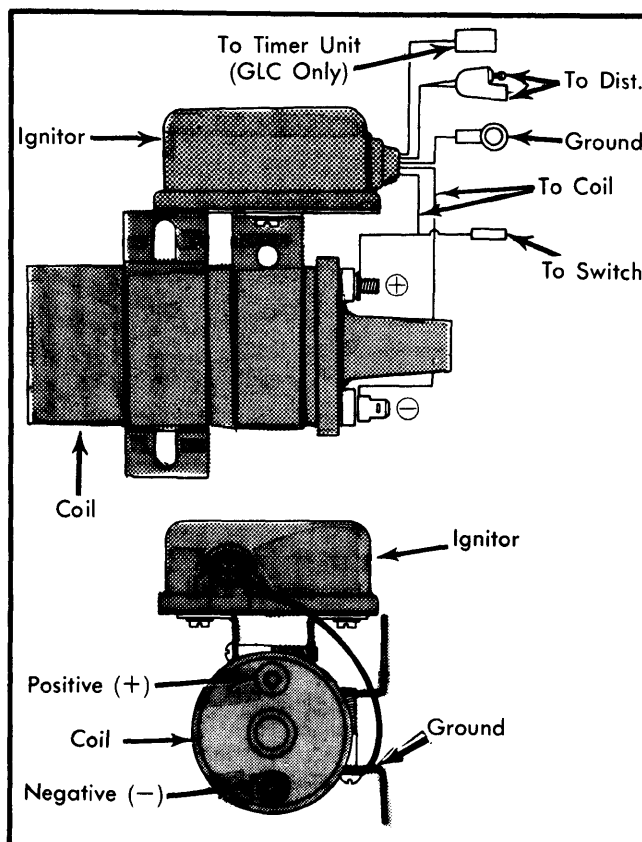

Fig. 1 Control Module & Coil Wiring Connections (GLC & Courier 2300 cc)

models, vacuum advance is cut when engine is cold and delayed during acceleration.

OPERATION

Whenever the ignition switch is "ON", the primary circuit of the ignition coil is energized. As the distributor shaft rotates, the armature (reluctor) rotates inside the magnetic pick-up coil (stator) assembly. See Fig. 2. As the teeth of the armature pass the pegs of the pick-up coil and breaker plate assembly, a signal is sent to the control module (ignitor). The module then breaks the primary circuit in the coil, inducing high voltage in the secondary circuit firing the spark plugs.

SPECIFICATIONS

Centrifugal & Vacuum Advance — See Specifications Pages in this section.

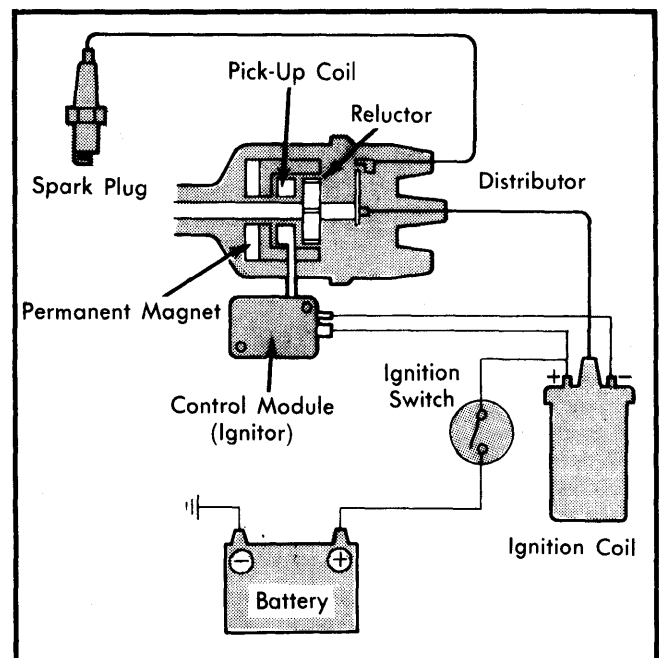

Fig. 2 Wiring Schematic of Mitsubishi Transistorized Breakerless Ignition System (Chrysler Corp., Courier 2000 cc, Mazda 626 & B2000 Pickup)

ADJUSTMENTS

NOTE — There is no air gap adjustment possible on Chrysler Corp. Imports, Mazda B2000 Pickup & 626, or Courier 2000 cc engines.

Armature-to-Pick-Up Coil Air Gap — Align teeth of armature (reluctor) with pegs of pick-up coil and breaker plate assembly. Using a feeler gauge, check for air gap of .008-.024" (.2-.6 mm) on Courier 2300 cc engine or .010-.014" (.25-.35 mm) on GLC. To adjust gap, loosen set screws and move pick-up coil.

NOTE — No other adjustments should be attempted on the ignition system except armature-to-pick-up coil air gap, spark plug gap and initial ignition timing.

Distributors & Ignition Systems

MITSUBISHI ELECTRONIC IGNITION SYSTEM (Cont.)

TESTING

NOTE — Be sure battery is at full charge and in good condition before making any tests. Check all wiring harnesses, ignition switch, coil and spark plug cables and connectors.

HIGH VOLTAGE TEST

Chrysler Corp., Courier 2000 cc, & Mazda B2000 Pickup & 626 — Remove distributor cap and remove rotor assembly. Turn ignition switch "ON". Disconnect coil wire from distributor cap and hold its end 1/4" (6 mm) from cylinder block. Insert a conventional screwdriver blade between the armature (reluctor) and magnetic pick-up coil. See Fig. 3. If no spark is produced at gap, suspect a defective control unit, pick-up coil assembly, ignition coil or secondary cables.

Other Models — Connect a remote starter switch in the starting circuit and remove coil wire from distributor cap. Turn ignition switch "ON" and hold coil wire 1/4" (6 mm) from cylinder block. Crank engine. If no spark or a weak spark results, perform the following tests.

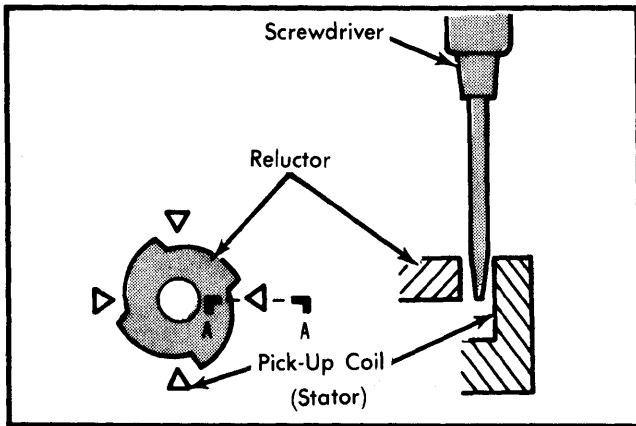

Fig. 3 High Voltage Test with Screwdriver (Chrysler Corp., Mazda B2000 Pickup & 626, Courier 2000 cc)

IGNITION COIL RESISTANCE TEST

1) Turn ignition switch "OFF". Set an ohmmeter in the low scale and attach its leads to the coil positive and negative terminals. Coil should be isolated from rest of system. Check primary resistance reading. Replace coil if not to specifications. See Fig. 4.

2) Set ohmmeter in x1000 scale and attach leads to positive primary terminal and secondary tower. Check secondary resistance reading. Replace coil if not to specifications.

Ignition Coil Resistance Specifications (Ohms)

Application	Primary	Secondary
Chrysler Corp.70-.85	9,000-11,000
Courier81-.99	6,800-9,200
Mazda GLC	1.28	13,500
Mazda 626 & B200081-.99	7,000

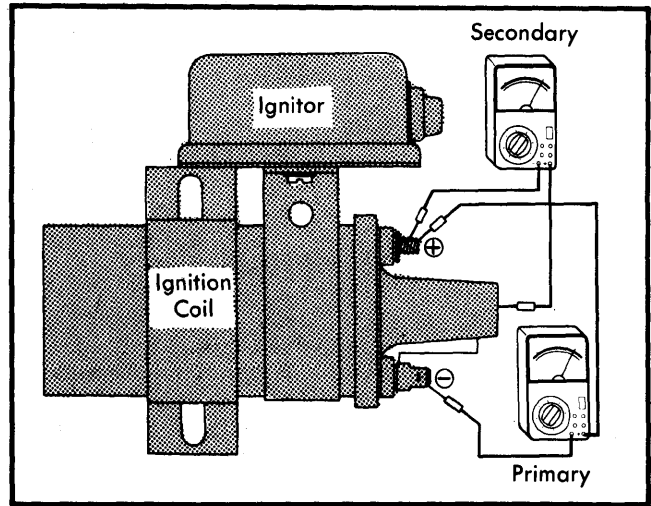

Fig. 4 Ohmmeter Hookup for Ignition Coil Primary & Secondary Resistance Test

MAGNETIC PICK-UP COIL RESISTANCE TEST

Turn ignition switch "OFF". Set an ohmmeter in the x100 scale. Attach its leads to pick-up coil's distributor connector terminals. Resistance reading for Chrysler Corp., Courier 2000 cc, and Mazda B2000 Pickup & 626 should be 1,000-1,100 ohms. Courier 2300 cc resistance should read 760-840 ohms; Mazda GLC, 670-790 ohms. If not to specifications, replace pick-up coil assembly.

NOTE — On Chrysler Corp., Mazda B2000 Pickup & 626, and Courier 2000 cc engines, connect ohmmeter leads as shown in Fig. 5. On other models, connect leads to distributor connector terminals.

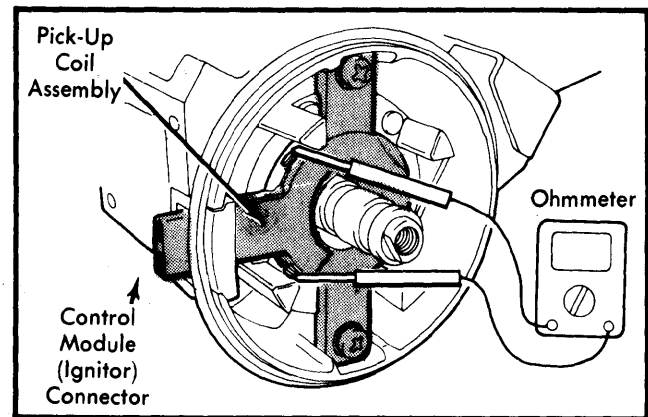

Fig. 5 Ohmmeter Hookup for Pick-Up Coil Resistance Test (Chrysler Corp., Courier 2000 cc and Mazda 626 & B2000 Pickup)

IGNITION MODULE TEST

Courier (2300 cc) — 1) Connect a test light (3.4 watts) to the ignition coil positive and negative terminals. See Fig. 6. Attach one end of a jumper wire to the positive terminal of the ignition coil. Disconnect the 2-pin distributor connector.

2) Attach other end of jumper wire to the red wire terminal on the module side of the connector. Turn the ignition switch

MITSUBISHI ELECTRONIC IGNITION SYSTEM (Cont.)

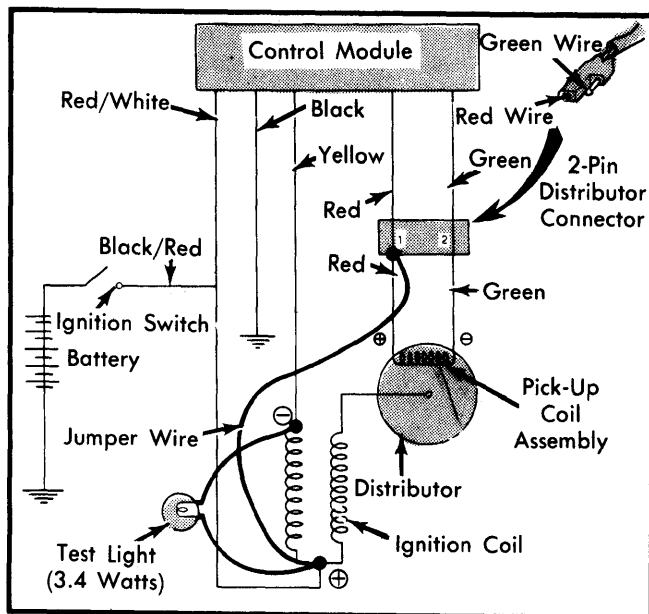

Fig. 6 Courier Ignition Control Module Test (2300 cc engine)

"ON". The test light should come on. The light should go out when the jumper wire is disconnected.

3) If test light does not function as stated, retest to make sure bulb is OK and that all connections are tight. If results are still improper, replace control module and retest.

Chrysler Corp., Courier 2000 cc, and Mazda B2000 Pickup and 626 - 1) Turn ignition switch "OFF". Using an ohmmeter, check for continuity between terminal "C" of the control module (ignitor) and its metallic reverse surface. See Fig. 7. If the module is installed on the distributor, make check between terminal "C" and distributor housing (ground).

2) Perform test in same manner as a diode test, alternately switching the leads of the ohmmeter. If there is continuity or if there is an open circuit in both directions, the control module is defective and must be replaced.

NOTE - Only the transistors in the switching section of the control module are evaluated by this test. The module may still

be defective, even if the test shows good. If control module checks OK, but system does not operate properly, substitute a known good module and attempt to start vehicle.

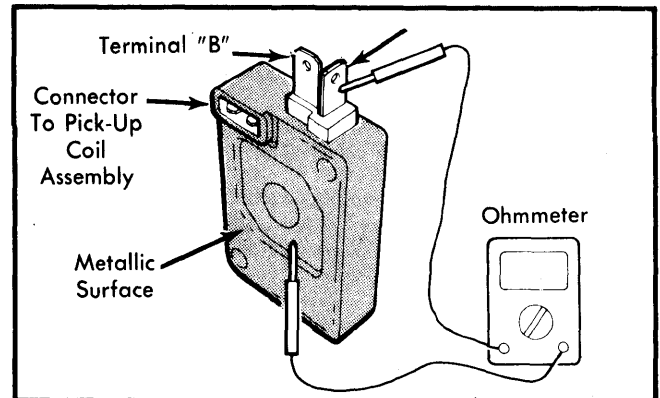

Fig. 7 Checking Transistors in Switching Section of Control Module/Ignitor (Chrysler Corp., Courier 2000 cc, Mazda B2000 Pickup and 626)

SECONDARY WIRE RESISTANCE TEST

Test coil and spark plug cables with an ohmmeter. Do not puncture secondary wires when making the resistance check. Connect leads to each end of the cable. Resistance for Courier should not exceed 570 ohms per inch; for Mazda vehicles, resistance should not exceed 16,000 ohms for each 39" (1 m); and Chrysler Corp. vehicles should not exceed 22,000 ohms per cable.

TIMER TEST (GLC ONLY)

1) To check timer (located under instrument panel on left side panel), connect wires to terminals "A", "B", and "C" of timer. See Fig. 8. Connect a wire with a 30,000 ohm resistor to terminal "D". Connect a wire with a 3.4 watt test lamp to terminal "E". Connect a voltmeter to terminal "D" and to negative battery terminal.

2) Connect wires from terminals "A", "D", and "E" to battery positive terminal. Connect wire from terminal "C" to battery negative terminal. Voltmeter should show more than 6 volts.

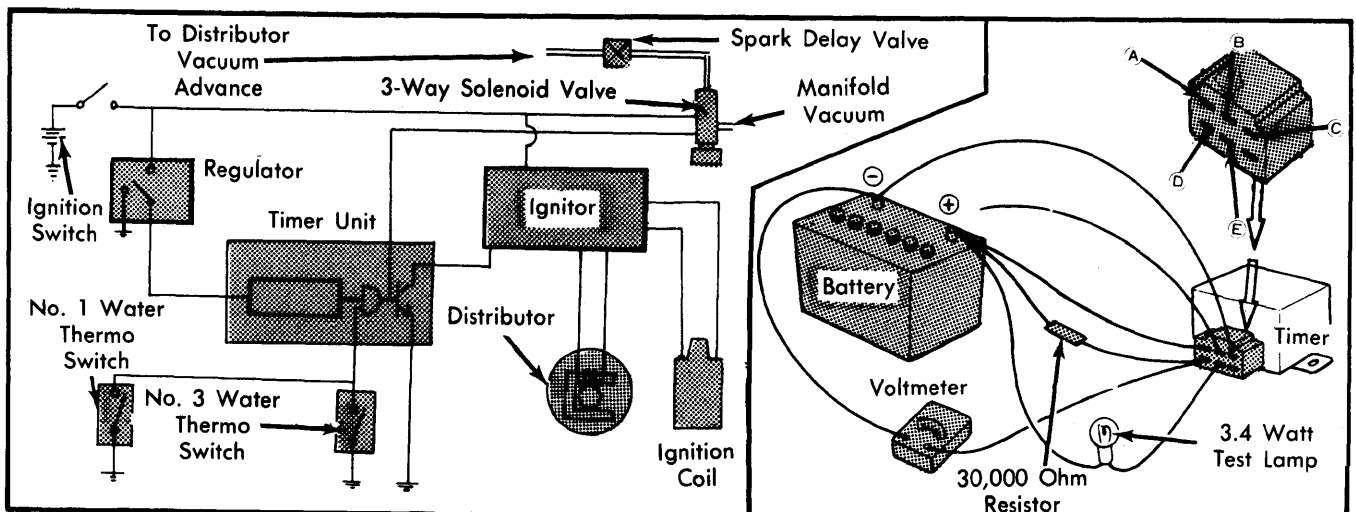

Fig. 8 Schematic of GLC Dual Timing System and Voltmeter Hookup for Timer Test

Distributors & Ignition Systems

MITSUBISHI ELECTRONIC IGNITION SYSTEM (Cont.)

3) Then, connect wire from terminal "B" to battery positive terminal. Instantly, voltmeter should show less than 1 volt and test lamp should light. After approximately 105-135 seconds from showing 1 volt, voltmeter should indicate 8 volts. If not, replace timer.

OVERHAUL

**CHRYSLER CORP., COURIER 2000 cc
MAZDA B2000 PICKUP AND 626**

Disassembly - 1) To remove control module (ignitor) from distributor housing, remove 2 screws and pull straight outward on module to unplug it from pick-up coil assembly. See Figs. 9 and 10.

NOTE - Do not remove the silicone grease from either mating surface of the module or distributor housing.

2) Remove distributor cap by inserting screwdriver in screw heads, depressing and turning retaining lugs. Remove rotor assembly, governor assembly with reluctor and then remove pick-up coil assembly.

3) Remove vacuum control unit screws and "E" ring from vacuum link. Lift out vacuum control unit. Remove breaker plate assembly, spring pin securing driven gear and remove plate and shaft from housing.

Reassembly - Reverse removal procedure. Inspect cap and rotor for cracks and deposits on inside surfaces. Check driven gear for wear and shaft for play in thrust direction.

**COURIER 2300 cc
AND MAZDA GLC**

Disassembly - 1) Remove distributor cap and rotor. See Fig. 7 and 8. Remove cover, gasket and grommet. Remove clips.

Drive roll pin from armature (reluctor) and remove armature. Remove clip holding vacuum diaphragm link. Remove vacuum control unit.

2) Remove pick-up coil assembly. Drive lock pin from driven gear and remove gear. Remove governor and shaft assembly from distributor housing.

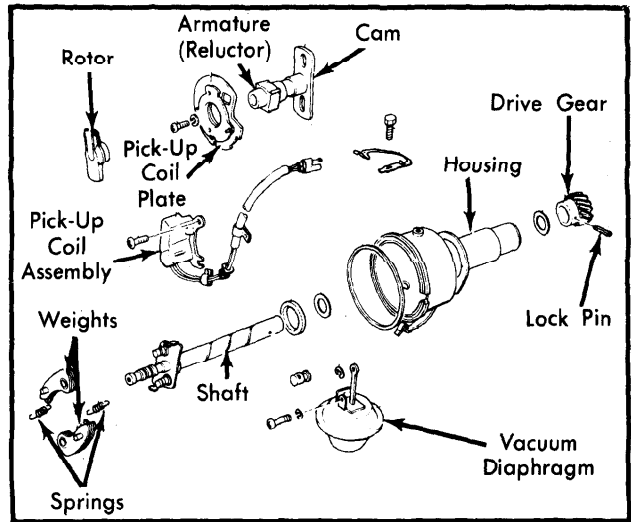
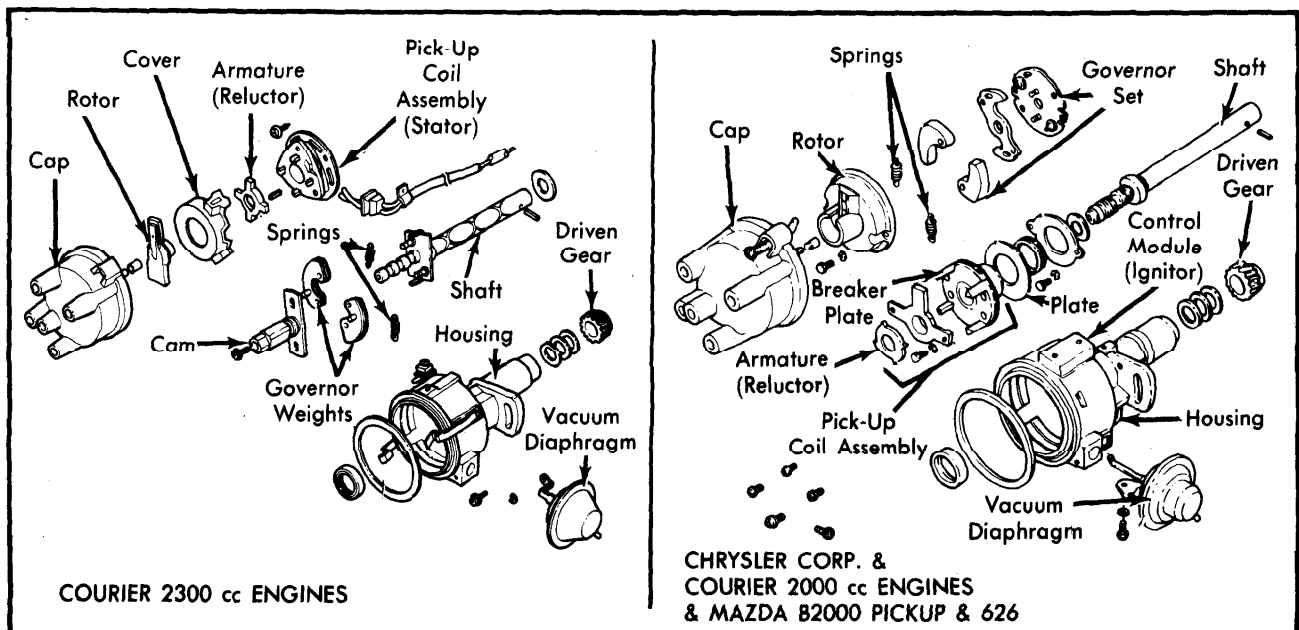

Fig. 10 Disassembled View of Distributor (Mazda GLC)

Reassembly - Reverse disassembly procedure. When installing cam, align marks on distributor housing and gear. Align rotor metal end with clip mounting lug on side of distributor with mounting slot.



COURIER 2300 cc ENGINES

**CHRYSLER CORP. &
COURIER 2000 cc ENGINES
& MAZDA B2000 PICKUP & 626**

Fig. 9 Disassembled View of Courier, Mazda (Except GLC) & Chrysler Corp. Distributors