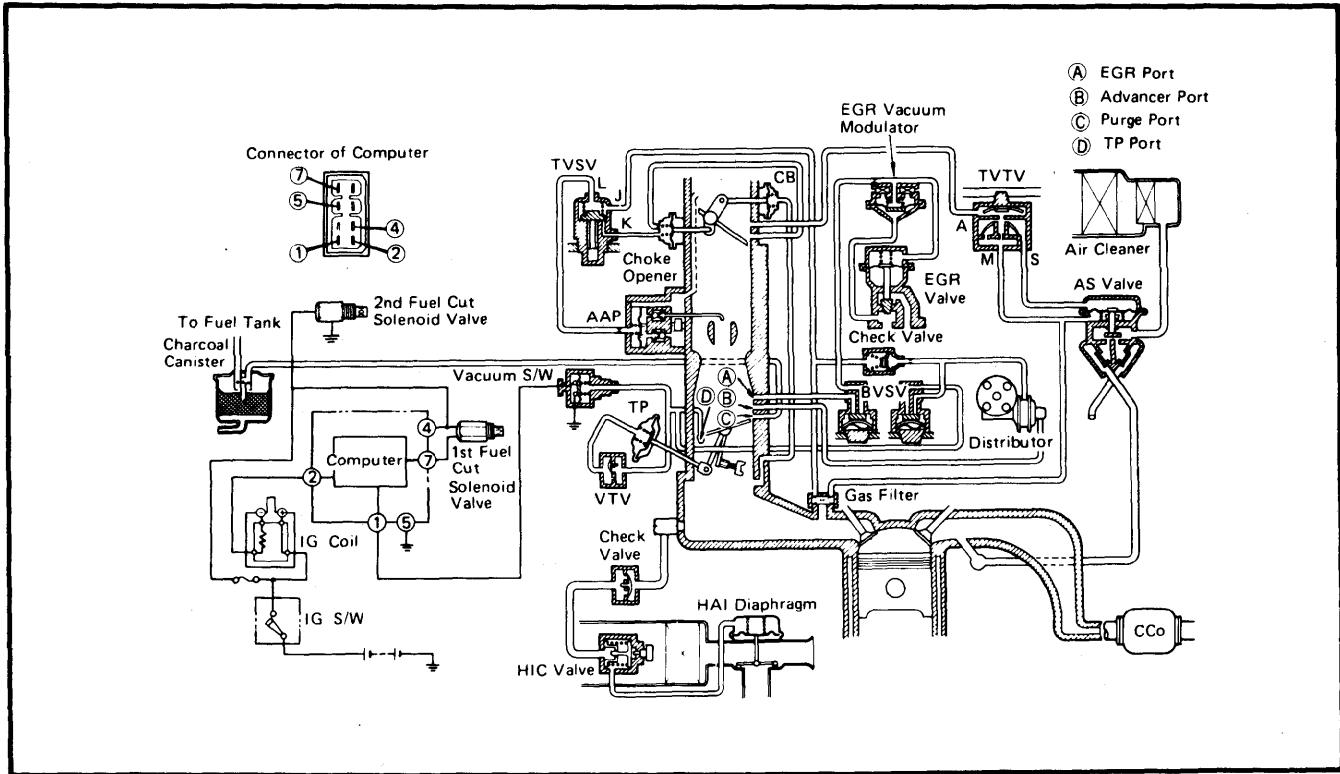
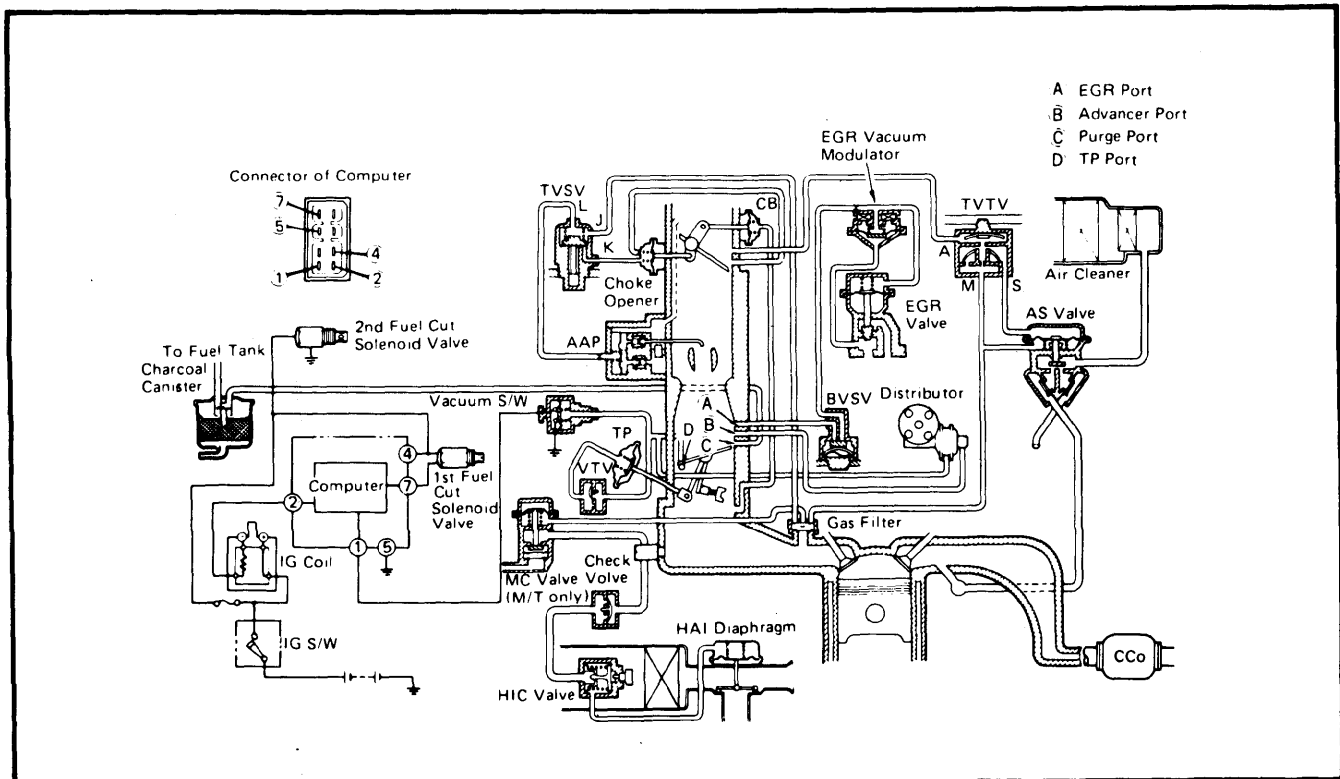


# 1980 Exhaust Emission Systems

## TOYOTA VACUUM DIAGRAMS

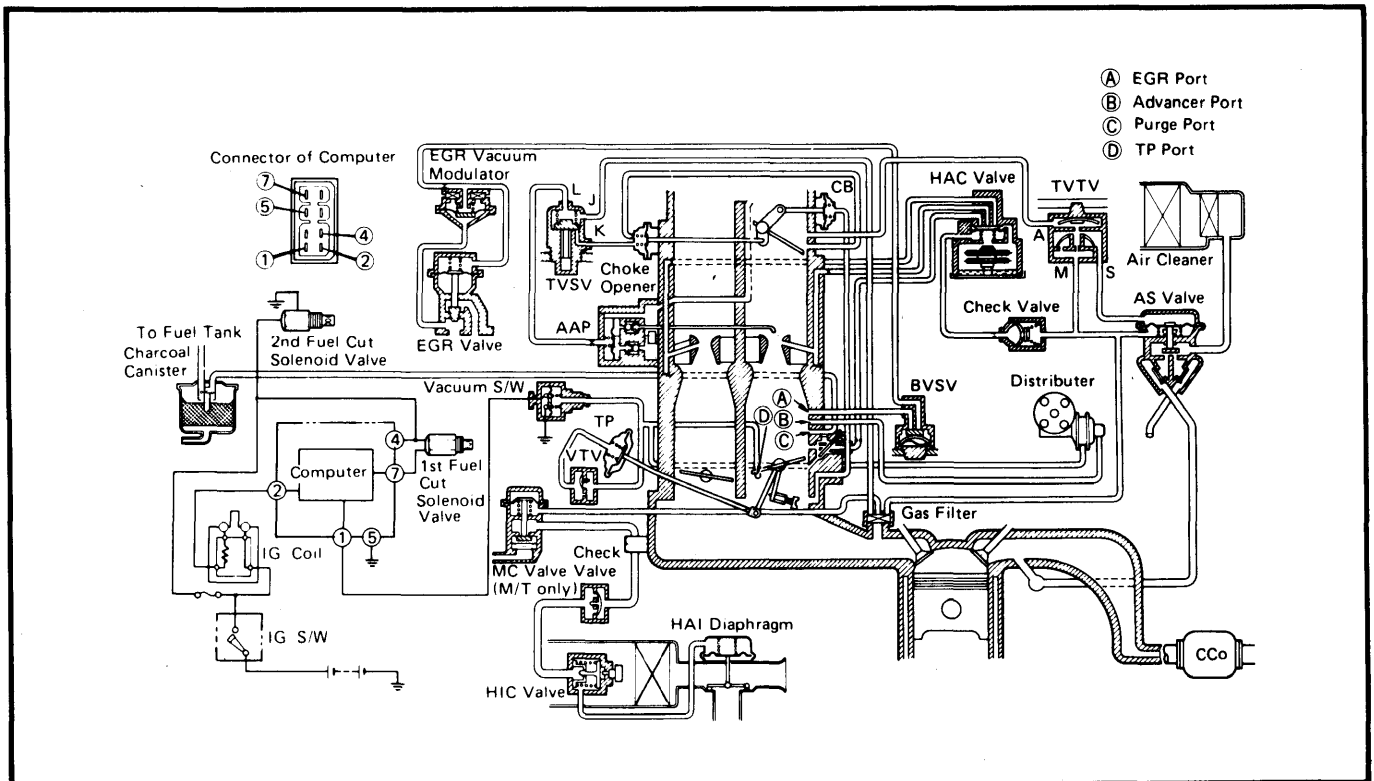


**Fig. 1 Toyota Corolla (Federal W/O Cold Advance & High Altitude Compensation)**

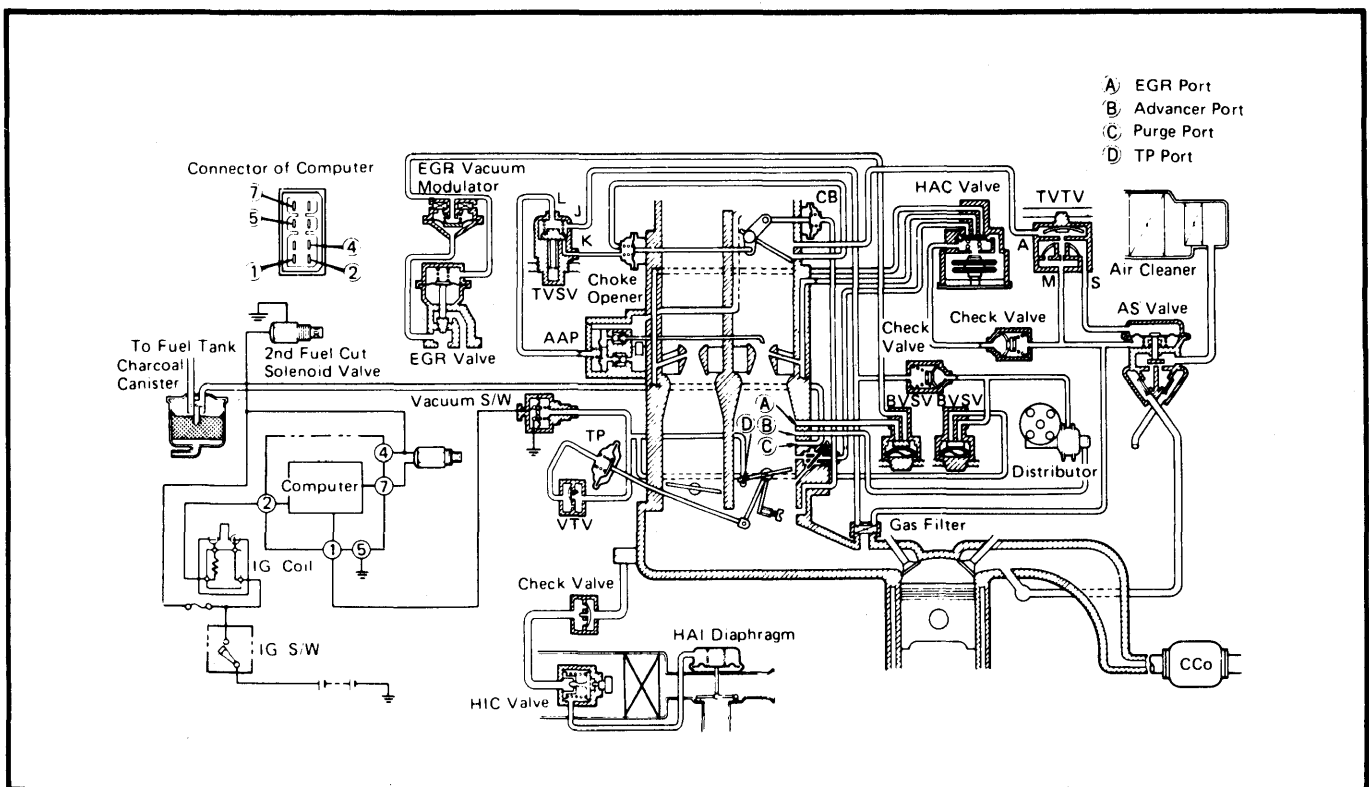


**Fig. 2 Toyota Corolla (Federal with Cold Advance System)**

## TOYOTA VACUUM DIAGRAMS (Cont.)



**Fig. 3 Toyota Corolla (Federal with High Altitude Compensation)**



**Fig. 4 Toyota Corolla (Federal with Cold Advance and High Altitude Compensation)**

# 1980 Exhaust Emission Systems

## TOYOTA VACUUM DIAGRAMS (Cont.)

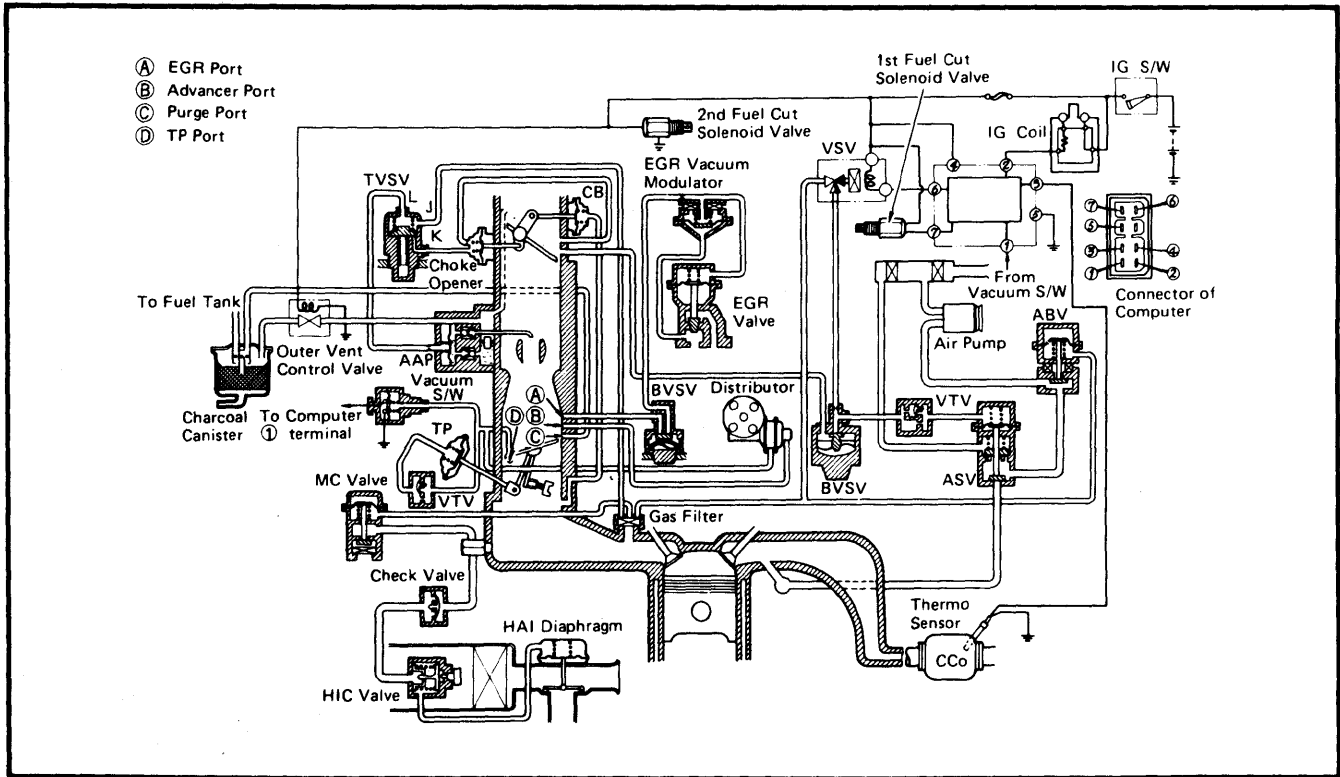


Fig. 5 Toyota Corolla (California)

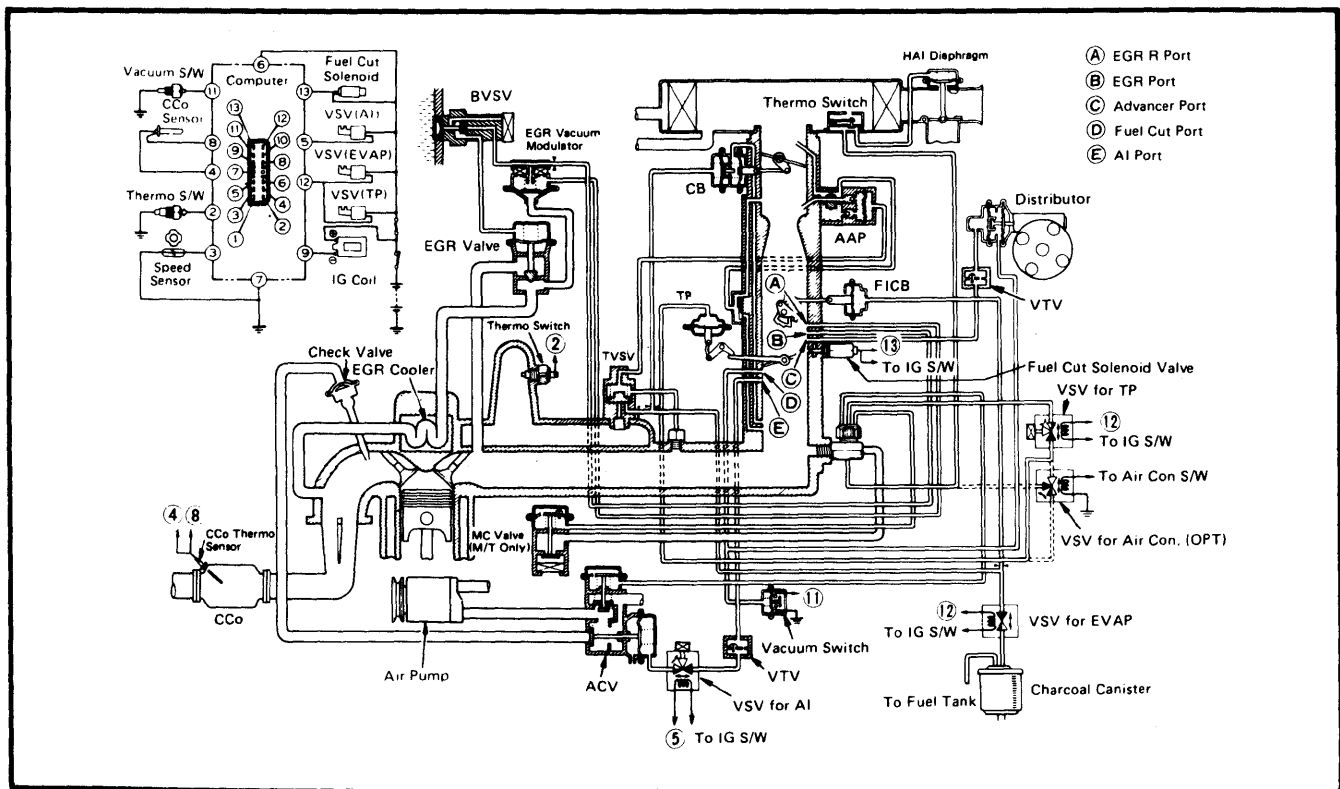
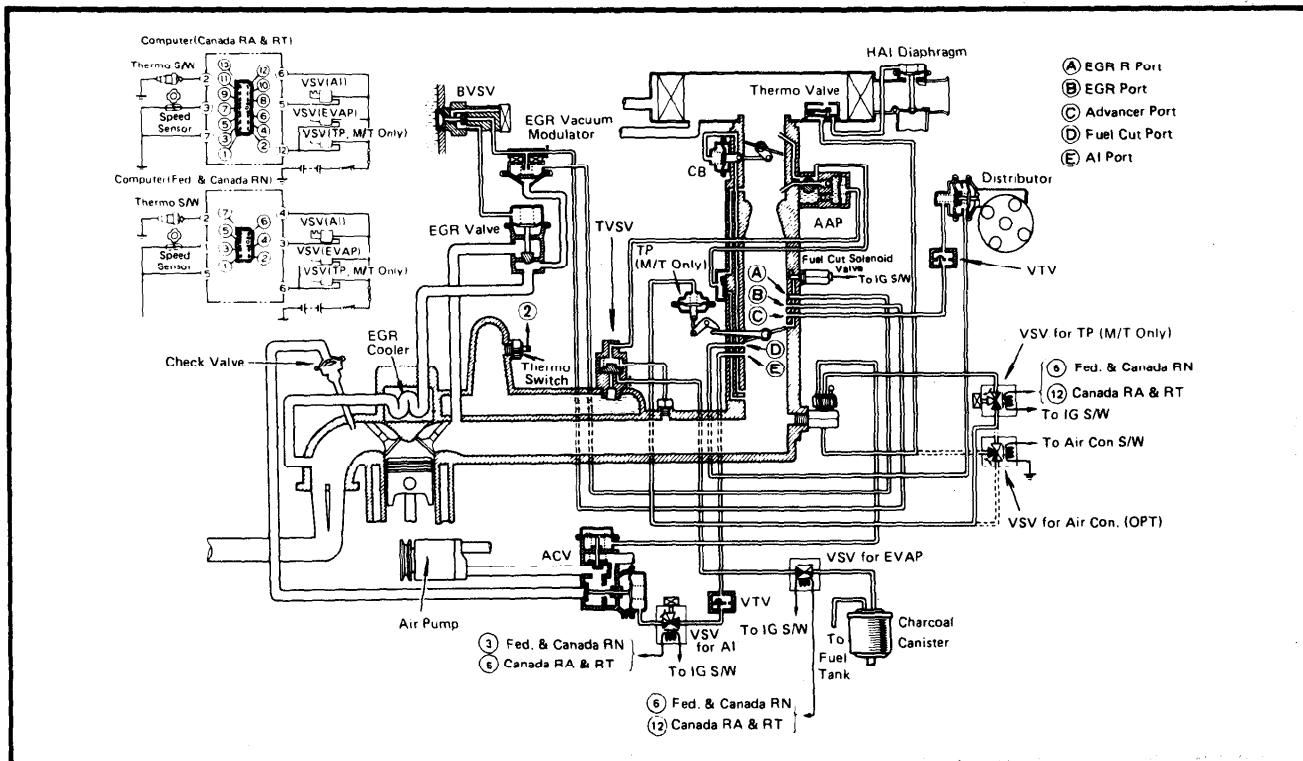
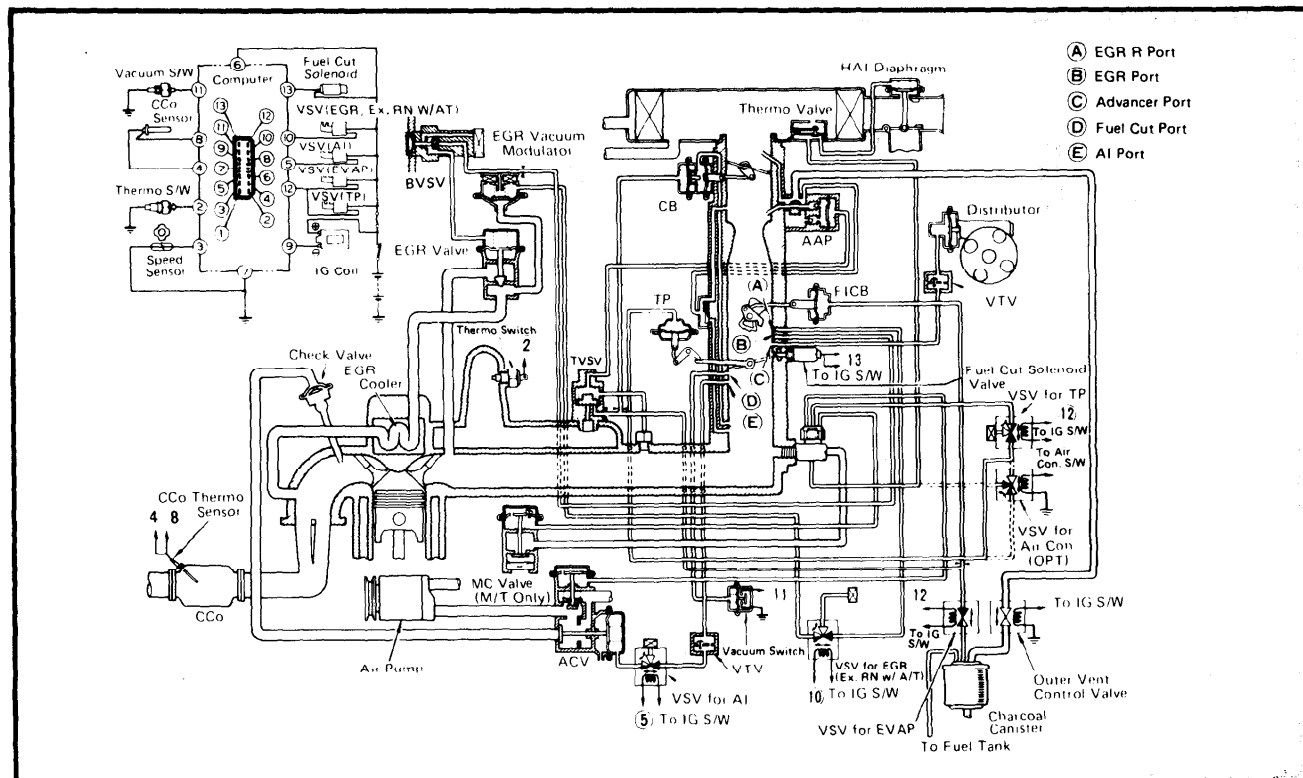


Fig. 6 Toyota Celica and Corona (Federal)

## TOYOTA VACUUM DIAGRAMS (Cont.)



**Fig. 7 Toyota Pickup (Federal)**



**Fig. 8 Toyota Celica, Corona and Pickup (California)**



## TOYOTA VACUUM DIAGRAMS (Cont.)

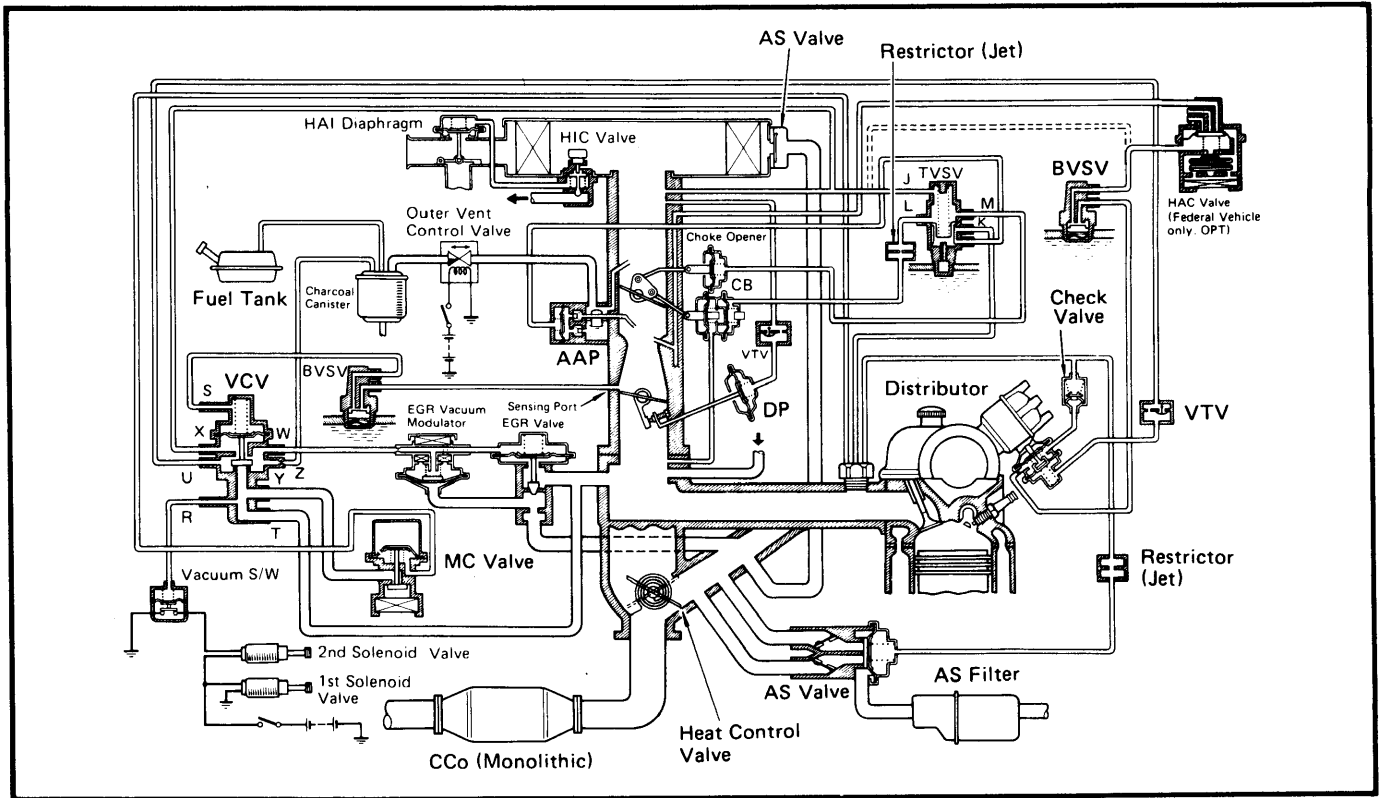


Fig. 11 Toyota Tercel

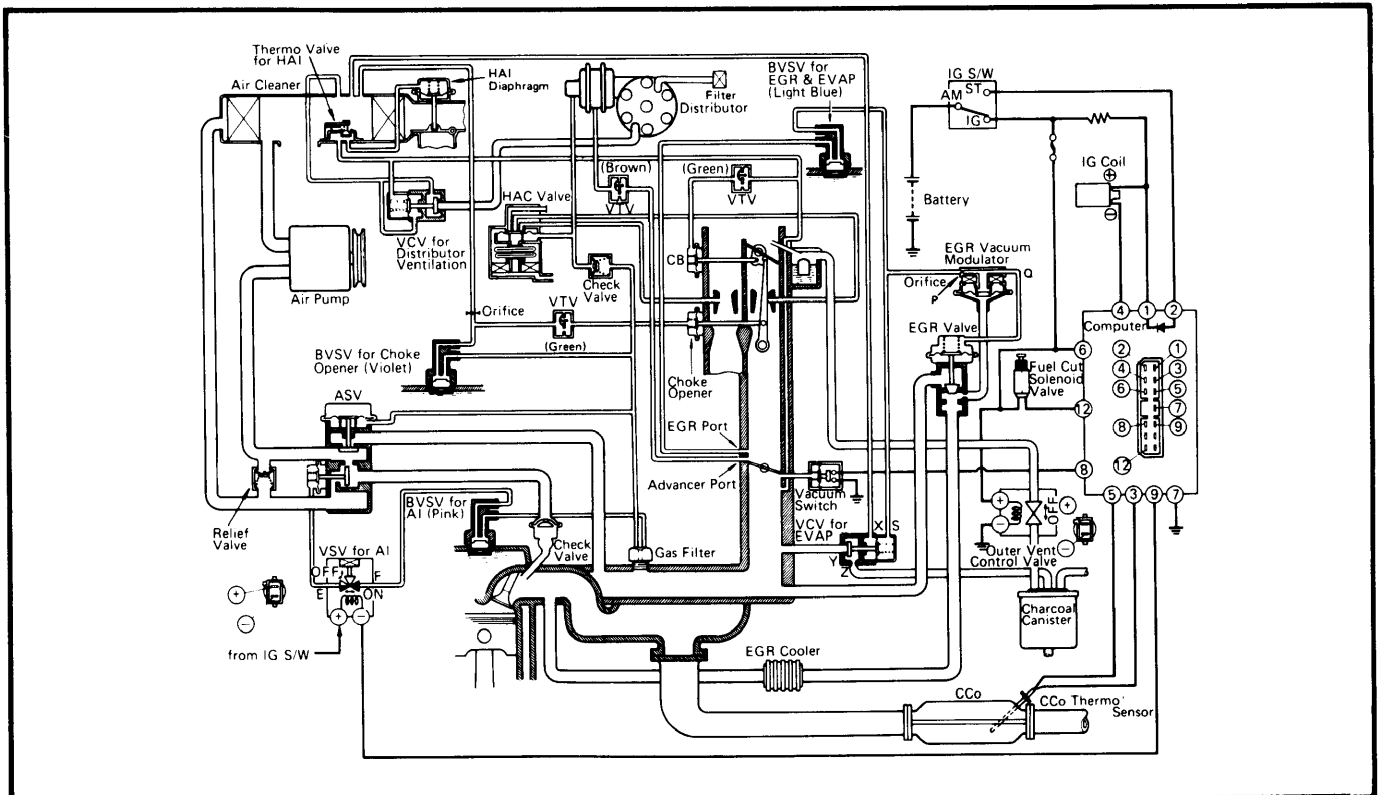
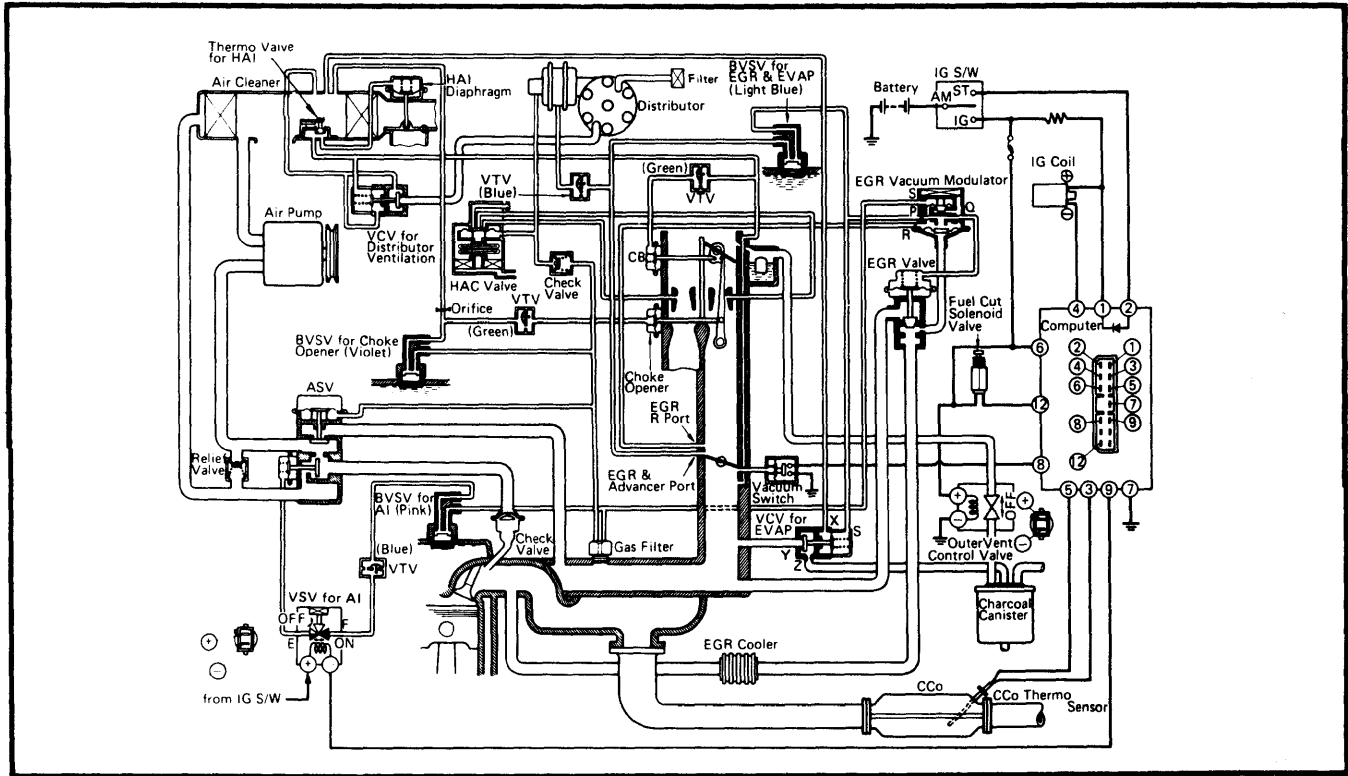


Fig. 12 Toyota Land Cruiser (Federal)

# 1980 Exhaust Emission Systems

## TOYOTA VACUUM DIAGRAMS (Cont.)



**Fig. 13 Toyota Land Cruiser (California)**