

RENAULT FAST IDLE DECELERATION SYSTEM

Le Car

DESCRIPTION

The fast idle system is designed to reduce HC emissions which result from the throttle closing on deceleration, creating an over-rich mixture. On Federal vehicles, the system consists of a throttle plate opener and a delay valve. California models use those components plus a vacuum reservoir, check valve, vacuum regulator, solenoid valve and electronic speed sensor.

OPERATION

Federal – When deceleration starts, the high vacuum present at throttle opener port passes through delay valve and holds throttle plate opener so additional air passes through carburetor. The delay valve ensures an automatic, slow return to idle as it vents the vacuum to atmosphere through an orifice.

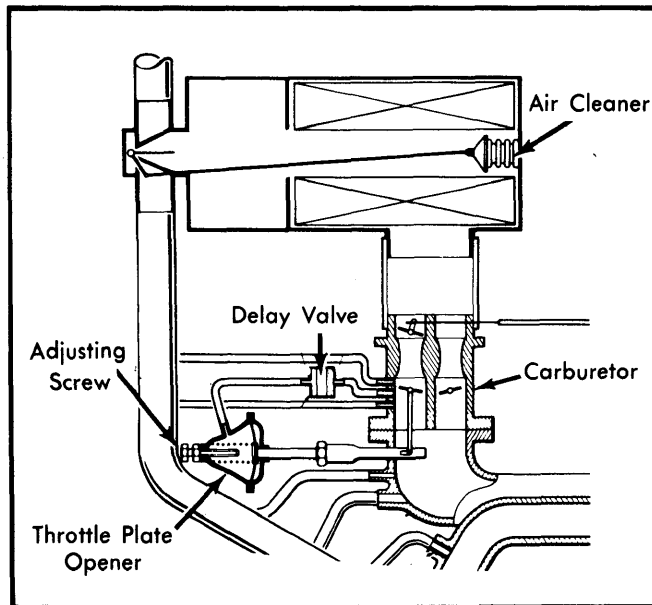

Fig. 1 Federal Le Car Fast Idle System

California – One circuit of system pulls vacuum at throttle opener port, the other at intake manifold. When the throttle plate closes, creating more than 10.6 in. (270 mm) Hg, the check valve closes and the throttle plate opener is pulled open. Vacuum drops slowly as it is bled off by the delay valve.

When vacuum drops too low, the check valve opens. Intake manifold vacuum is applied and controlled by vacuum regulator at 6 in. (150 mm) Hg. This vacuum keeps the throttle plate positioner half-open. When vehicle speed drops below 17 mph, the speed sensor turns off the solenoid valve. Manifold vacuum is cut off and the throttle closes.

A separate dashpot (not vacuum controlled) keeps the throttle from closing completely for 2-4 seconds.

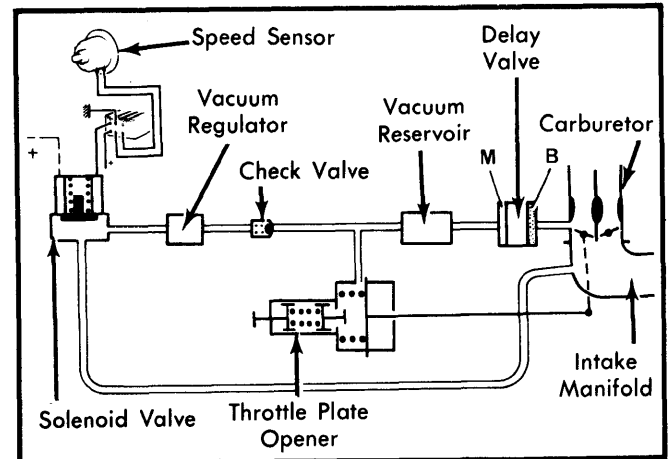

Fig. 2 Calif. Le Car Fast Idle System

TESTING

Federal – Connect intake manifold vacuum directly to throttle plate opener. Engine speed should stabilize at 1800-2000 RPM. Reconnect vacuum hose, accelerate engine to 2500 RPM and release throttle slowly. Engine speed should slowly drop (3-5 seconds).

California – Accelerate engine to 4000 RPM and release throttle. Engine speed should return to idle between 3-6 seconds. Drive at speed over 21 MPH, then depress clutch. Engine speed should stabilize at 1400-1600 RPM as long as vehicle remains above 17 MPH.

ADJUSTING

Federal – Using a hand vacuum pump, apply at least 4.5 in. (110 mm) Hg vacuum to throttle plate opener. Adjust screw on top of diaphragm to give idle speed of 1800-2000 RPM.

California – Ground fast idle solenoid (green) wire, or apply less than 6 in. (150 mm) Hg vacuum to throttle plate opener. Adjust idle speed with screw on opener to 1400-1600 RPM.